

Owner's Manual with Installation Instructions

Banks Ram-Air[®] Intake System

**2003-2007 (235, 250, 305 and 325 HP)
Dodge 5.9L Cummins (24-valve)
ISB Pickup Trucks**

THIS MANUAL IS FOR USE WITH KIT 42145

Gale Banks Engineering
546 Duggan Avenue • Azusa, CA 91702
(626) 969-9600 • Fax (626) 334-1743

Product Information & Sales: (888) 635-4565

bankspower.com

Also Available from Banks Power

03-07 Dodge 5.9L



Banks iQ System (P/N 61148-61149)

- 5" touchscreen interface that can control the Banks Diesel Tuner on the fly.
- Interchangeable gauge display, read and clear codes, monitor engine diagnostics, log data, time your vehicles runs and much more.

Banks Monster® Exhaust System Single (P/N 48640-48643, 48700, 48701, 48708)

Duals (P/N 48702-48707, 48709) Sport (P/N 48777-48780)

- Increases exhaust flow, cuts backpressure, lowers exhaust gas temperatures (EGTs) and increases power

Banks Ram-Air Intake Super-Scoop (P/N 42190-42191)

- Adds cooler denser air to the Ram-Air Intake housing, further increasing fuel economy, reducing smoke and lowers EGTs.

Banks Monster-Ram (P/N 42765-42766)

- Increased flow from intercooler
- Raises boost without increasing backpressure at the turbine

Big Hoss Intake Manifold System (P/N 42747)

- Increases flow and provides more uniform air distribution to the engine for more available power at a given boost level.

Banks Techni-Cooler® System (P/N 25980-25981)

- Provides increased air flow to the engine by increasing air density for more increased power, lower EGTs and improved fuel economy.

Banks Exhaust Brake (P/N 55222-55229)

- Increases the stopping power of your truck and extends the service life of your brakes

Banks SmartLock
(P/N 55270)

- Reduces wear on transmission
- Locks Torque Converter and raises trans-line pressure
- Works with Banks Exhaust Brake

Banks Billet Torque Converter
(P/N 72515)

- Higher torque capacity over stock
- Lockup clutch is slip-resistant so transmission fluids stay cooler and transmission life is prolonged

Banks Bullet
(P/N 66522-66523)

- Adds power safely to your vehicle
- Displays critical engine functions
- Engine safeguards
- Change power levels on-the-fly

Boost and Pyro Gauges
(P/N 64507)

- Keep your engine safe by monitoring vital engine parameters

Banks Diesel Tuner
EconoMind w/switch
(P/N 63725, 63793, 63795, 64507)

EconoMind w/iQ
(P/N 63807, 63808, 63817, 63818)
Six-Gun w/switch (P/N 61022, 63797)
Six-Gun w/iQ (P/N 63809, 63819)

- Adds power safely to your vehicle
- Engine and transmission safeguards
- Change power levels on-the-fly

Thermocouple

- Add a temperature limiting function to your Diesel Tuner

Banks Speed-Loader
(P/N 62981)

- Furthers the power output of the Banks Six-Gun and provides EGT limiting safety

Banks BigHead® Actuator
(P/N 24331)

- Achieves a higher peak boost over stock and gives you precise boost control that gives you crisp acceleration and more mid-range pulling power

Banks Stinger Systems
(P/N 49692-49699, 49708-49711, 49716-49721)

Contains:

- Ram-Air Intake system
- Monster Exhaust (single or dual)
- EconoMind Tuner w/ Banks iQ
- Big Head Wastegate Actuator

Banks PowerPack Systems
(P/N 49700-49707, 49712-49715, 49722-49727)

Contains:

- Ram-Air Intake system
- Monster Exhaust (single or dual)
- EconoMind Tuner w/ Banks iQ
- Big Head Wastegate Actuator
- Monster-Ram
- Techni-Cooler System

Banks Six-Gun Bundle
(P/N 49728-49735, 49744-49747, 49752-49757)

Contains:

- Ram-Air Intake system
- Monster Exhaust (single or dual)
- Six-Gun Tuner w/ Banks iQ
- Big Head Wastegate Actuator

Banks Big Hoss Bundle
(P/N 49736-49743, 49748-49751, 49758-49763)

Contains:

- Ram-Air Intake system
- Monster Exhaust (single or dual)
- Six-Gun Tuner w/ Banks iQ
- Big Head Wastegate Actuator
- Monster-Ram
- Techni-Cooler System

For More Information please call (888) 635-4565
or Visit us online @ www.bankspower.com

General Installation Practices

Dear Customer,

If you have any questions concerning the installation of your Banks Ram-Air System, please call our Technical Service Hotline at (888) 839-2700 between 7:00 am and 5:00 pm (PT). If you have any questions relating to shipping or billing, please contact our Customer Service Department at (888) 839-5600.

Thank you.

1. For ease of installation of your Banks Ram-air intake system, familiarize yourself with the procedure by reading the entire manual before starting work. This manual contains 16 pages of copy, illustrations and parts listing. If any pages are missing from this manual please call Gale Banks Engineering immediately for a replacement.
2. The exploded view of the Ram-Air assembly (pages 4-5) provides only general guidance. Refer to each step and section diagram in this manual for proper instruction.
3. Throughout this manual, the left side of the vehicle refers to the driver's side, and the right-side to the passenger's side.
4. Disconnect the ground cable from the battery before beginning work. If there are two batteries, disconnect both.

5. Route and tie wires and hoses a minimum of 6 inches away from exhaust heat, moving parts and sharp edges. Clearance of 8 inches or more is recommended where possible.

6. During installation, keep the work area clean. If foreign debris is transferred to any Banks system component, clean it thoroughly before installing.

7. When raising the vehicle, support it on properly weight-rated safety stands, ramps or a commercial hoist. Follow the manufacturer's safety precautions. Take care to balance the vehicle to prevent it from slipping or falling. When using ramps, be sure the front wheels are centered squarely on the topsides; put the transmission in park; set the parking brake; and place blocks behind the rear wheels.

Caution! Do not use floor jacks to support the vehicle while working under it. Do not raise the vehicle onto concrete blocks, masonry or any other item not intended specifically for this use.

Notification

The Banks Ram-Air Filter comes pre-oiled and no oiling is necessary for initial installation. Service the Filter as specified in the Filter Maintenance Section of this manual.

Tools Required:

- 3/8" drive ratchets with metric sockets
- Standard and Phillips head screwdrivers
- Standard and needle-nose pliers
- Clean shop towels or rags
- 5/16 nut driver
- Hack Saw
- Ruler

Table of Contents

Section 1 **6**
General Assembly

Section 2 **8**
Ram-Air Installation

Section 3 **19**
Filter Maintenance

Section 1

GENERAL ASSEMBLY

Figure 1

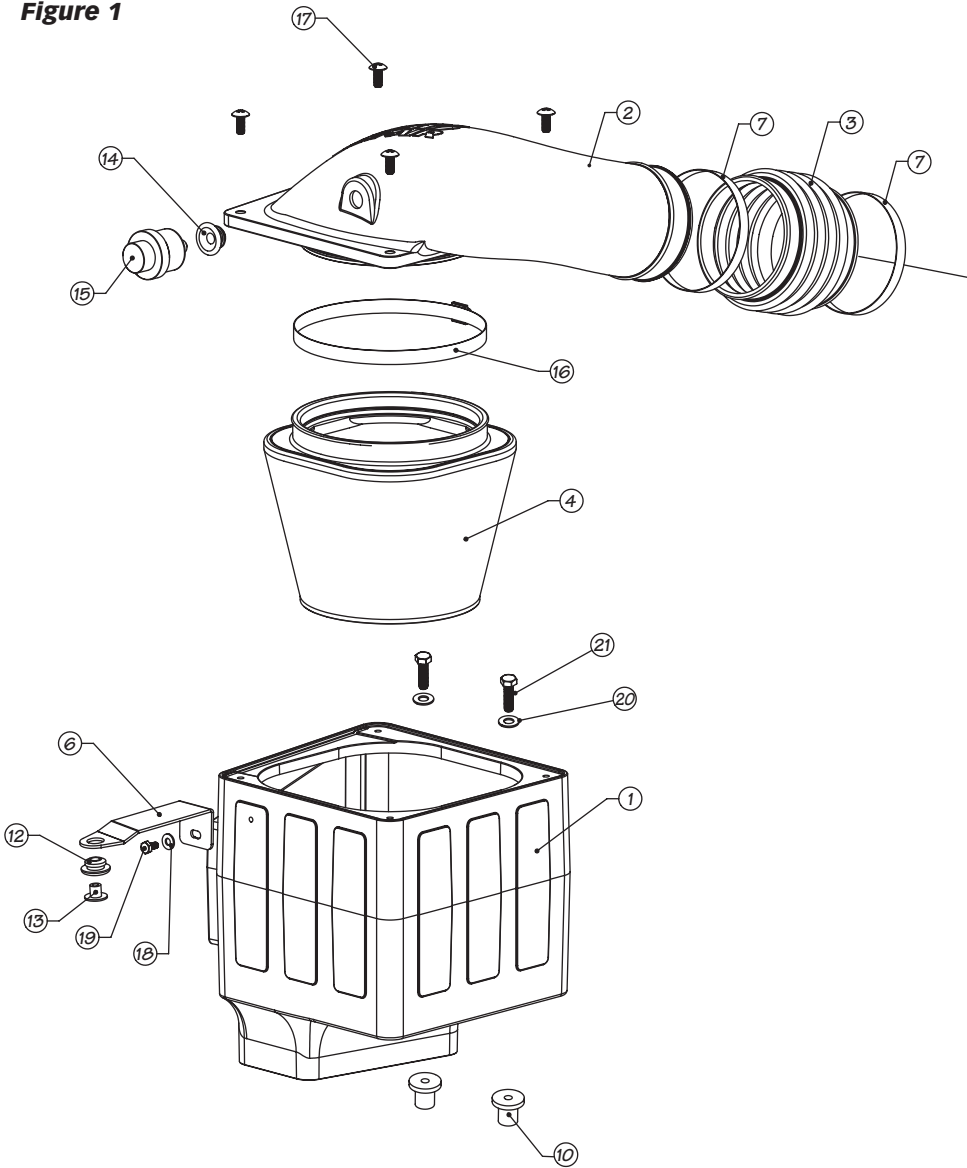

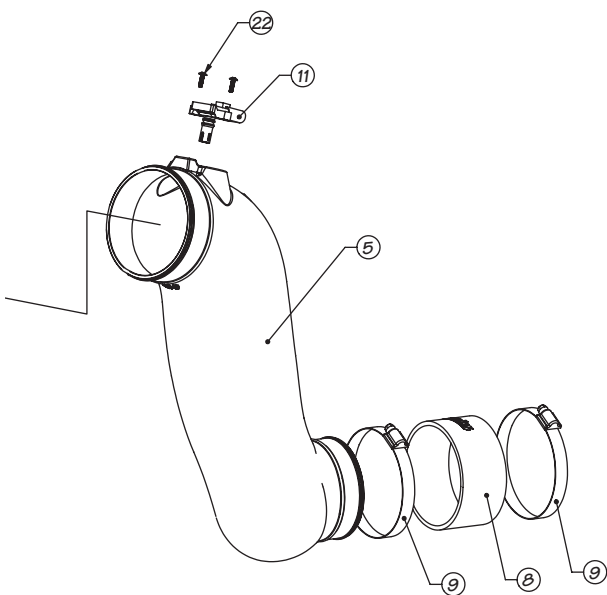

Item	Description	Part#	Qty
1	HOUSING, RAM-AIR FILTER	42146	1
2	COVER, RAM-AIR HOUSING	42147	1
3	HOSE, BELLOWS, 4.50 I.D.	94300	1
4	AIR FILTER ELEMENT, RAM-AIR SYST	42148	1
5	INTAKE TUBE, RAM-AIR SYSTEM	42149	1
6	BRACKET, SUPPORT, A/F HOUSING	42150	1
7	HOSE CLAMP, #72 w/LINER	92872	2
8	HOSE, COMPRESSOR INLET	94303	1
9	HOSE CLAMP, #64	92864	2
10	WELL-NUT, 3/8"-16, 1.06" LONG	91423	2
11	AIR TEMPERATURE SENSOR	OEM STOCK	1
12	GROMMET, STOCK AIR BOX	OEM STOCK	1
13	BUSHING, STOCK AIR BOX	OEM STOCK	1
14	GROMMET, FILTER MINDER	OEM STOCK	1
15	FILTER MINDER	OEM STOCK	1
16	HOSE CLAMP, #128	92928	1
17	SCREW, TRUSS HEAD, PHILLIPS, 5/16-18 X 3/4	91226	4
18	WASHER, SAE FLAT, GOLD ZINC, 1/4	91124	1
19	HEX BOLT, GR 5, ZINC, 1/4-20 X 1/2	91115	1
20	WASHER, SAE FLAT, ZINC, 3/8"	91402	2
21	HEX BOLT, GRADE 5, ZINC, 3/8"-16 X 1-1/4"	91428	2
22	SCREW, TRUSS HEAD, PHILLIPS, 6-32 x 1/2", SS	91719	2

Section 2

RAM-AIR INSTALLATION

Use the Bill of Materials Chart and the General Assembly Drawing to reference component nomenclature and location. Use caution when working in the engine compartment. Make sure the engine has been OFF for several hours and cool.

You are about to install the Banks Ram-Air Intake System. Read and follow all steps before working on the vehicle. Some components from the stock air intake system will remain in service. Take care when removing stock air intake components to not damage them.

1. Remove the nut and washer from radiator core support that secures the factory air housing and set aside. See **Figure 2**.
2. Loosen the hose clamp to the stock intake tube attached to the air housing.

3. Press tab and remove the Intake Air Temperature (IAT) sensor connector and set aside.

4. Remove the air housing by lifting up and out of the engine compartment.

Note: There may be slight resistance when removing the air housing feet due to rubber grommets.

5. Remove the factory stock rubber grommets attached to the outside of the battery tray bracket. See **Figure 3**.

6. Loosen the hose clamp, and then remove the factory air intake tube connection attached to the compressor inlet.

*Note: Simultaneously lift up and forward to remove the factory intake assembly. See **Figure 4***

7. Install the supplied rubber Well-Nut as shown in **Figure 5**. Install flange side up, flush with bracket.

Figure 2

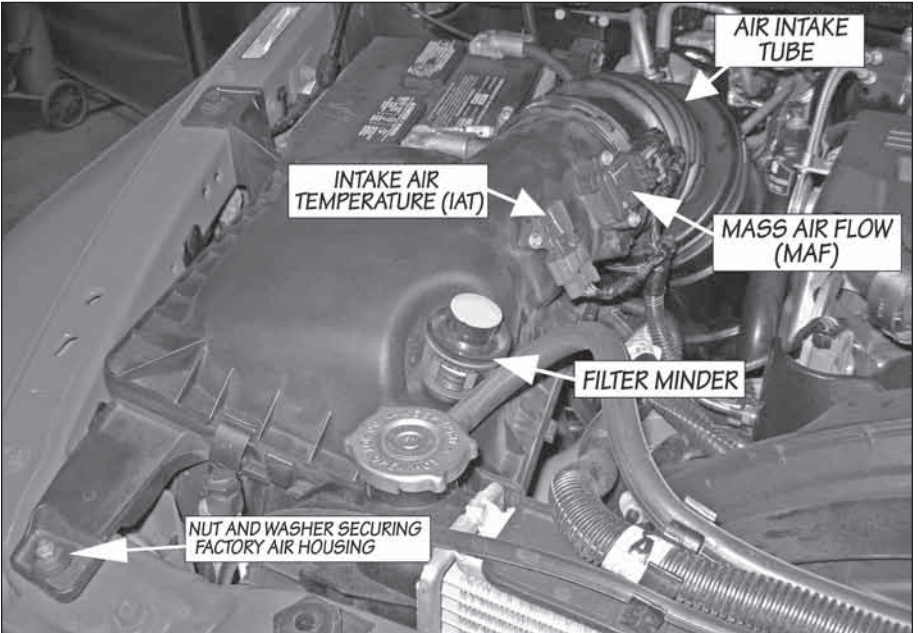

Figure 3

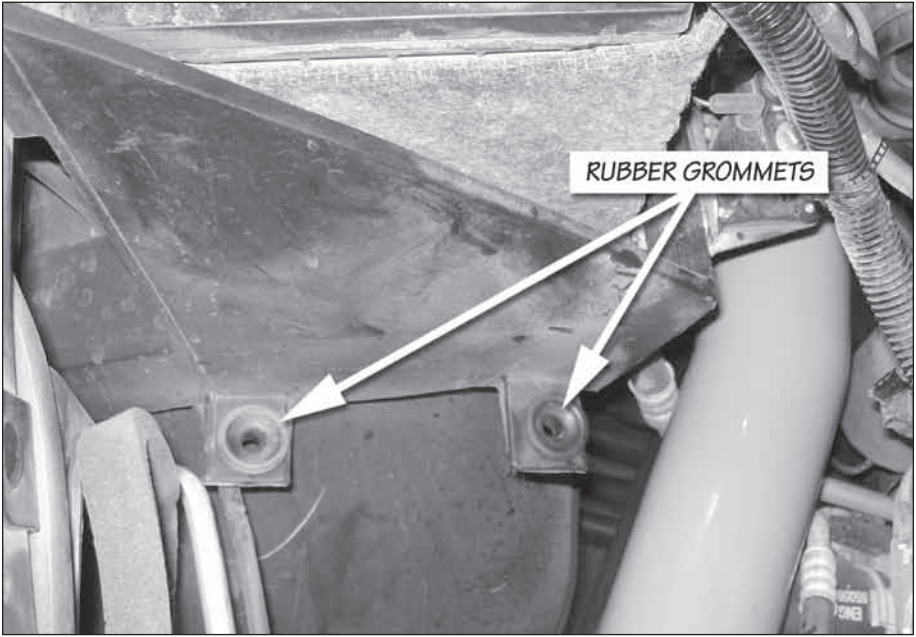

Figure 4



Figure 5



If installing the Banks Super Scoop then proceed to steps 8 thru 11. Otherwise, Skip to Step 12.

For Super Scoop Installation Only

8. Locate the Banks air housing. Using a ruler, measure one inch up from the bottom of the housing and repeat several times on all sides of the housing.

9. Make a line that traces the marks you have made around the box (see **Figure 6**).

10. Use your Hack Saw to cut along the line you have made in **Step 9** (see **Figure 7**).

Note: Cut housing as straight as possible, it will ease the deburr process.

11. After you have cut off the unneeded portion of the housing, deburr the bottom of the housing to smooth it out and to prevent debris

from entering the system.

12. Locate the Banks air housing and Banks air housing bracket in your kit. Hand tighten the air housing bracket to air housing using supplied bolt and washer. See **Figure 8**.

13. Remove the steel insert and rubber grommet from the factory air housing. See **Figure 9**.

14. Insert the rubber grommet flange side down into the air housing bracket.

15. Press in the steel insert and make flush to rubber grommet.

16. Install the Banks air filter housing. Align the radiator core support bolt to the air housing bracket hole. Align the air filter housing holes to threaded Well-Nuts installed in fender bracket. See **Figure 10**.

Note: The compressor supply and return lines may need to be slightly bent away from Banks air housing

Figure 6-For Banks Super Scoop Installation Only

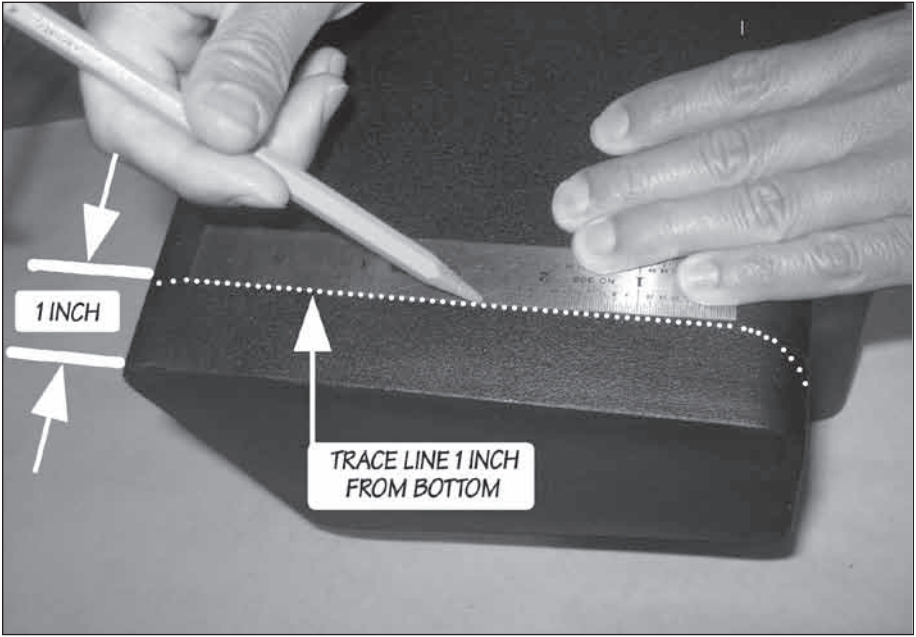

Figure 7-For Banks Super Scoop Installation Only

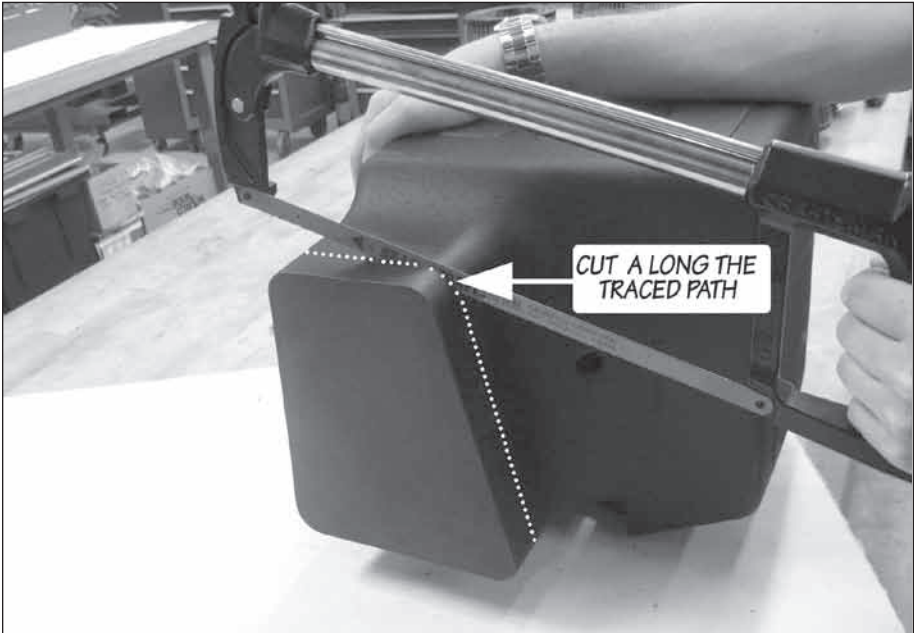

Figure 8



Figure 9



Figure 10



Figure 11

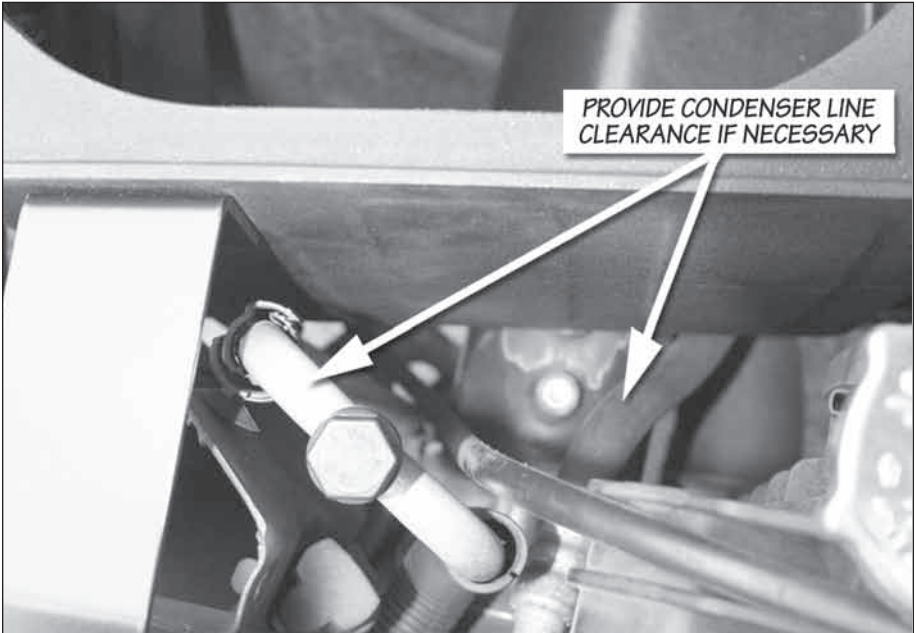
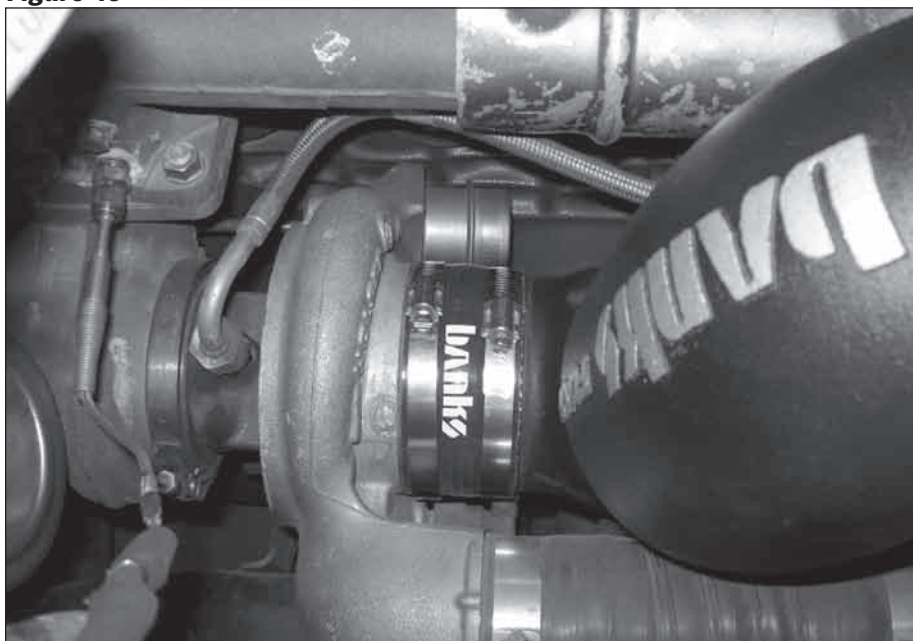

Figure 12



Figure 13



to provide clearance. Be careful not to break the condenser lines when adjusting clearance. See **Figure 11**.

17. Fasten the Banks air filter housing to the well-nuts by tightening the supplied $\frac{3}{8}$ bolt and washer until snug. Tighten the air housing bracket nut to the radiator core support. Tighten the bracket to the air housing using an open-end wrench. See **Figure 12**.

18. Connect the Banks hose to the Banks inlet tube and tighten hose clamp.

Note: Ensure Banks hose is up to and touching the raised bead on the Banks intake tube.

19. Install second hose clamp and leave loose.

20. Install Banks intake hose and intake tube to the compressor inlet.

*Note: Ensure hose is flush against step on compressor inlet. Hand tighten the hose clamp. See **Figure 13**.*

21. Place Banks air filter cover onto the Banks air filter housing.

22. Align intake tube with cover, and then tighten the hose clamp on turbo compressor inlet. See **Figure 14**.

23. Remove factory filter minder from factory air housing. Remove rubber grommet from factory air housing.

24. Install factory filter minder rubber grommet into the Banks cover. Insert the factory filter minder into rubber grommet.

25. Remove cover from housing. Install Banks bellows with hose clamps to Banks Intake tube.

26. Loosely install the hose clamp to the Banks air filter.

Figure 14

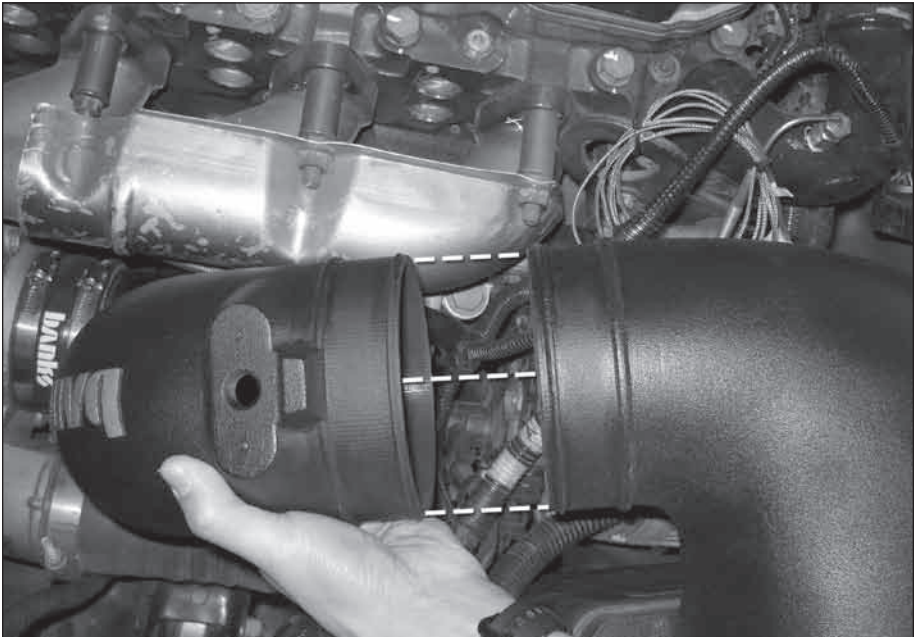

Figure 15

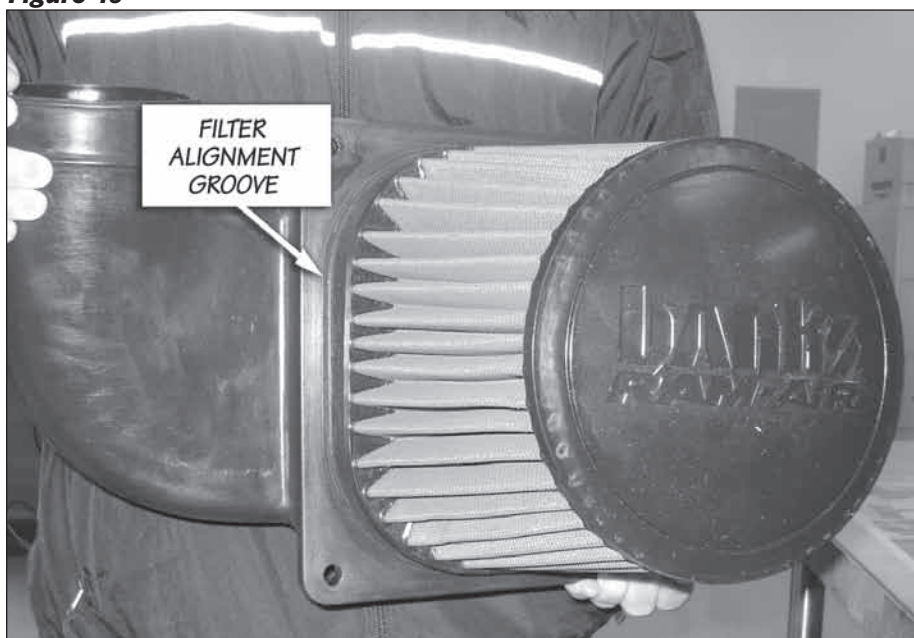
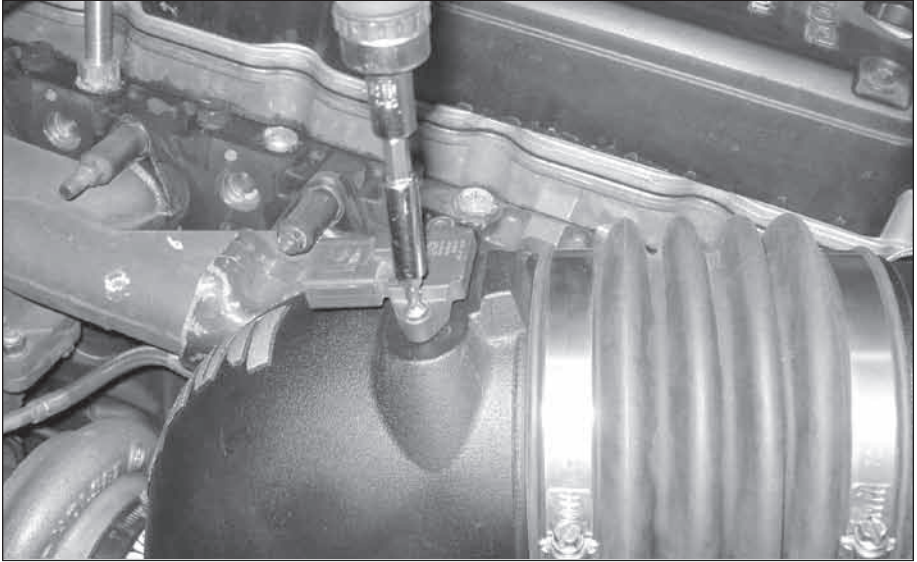

Figure 16



27. Install Banks air filter onto the Banks cover. Note the audible snap. Tighten the hose clamp on the air filter. Make sure the air filter is lined up with the alignment groove. See **Figure 15**.

Figure 17



28. Insert the Banks cover into the Banks bellows. Place cover on to housing and tighten the hose clamp. See **Figure 16**.

29. Using supplied screws fasten the banks cover to the air filter housing.

Figure 18

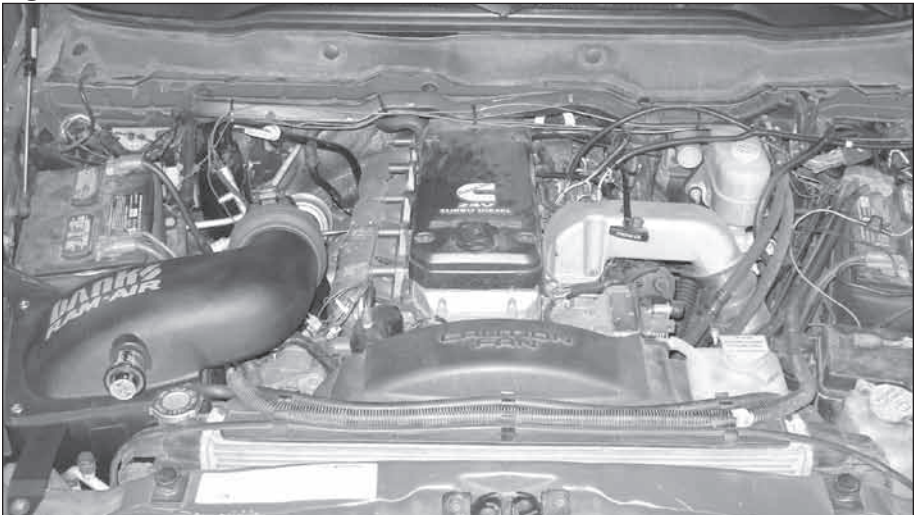

30. Remove the stock IAT sensor from the factory air housing.

31. Install IAT sensor into Banks Intake tube using supplied $\frac{6}{32}$ screws. See **Figure 17**.

Note: ensure o-ring is in good condition.

32. Connect the IAT connector to the IAT sensor.

Note: Route harness away from the exhaust manifold heat shield.

33. Re-connect battery grounds. You have successfully completed the installation of the Banks Ram-Air Intake system. See **Figure 18**. Make sure to go over all hose clamps for tightness and connectors for a sure fit. Make sure that the intake tube is not touching any engine components.

-END, SECTION 2-

Section 3

FILTER MAINTENANCE

Notification

The Banks Ram-Air Filter comes pre-oiled and no oiling is necessary for initial installation. Service the Filter as specified in this Section of this manual.

1. Service Banks Ram Air Filter every 50-100,000 miles on street-driven applications. Service more often in off-road or heavy-dust conditions. If an air-filter restriction gauge is installed, then clean the element when the air-filter restriction gauge enters the restrictive red zone. See **Figure 19**.

2. Use Banks Ram Air Filter cleaning system (part # 90094), available from Gale Banks Engineering to service the Air Filter. Follow the instructions included with the cleaning system to clean and re-oil your Banks Ram Air Filter. No gasoline cleaning, No

steam cleaning, No caustic cleaning solutions, No strong detergents, No high pressure car wash, No parts cleaning solvents. Any of these No's can cause harm to the cotton filter media plus SHRINK and HARDEN the rubber end caps.

CAUTION! Extremely fine dust from agriculture or off-road use will pull the oil from the element. Frequent re-oiling of the element's clean side might be required. Completely service when practicable. For extra protection use an air-filter sealing grease on rubber ends of the element. Service only with Banks Ram-Air-filter cleaner and Banks Ram-Air-filter oil.

-END, SECTION 3-

Figure 19 Typical air-filter restriction gauge

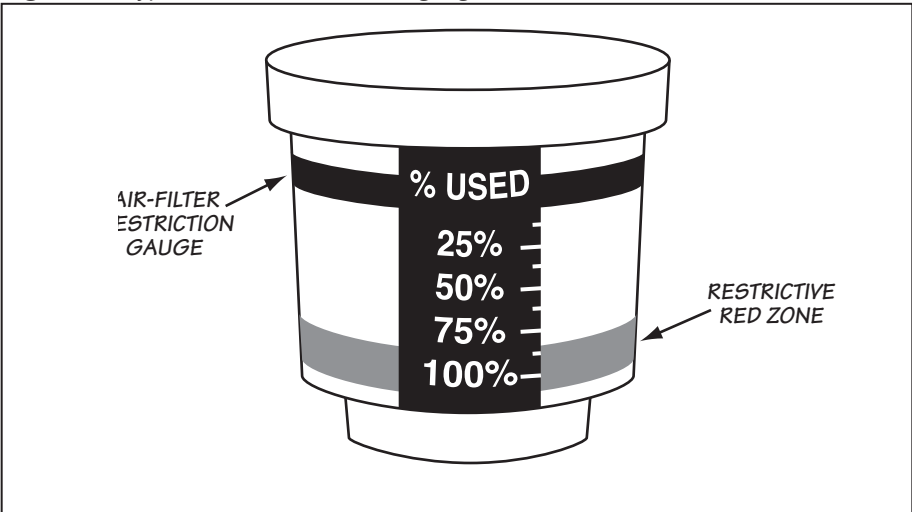

Gale Banks Engineering
546 Duggan Avenue • Azusa, CA 91702
(626) 969-9600 • Fax (626) 334-1743

Product Information & Sales: (888) 635-4565

bankspower.com