



INSTALLATION INSTRUCTIONS

300 W PONTIAC WAY CLOVIS, CA 93612 local: 559-875-0222 fax: 559-876-2249 toll free: 800-445-3767

25007
LIFT / LOWERING STRUT
2015+ FORD F-150 2WD (+1" to -3")
2015+ FORD F-150 4WD (OEM to -2")

Thank you for being selective enough to choose our high quality BELLTECH PRODUCT. We have spent many hours developing our line of products so that you will receive maximum performance with minimum difficulty during installation.

- Note:** Confirm that all of the hardware listed in the parts list (page 6) is in the kit. **DO NOT** begin installation if any part is missing. Read the instructions thoroughly before beginning this installation.
- Warning:** **DO NOT** work under a vehicle supported by only a jack. Place support stands securely under the vehicle in the manufacturer's specified locations unless otherwise instructed.
- Warning:** **DO NOT** drive vehicle until all work has been completed and checked. Torque all hardware to values specified.
- Reminder:** Proper use of safety equipment and eye/face/hand protection is absolutely necessary when using these tools to perform procedures!
- Note:** It is very helpful to have an assistant available during installation.

RECOMMENDED TOOLS:

- Properly rated floor jack and support stands
- Wheel chocks
- Metric socket set up to 27mm
- Metric combination wrench set up to 27mm
- SAE combination wrench set up to ¾"
- Torque wrench
- Ball Joint puller
- Die Grinder with carbide metal cutting bit
- Safety Glasses

JACKING, SUPPORTING AND PREPARING THE VEHICLE

- a) Block the rear wheels of the vehicle with appropriate wheel chocks. Make sure the vehicle's transmission is in "Park" (automatic) or 1st gear (manual). Activate the parking brake.
- b) Loosen, but **DO NOT REMOVE**, the front wheel lug nuts.
- c) Lift the front of the vehicle off the ground using a properly rated floor jack. Lift the vehicle so that the front tires are approximately 6-8 inches off the ground surface.
- d) Support the vehicle using support stands rated for the vehicle's weight. The stands should be positioned in the factory specified locations (refer to owners manual). Prior to lowering the vehicle onto stands, make sure the supports will securely contact the chassis. It is very important that the vehicle is properly supported during this installation to prevent frame damage and

personal injury! Make sure that the support stands are properly placed prior to performing the following procedures.

- e) Lower the vehicle slowly onto the stands, checking that they properly and securely contact the frame rails as described above before placing the vehicles weight fully on them.
- f) Remove the front wheels from the vehicle.

SAFETY REMINDER: Check for safe vehicle stability before proceeding under the vehicle to begin the following procedures. Never work under a vehicle supported by only a jack. Always use properly rated support stands to support the vehicle.

1. REMOVING THE OEM STRUT

- 1a) Unbolt the brackets holding the brake and ABS lines from the spindle and the frame. Also remove the plastic clip holding the ABS line to the frame and brake line bracket. Be careful not to damage any of the lines. **(photo 1&2)**

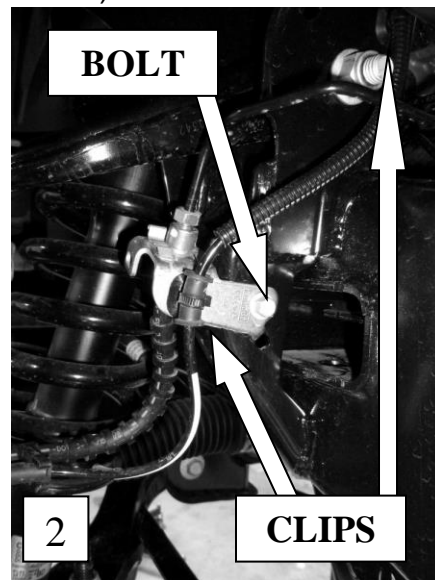
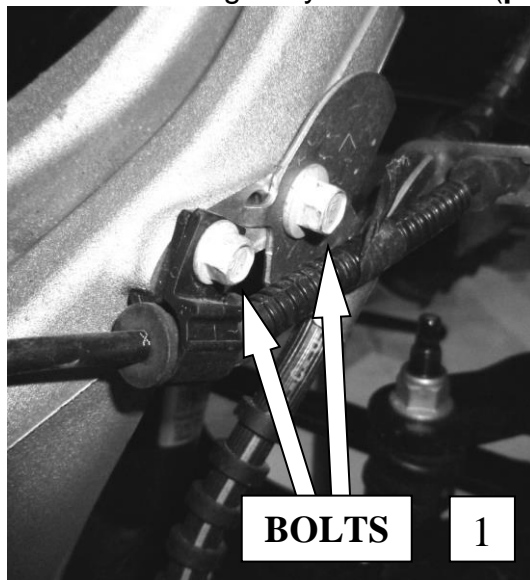

- 1b) Loosen and remove the upper nuts from the sway bar end links. **(photo 3)**
- 1c) Loosen and remove the nuts securing the lower strut mount to the control arm. **(photo 4)**

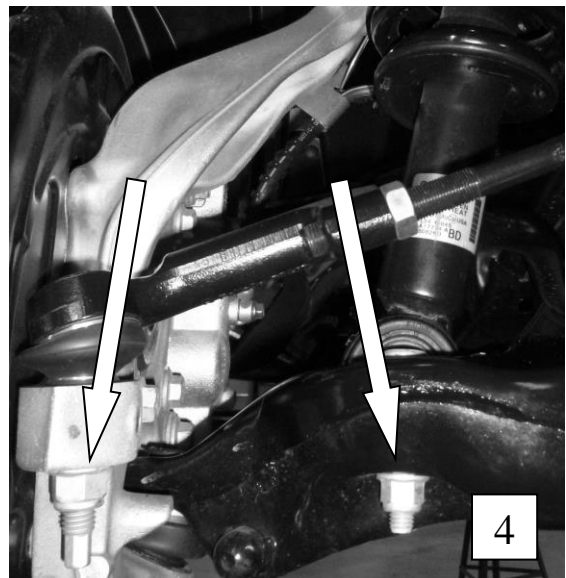

- 1d) Remove the nut securing the tie rod end to the steering knuckle and remove the tie rod end from the steering knuckle. This may require taping the side of the tie rod end boss with a hammer to unseat the taper. **(photo 4)**
- 1e) Loosen and remove the nut securing the upper ball joint to the steering knuckle. **Please note that the upper control arm may be under tension from the bushing and that after removing the ball joint the lower control arm will no longer be supported and may drop downward. Be careful to not allow the brake or ABS lines to become stretched or damaged during this process.** Break the ball joint free from the steering knuckle using the proper ball joint puller. **(photo 5)**
- 1f) Push the steering knuckle and lower control arm down until the lower shock studs are clear from the control arm. Again, do not allow the brake or ABS lines to become stretched or damaged during this process. **(photo 6)**
- 1g) Remove the 3 nuts securing the upper strut mount to the chassis.
- 1h) Mark the outboard side of the spring and top mount to assist with proper re-assembly and installation. Remove the strut from the chassis.

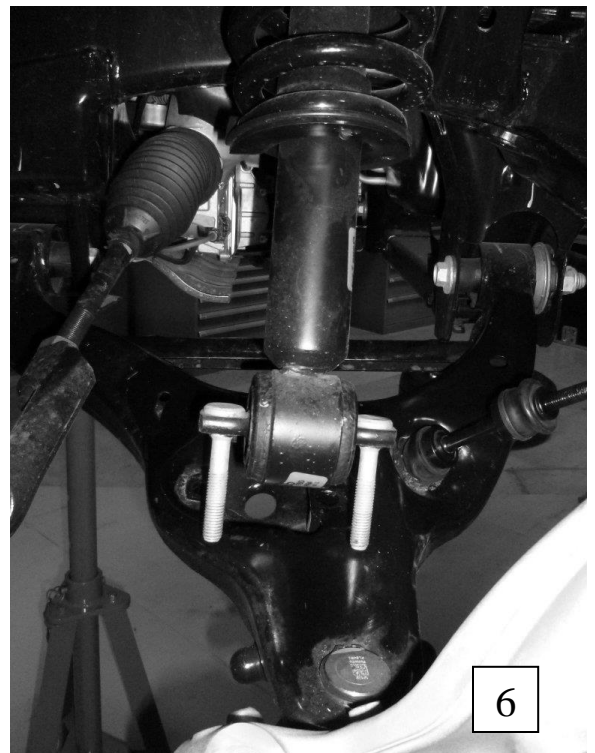
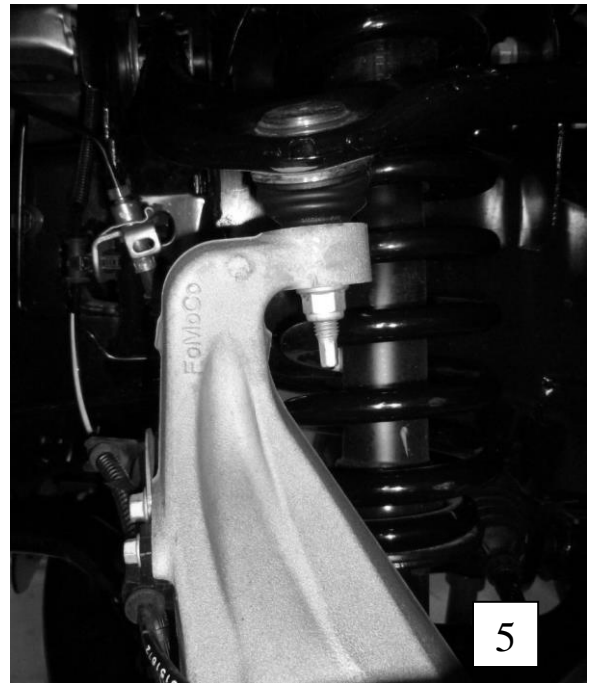

2. STRUT DISASSEMBLY

CAUTION! The coil springs is held in place under extreme compression. Belltech recommends the use of a heavy duty spring compression suitable for truck springs to perform this step. If unsure of your spring compressor capabilities, take this to a professional installer. Use caution during the following steps to avoid personal injury and/or damage to vehicle.

- 2a) Mount the entire spring/strut assembly in the spring compressor fixture. To ease the installation of the new strut, mark a white line down the center of each piece of the assembly for alignment purposes. Note the orientation of the upper mount relative to the bottom shock bar pin and studs.
- 2b) Compress the spring until the spring is no longer holding tension against the upper and lower spring perch.
- 2c) Hold the strut shaft from spinning and remove the top center nut from the strut. The shock will need to be supported as the nut is removed as it will fall if not supported. Remove the shock and bump stop from the assembly.

3. STRUT ASSEMBLY

3a) Refer to the chart below to determine the size and number of rings to install for the desired ride height.

Caution: The chart below is designed to use the Belltech 25007 with the stock vehicle spring. Combining the Belltech 25007 with a lowering spring will require adjusting the ring quantities to adjust for the lowered spring height. Belltech does not recommend total lowering of the vehicle beyond the lowest specification on this chart (3" total lowering ford 2WD and 2" total for 4WD) as the vehicle may not be able to be aligned and the performance of the shock may be greatly decreased

		NUMBER OF RINGS INSTALLED ON STRUT FOR 2WD							
ITEM DESCRIPTION	3" Lowering	2.5" Lowering	2" Lowering	1.5" Lowering	1" Lowering	.5" Lowering	OEM Height	.5" Lifting	1" Lifting
16mm (0.63") Ring	0	0	1	1	2	2	3	3	3
8mm (0.315") Ring	0	1	0	1	0	1	0	1	2
		NUMBER OF RINGS INSTALLED ON STRUT FOR 4WD							
ITEM DESCRIPTION	3" Lowering	2.5" Lowering	2" Lowering	1.5" Lowering	1" Lowering	.5" Lowering	OEM Height	.5" Lifting	1" Lifting
16mm (0.63") Ring	X	X	2	3	3	3	3	X	X
8mm (0.315") Ring	X	X	1	0	1	2	3	X	X

- 3b) Assemble the desired number of rings on to the Belltech Street Performance shock body. Slide the supplied Belltech spring perch on to the shock above the rings. See diagram for orientation.
- 3c) Install the supplied Belltech black plastic vent disk on to the shock. The vent disk will sit around the rod and rest on top of the shock body.
- 3d) Install the supplied Belltech bump stop on to the shock rod with the smaller end facing downward.
- 3e) Insert the assembled shock in to the compressed spring and upper spring perch. Secure the shock in to the top mount using the supplied nylon lock nut. Tighten lock nut to 33 ft./lb.
- 3f) Align the strut so the bar pin slopes downward to the outside of the vehicle. Use marking made during disassembly to ensure proper alignment. Uncompressed the spring carefully ensuring proper seating in the upper and lower spring mounts.

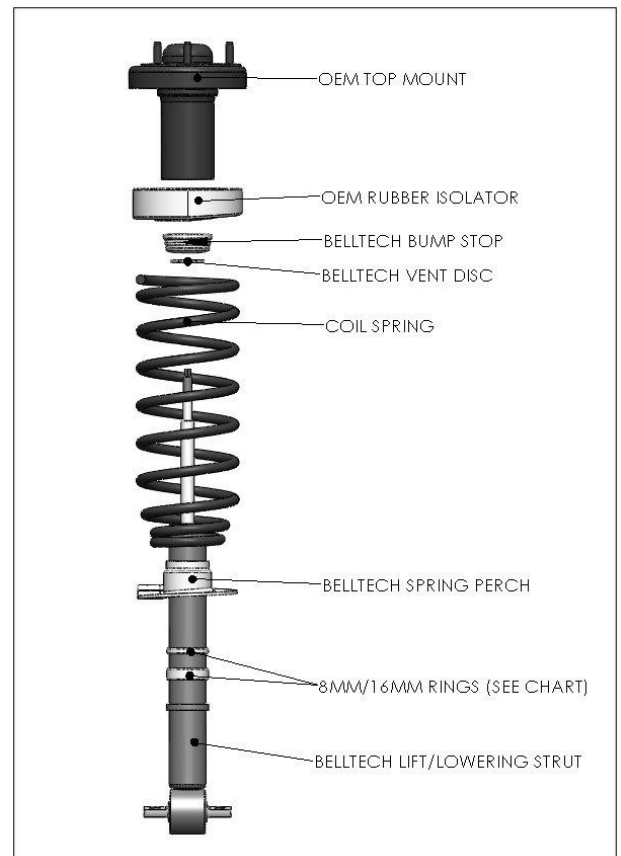

4. INSTALLING STRUT

- 4a) Install the top mount in to the chassis and secure with the original nuts. Torque nuts to factory specifications.
- 4b) Attach the lower strut mount to the lower control arm using the supplied Bolts washers and nylon lock nuts. Torque the supplied nuts to 60 ft/lbs.
- 4c) Attach the upper ball joint and tie rod ends to the steering knuckle. Torque nuts to factory specifications. Do not over tighten.
- 4d) Re-attach the upper end link to the sway bar and tighten to factory specification.
- 4e) Re-attach all brake and ABS lines using OEM bolts and re-attach plastic clips to their original location

5. ALIGNMENT MODIFICATION

This process is not normally needed for the Belltech 1" drop but is recommended when lowering more than 1". This process will allow for additional adjustment to obtain factory spec alignment. If lowering vehicle less than 2", please skip to step 6

- 5a) Remove both bolts securing the lower control arm to the chassis. **(photo 7)**
- 5b) Pull the lower control arm down below the chassis.
- 5c) Scribe a line $\frac{1}{2}$ " inward from the edge of the factory alignment slot in the chassis. This will need to be done to all 4 slots on each side of the vehicle. **(photo 8)**
- 5d) Use a die grinder with a carbide cutting tip to carefully elongate the slot towards the center of the vehicle. Do not elongate beyond the $\frac{1}{2}$ " outlined as this will allow the control arm to contact the frame.
- 5e) Remove any burs after grinding and paint the exposed surfaces to prevent corrosion.
- 5f) Reinstall the lower control arms with OEM bolts and torque to factory specifications.

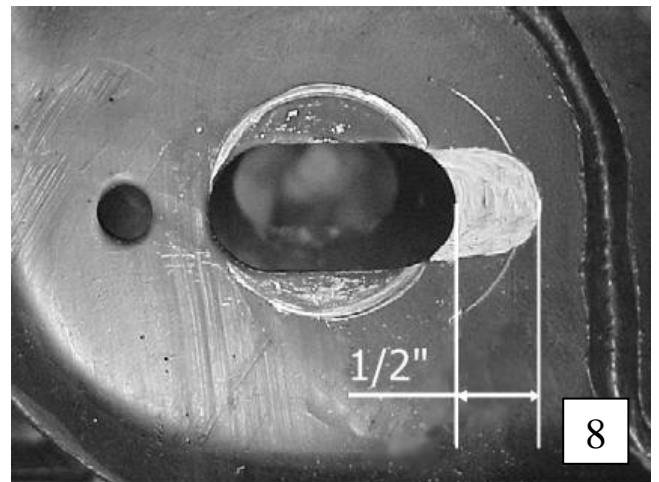
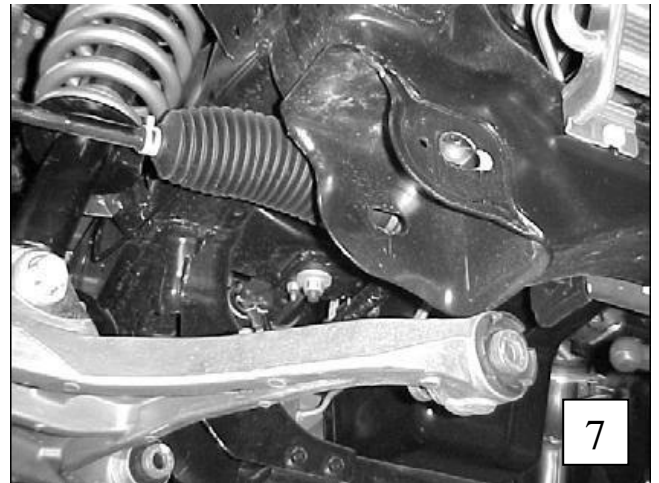

6. FINALIZING THE INSTALLATION

- 6a) All hardware being fastened to the vehicle's original fastening points should be torqued to the proper specifications. To prevent chassis damage, never over-torque the hardware.
- 6b) Check brake hoses and other components for any possible interference.
- 6c) Lift the vehicle and remove the support stands. Carefully lower the vehicle to the ground.
- 6d) **Front end alignment is required immediately following this installation.**
- 6e) Test-drive the vehicle in a remote location so that you can become accustomed to the revised driving characteristics and handling. Be aware that the vehicle will handle substantially different now that it has been modified.
- 6f) Installation is complete. Check all of the hardware and re-torque at intervals for the first 10, 100, 1000 miles.

Parts List: 25007

Part #	Description	Quantity
25007-001	SHOCK	1
112058	HHCS M14-1.5 X 70MM (LOWER STRUT MOUNT)	2
112298	NYLON LOCK NUT M14-1.5	2
110660	WASHER	2
25012-002	SPRING PERCH	1
25003-016	16MM SPACER	3
25003-008	8MM SPACER	3
4927-001	BUMP STOP	1
65210031	VENT DISK	1



INSTALLATION INSTRUCTIONS

2352

2" LOWERING SPINDLE

300 W. Pontiac Way Clovis, CA 93612

toll free: 1-800-445-3767

web: www.belltech.com

15-18 FORD F150 2WD CREW-CAB/ REG CAB

>>> MUST USE 20" WHEELS OR LARGER <<<

Thank you for being selective enough to choose our high quality BELLTECH PRODUCT. We have spent many hours developing our line of products so that you will receive maximum performance with minimum difficulty during installation

Note: Confirm that all of the hardware listed in the parts list is in the kit. **Do not** begin installation if any part is missing. Read the instructions thoroughly before beginning this installation.

Warning: **DO NOT** work under a vehicle supported by only a jack. Place support stands securely under the vehicle in the manufacturer's specified locations unless otherwise instructed.

Warning: **DO NOT** drive vehicle until all work has been completed and checked. Torque all hardware to values specified.

Reminder: Proper use of safety equipment and eye/face/hand protection is absolutely necessary when using these tools to perform procedures!

Note: It is very helpful to have an assistant available during installation. Some provided images may show additional holes / hardware, if instructions do not reference discrepancies please continue with the provided steps.

RECOMMENDED TOOLS:

- Properly rated floor jack and two (2) support stands
- Wheel chocks
- 1/2" drive torque wrench
- Metric socket wrench set
- Metric wrench set
- Tape measure
- Safety Glasses

KIT INSTALLATION

WE RECOMMEND that a qualified mechanic, at a properly equipped facility, perform such installation. **WE RECOMMEND** that the installation be performed on a firm, flat and level surface such as seasoned asphalt or concrete.

The use of safe, and proper equipment, is very important!

1) JACKING, SUPPORTING AND PREPARING THE VEHICLE

- a) Block the rear wheels of the vehicle with appropriate wheel chocks. Make sure the vehicle's transmission is in "PARK" (automatic) or 1st gear (manual). Activate the parking brake.
- b) Loosen, but **DO NOT REMOVE** the front wheel lug nuts.
- c) Lift the front of the vehicle off the ground using properly rated floor jack. Lift the vehicle so that the front tires are approximately 6-8 inches off the ground surface.
- d) Support the vehicle using two (2) support stands, rated for the vehicle's weight. The stands should be positioned in the factory specified locations. (Refer to the vehicle Owner's Manual) Prior to lowering the vehicle onto the stands, make sure the supports will securely contact the chassis. **It is very important that the vehicle is properly supported during this installation to prevent frame damage and personal injury! Make sure that the support stands are properly placed prior to performing the following procedures.**
- e) Lower the vehicle onto the stands slowly and check for possible interference with any brake lines, wire and or cables.

!SAFETY REMINDER!

Check for safe and vehicle stability before proceeding under the vehicle to the begin the following procedures. Never work under a vehicle supported by **ONLY a jack. Always use properly rated support stands to support the vehicle.**

2) STEERING KNUCKLE REMOVAL

- a) Starting on the passenger's side of the vehicle; remove the wheel from the vehicle. **(PHOTO 1)**
- b) Remove the steering arm tie rod end. **(PHOTO 2)**
- c) Remove the brake line bracket attached to the steering knuckle. **(PHOTO 3)**
- d) Remove the brake caliper assembly from the steering knuckle. **(PHOTO 4)** With a metal hook/wire or Zip-tie, attach the caliper to chassis so that it doesn't dangle and damage the brake line. Remove the Rotor.

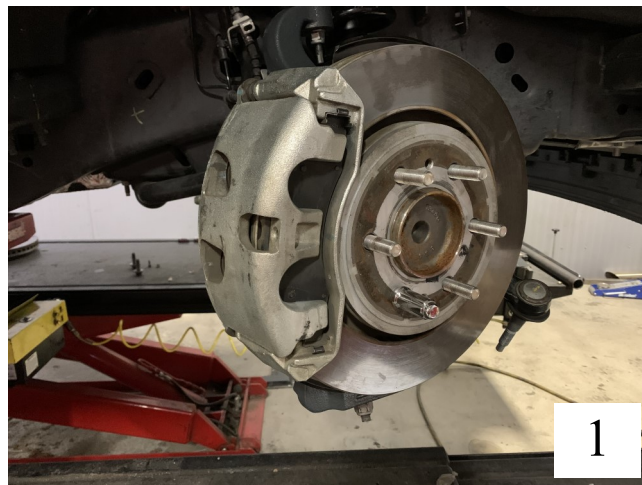

- e) Remove the OEM dust shield. **(PHOTO 5).**



2) STEERING KNUCKLE REMOVAL cont...

- f) Remove the ABS sensor from the hub. **(PHOTO 6)**
- g) Unthread the upper control arm ball joint nut, but do not completely remove. **(PHOTO 7)**
- h) Use a hammer, and hit the side of the ball joint to release it from the steering knuckle. **(PHOTO 8)**
- i) Unthread the lower control arm ball joint nut, but do not completely remove.
- j) Use a hammer, and hit the side of the ball joint to release if from the steering knuckle.

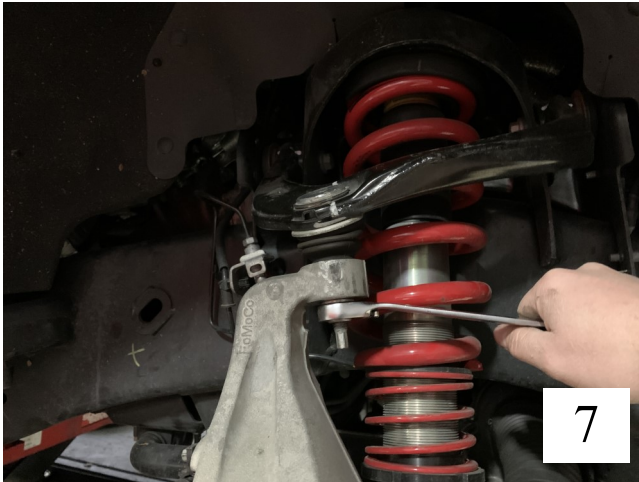

- k) Remove the upper ball joint nut and remove the upper ball joint from the steering knuckle **(PHOTO 9)**
- l) Repeat step for the lower ball joint.
- m) Once steering knuckle is removed, remove the back hub bolts; remove hub from OEM steering knuckle. **(PHOTO 10)**

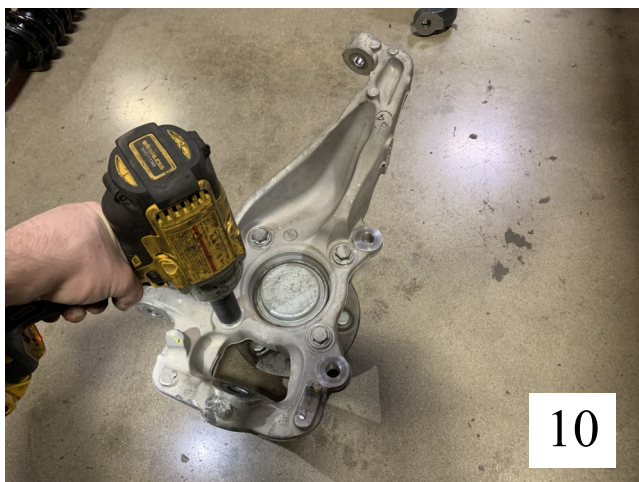

3) **BELLTECH STEERING KNUCKLE INSTALLATION**

- a) Install the OEM hub onto the BELLTECH 2352 steering knuckle.. **(PHOTO 11)** Make sure the ABS sensor is facing upward. **(PHOTO 12)**



- b) Install the *BELLTECH* steering knuckle onto the bottom ball joint first. Secure the bottom nut; hand tight only. **(PHOTO 13)**
- c) Install the upper ball joint on to the *BELLTECH* steering knuckle, Secure upper ball joint nut; hand tight only **(PHOTO 14)**

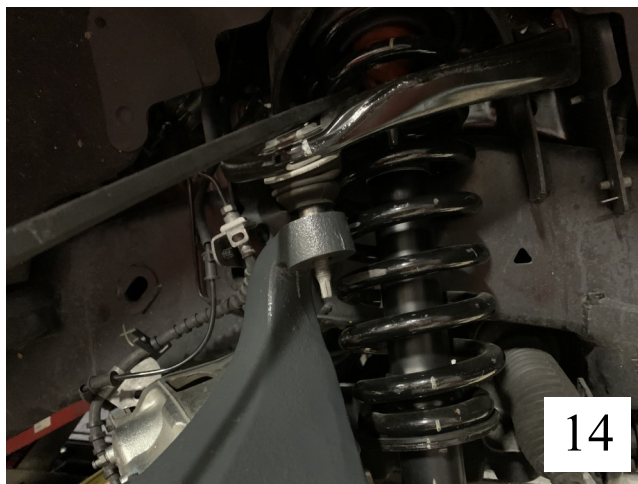
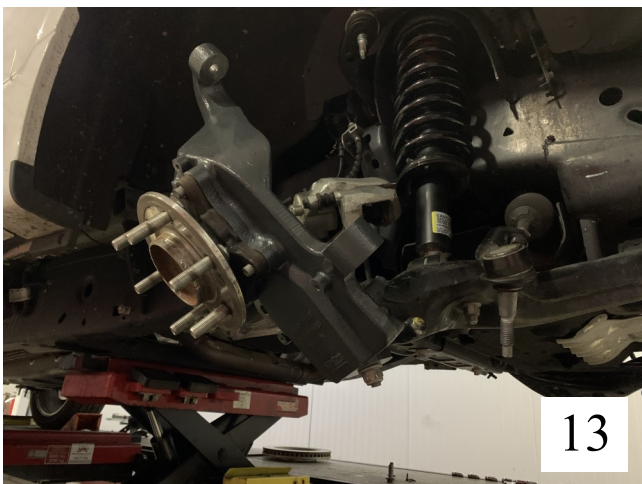

- d) Tighten the upper ball joint and bottom ball joint **(PHOTO 15 & 16)**

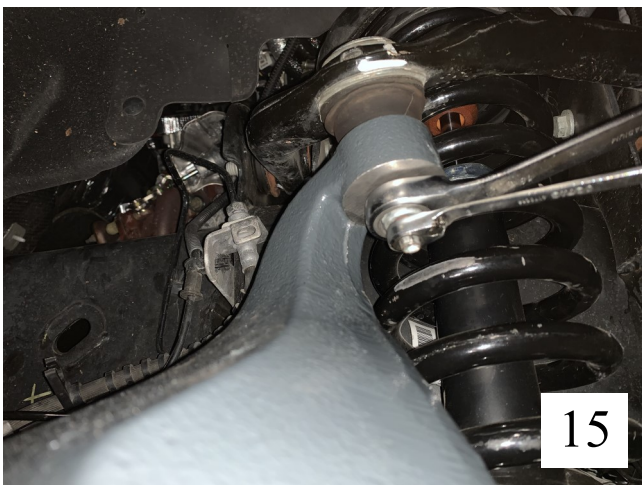

3) **BELLTECH STEERING KNUCKLE INSTALLATION cont...**

e) Install the ABS sensor onto the BELLTECH 2352 steering knuckle. **(PHOTO 17)**

f) Install the OEM dust shield and rotor onto the *BELLTECH* steering knuckle. **(PHOTO 18)**

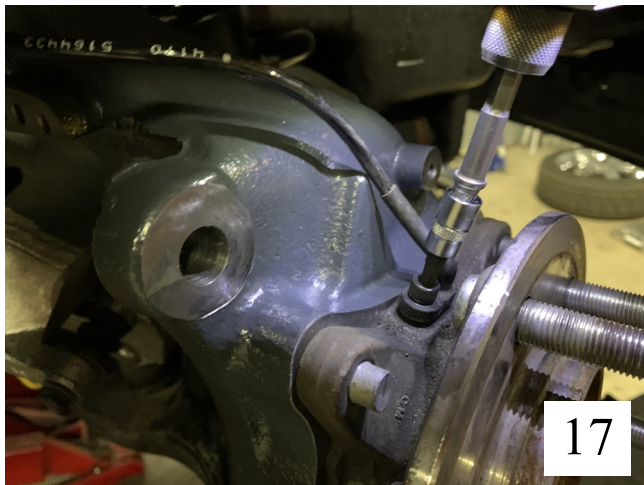

g) Install the rotor & caliper onto the *BELLTECH* steering knuckle using the OEM bolts.

(PHOTO 19 & 20)

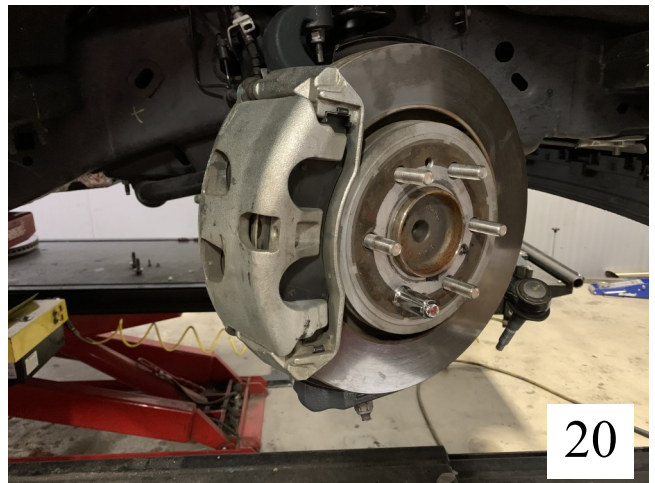
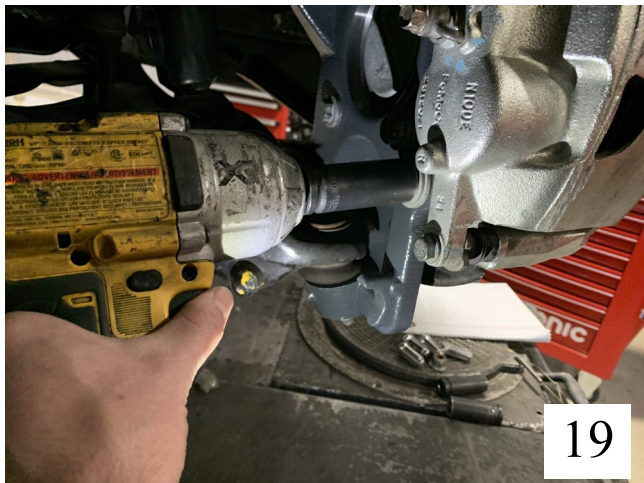

h) Install the OEM brake line brackets onto the *BELLTECH* steering knuckle. **(PHOTO 21)**

i) Install and tighten the steering tie rod onto the *BELLTECH* steering knuckle. **(PHOTO 22)**



3) **BELLTECH STEERING KNUCKLE INSTALLATION cont...**

j) Double check all the OEM brake lines are secured. (PHOTO 23)

k) Installation complete. Repeat process on driver side. (PHOTO 24)

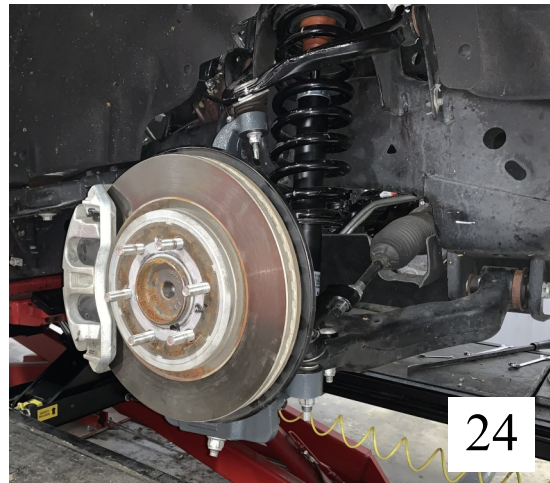

4) **FINALAZING INSTALLATION**

- a) Check that all components and fasteners have been properly installed, tightened and torqued.
- b) Check the brake hoses, and any other components for any possible interference.
- c) Install both passenger and driver side wheels.
- d) Lift the vehicle and remove the support stands. Carefully lower the vehicle to the ground.
- e) Visually inspect the wheel alignment after the vehicle has been set down and rolled to relieve any tension. It may be necessary to manually adjust the toe on the steering arms before the vehicle is driven.
- f) Test-drive the vehicle in a remote location so that you can become accustomed to the revised driving characteristics and handling. Be aware that the vehicle will handle substantially different now that it has been modified.
- g) We recommend the vehicle be taken in to a qualified wheel alignment facility to be aligned to factory specifications. This should be done after the vehicle has been test driven and all modifications have been completed.
- h) Check **ALL** of the hardware and re-torqued at intervals for the first 10, 100, 1000 miles.

PARTS LIST		
PART #	DESCRIPTION	QUANTITY
2352-325	STEERING KNUCKLE LH	1
2352-425	STEERING KNUCKLE RH	1



INSTALLATION INSTRUCTIONS

300 W PONTIAC WAY CLOVIS, CA 93612 local: 559-875-0222 fax: 559-876-2249 toll free: 800-445-3767

25007 LIFT / LOWERING STRUT +1" TO -3" 2015+ FORD F-150 2WD

Thank you for being selective enough to choose our high quality BELLTECH PRODUCT. We have spent many hours developing our line of products so that you will receive maximum performance with minimum difficulty during installation.

- Note: Confirm that all of the hardware listed in the parts list (page 6) is in the kit. **DO NOT** begin installation if any part is missing. Read the instructions thoroughly before beginning this installation.
- Warning:** **DO NOT** work under a vehicle supported by only a jack. Place support stands securely under the vehicle in the manufacturer's specified locations unless otherwise instructed.
- Warning:** **DO NOT** drive vehicle until all work has been completed and checked. Torque all hardware to values specified.
- Reminder: Proper use of safety equipment and eye/face/hand protection is absolutely necessary when using these tools to perform procedures!
- Note: It is very helpful to have an assistant available during installation.

RECOMMENDED TOOLS:

- Properly rated floor jack and support stands
- Wheel chocks
- Metric socket set up to 27mm
- Metric combination wrench set up to 27mm
- SAE combination wrench set up to 3/4"
- Torque wrench
- Ball Joint puller
- Die Grinder with carbide metal cutting bit
- Safety Glasses

JACKING, SUPPORTING AND PREPARING THE VEHICLE

- a) Block the rear wheels of the vehicle with appropriate wheel chocks. Make sure the vehicle's transmission is in "Park" (automatic) or 1st gear (manual). Activate the parking brake.
- b) Loosen, but **DO NOT REMOVE**, the front wheel lug nuts.
- c) Lift the front of the vehicle off the ground using a properly rated floor jack. Lift the vehicle so that the front tires are approximately 6-8 inches off the ground surface.
- d) Support the vehicle using support stands rated for the vehicle's weight. The stands should be positioned in the factory specified locations (refer to owners manual). Prior to lowering the vehicle onto stands, make sure the supports will securely contact the chassis. It is very important that the vehicle is properly supported during this installation to prevent frame damage and personal injury! Make sure that the support stands are properly placed prior to performing the following procedures.

- e) Lower the vehicle slowly onto the stands, checking that they properly and securely contact the frame rails as described above before placing the vehicles weight fully on them.
- f) Remove the front wheels from the vehicle.

SAFETY REMINDER: Check for safe vehicle stability before proceeding under the vehicle to begin the following procedures. Never work under a vehicle supported by only a jack. Always use properly rated support stands to support the vehicle.

1. REMOVING THE OEM STRUT

- 1a) Unbolt the brackets holding the brake and ABS lines from the spindle and the frame. Also remove the plastic clip holding the ABS line to the frame and brake line bracket. Be careful not to damage any of the lines.(photo 1&2)

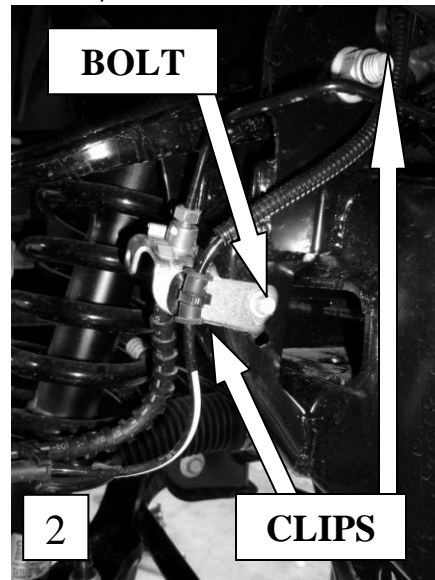
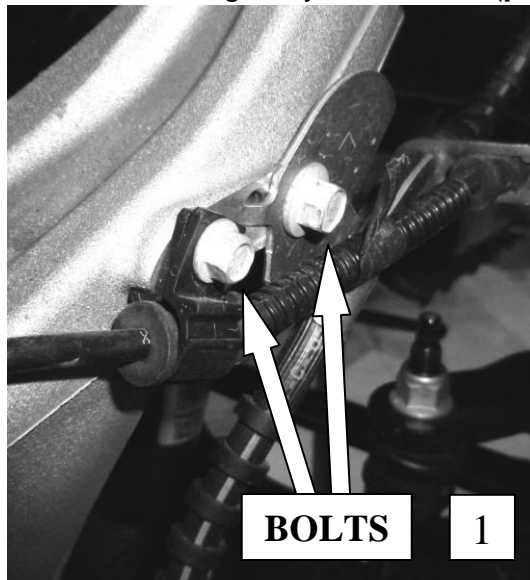

- 1b) Loosen and remove the upper nuts from the sway bar end links. (photo 3)
- 1c) Loosen and remove the nuts securing the lower strut mount to the control arm.(photo 4)

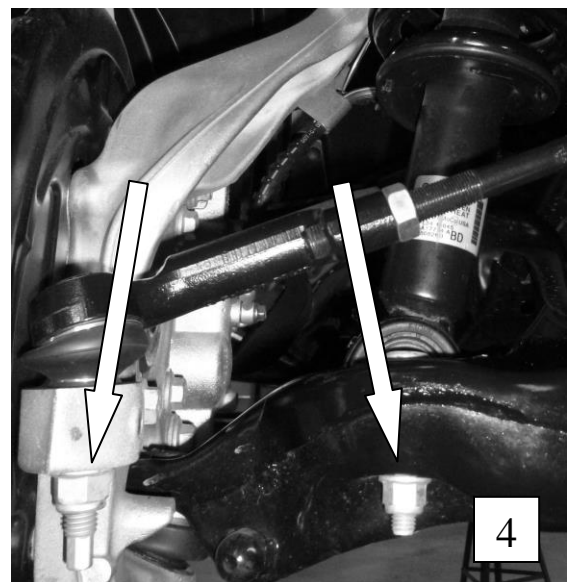
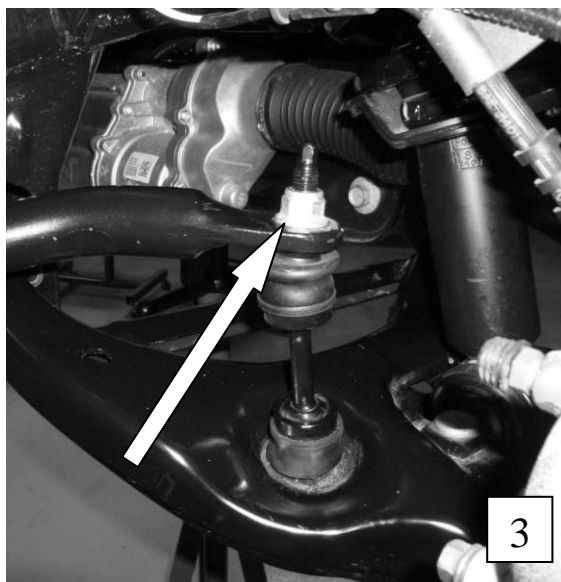

- 1d) Remove the nut securing the tie rod end to the steering knuckle and remove the tie rod end from the steering knuckle. This may require taping the side of the tie rod end boss with a hammer to unseat the taper. **(photo 4)**
- 1e) Loosen and remove the nut securing the upper ball joint to the steering knuckle. **Please note that the upper control arm may be under tension from the bushing and that after removing the ball joint the lower control arm will no longer be supported and may drop downward. Be careful to not allow the brake or ABS lines to become stretched or damaged during this process.** Break the ball joint free from the steering knuckle using the proper ball joint puller. **(photo 5)**
- 1f) Push the steering knuckle and lower control arm down until the lower shock studs are clear from the control arm. Again, do not allow the brake or ABS lines to become stretched or damaged during this process. **(photo 6)**
- 1g) Remove the 3 nuts securing the upper strut mount to the chassis.
- 1h) Mark the outboard side of the spring and top mount to assist with proper re-assembly and installation. Remove the strut from the chassis.

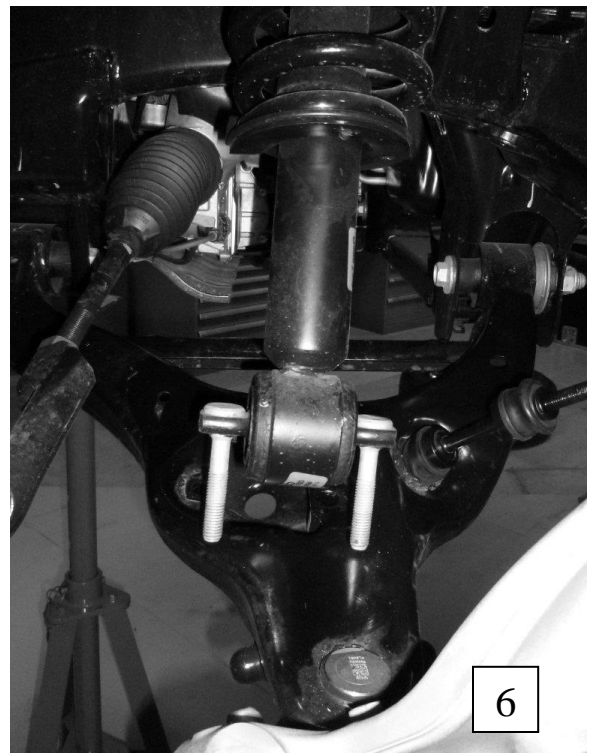
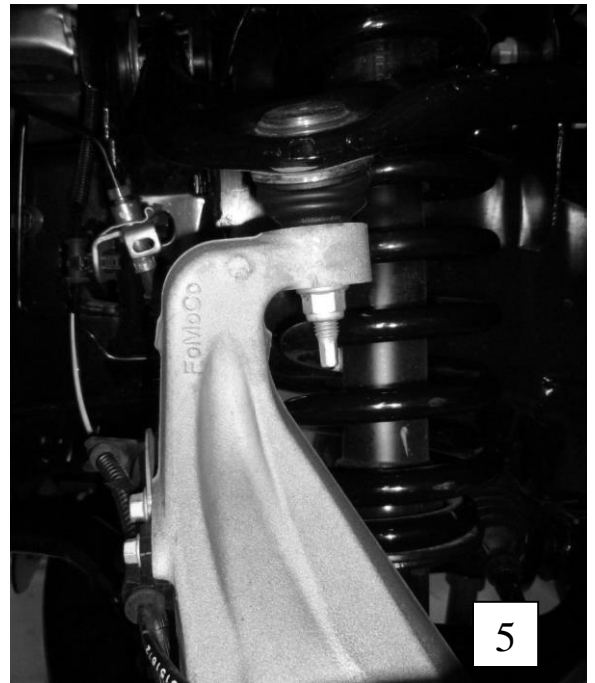

2. STRUT DISASSEMBLY

CAUTION! The coil springs is held in place under extreme compression. Belltech recommends the use of a heavy duty spring compression suitable for truck springs to perform this step. If unsure of your spring compressor capabilities, take this to a professional installer. Use caution during the following steps to avoid personal injury and/or damage to vehicle.

- 2a) Mount the entire spring/strut assembly in the spring compressor fixture. To ease the installation of the new strut, mark a white line down the center of each piece of the assembly for alignment purposes. Note the orientation of the upper mount relative to the bottom shock bar pin and studs.
- 2b) Compress the spring until the spring is no longer holding tension against the upper and lower spring perch.
- 2c) Hold the strut shaft from spinning and remove the top center nut from the strut. The shock will need to be supported as the nut is removed as it will fall if not supported. Remove the shock and bump stop from the assembly.

3. STRUT ASSEMBLY

3a) Refer to the chart below to determine the size and number of rings to install for the desired ride height.

Caution: The chart below is designed to use the Belltech 25007 with the stock vehicle spring. Combining the Belltech 25007 with a lowering spring will require adjusting the ring quantities to adjust for the lowered spring height. Belltech does not recommend total lowering of the vehicle beyond the lowest specification on this chart (3" total lowering) as the vehicle may not be able to be aligned and the performance of the shock may be greatly decreased.

ITEM DESCRIPTION	NUMBER OF RINGS INSTALLED ON STRUT								
	3" Lowering	2.5" Lowering	2" Lowering	1.5" Lowering	1" Lowering	.5" Lowering	OEM Height	.5" Lifting	1" Lifting
16mm (0.63") Ring	0	0	1	1	2	2	3	3	3
8mm (0.315") Ring	0	1	0	1	0	1	0	1	2

- 3b) Assemble the desired number of rings on to the Belltech Street Performance shock body. Slide the supplied Belltech spring perch on to the shock above the rings. See diagram for orientation.
- 3c) Install the supplied Belltech black plastic vent disk on to the shock. The vent disk will sit around the rod and rest on top of the shock body.
- 3d) Install the supplied Belltech bump stop on to the shock rod with the smaller end facing downward.
- 3e) Insert the assembled shock in to the compressed spring and upper spring perch. Secure the shock in to the top mount using the supplied nylon lock nut. Tighten lock nut to 33 ft/lb.
- 3f) Align the strut so the bar pin slopes downward to the outside of the vehicle. Use marking made during disassembly to ensure proper alignment. Uncompress the spring carefully ensuring proper seating in the upper and lower spring mounts.

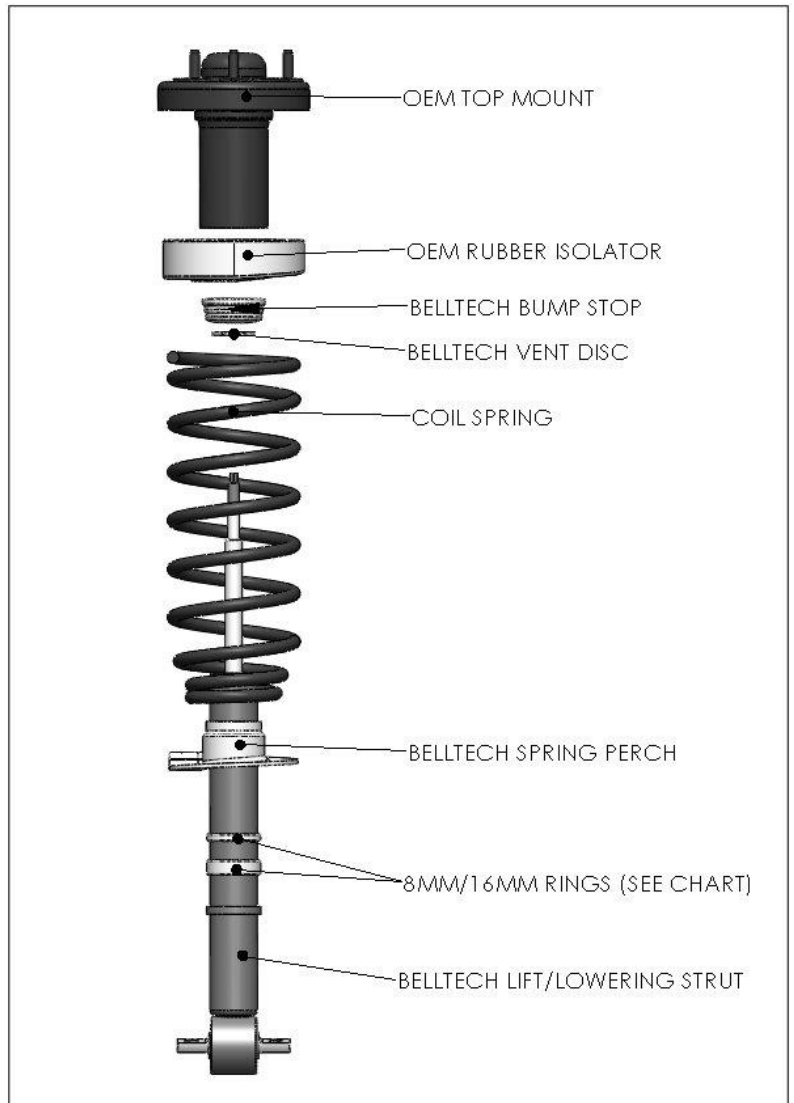

4. INSTALLING STRUT

- 4a) Install the top mount in to the chassis and secure with the original nuts. Torque nuts to factory specifications.
- 4b) Attach the lower strut mount to the lower control arm using the supplied Bolts washers and nylon lock nuts. Torque the supplied nuts to 60 ft/lbs.
- 4c) Attach the upper ball joint and tie rod ends to the steering knuckle. Torque nuts to factory specifications. Do not over tighten.
- 4d) Re-attach the upper end link to the sway bar and tighten to factory specification.
- 4e) Re-attach all brake and ABS lines using OEM bolts and re-attach plastic clips to their original location

5. ALIGNMENT MODIFICATION

This process is not normally needed for the Belltech 1" drop but is recommended when lowering more than 1". This process will allow for additional adjustment to obtain factory spec alignment. If lowering vehicle less than 2", please skip to step 6

- 5a) Remove both bolts securing the lower control arm to the chassis. **(photo 7)**
- 5b) Pull the lower control arm down below the chassis.
- 5c) Scribe a line 1/2" inward from the edge of the factory alignment slot in the chassis. This will need to be done to all 4 slots on each side of the vehicle. **(photo 8)**
- 5d) Use a die grinder with a carbide cutting tip to carefully elongate the slot towards the center of the vehicle. Do not elongate beyond the 1/2" outlined as this will allow the control arm to contact the frame.
- 5e) Remove any burrs after grinding and paint the exposed surfaces to prevent corrosion.
- 5f) Reinstall the lower control arms with OEM bolts and torque to factory specifications.

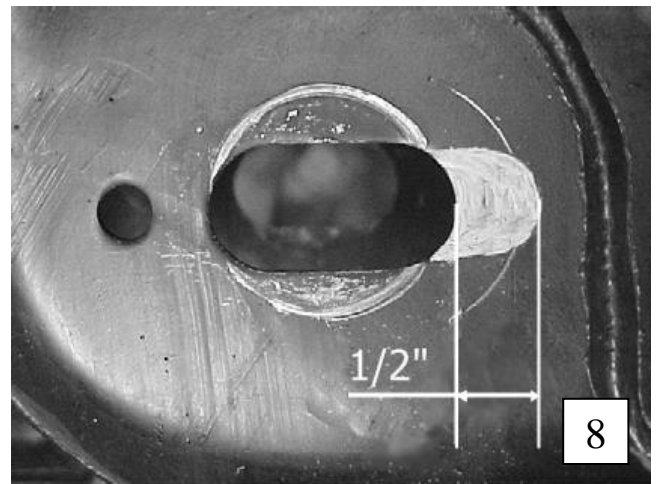
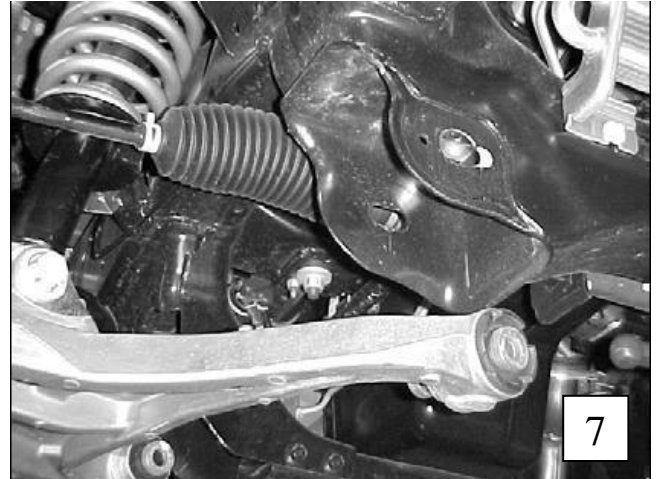

6. FINALIZING THE INSTALLATION

- 6a) All hardware being fastened to the vehicle's original fastening points should be torqued to the proper specifications. To prevent chassis damage, never over-torque the hardware.
- 6b) Check brake hoses and other components for any possible interference.
- 6c) Lift the vehicle and remove the support stands. Carefully lower the vehicle to the ground.
- 6d) **Front end alignment is required immediately following this installation.**
- 6e) Test-drive the vehicle in a remote location so that you can become accustomed to the revised driving characteristics and handling. Be aware that the vehicle will handle

- substantially different now that it has been modified.
- 6f) Installation is complete. Check all of the hardware and re-torque at intervals for the first 10, 100, 1000 miles.

Parts List: 25007

Part #	Description	Quantity
25007-001	SHOCK	1
112058	HHCS M14-1.5 X 70MM (LOWER STRUT MOUNT)	2
112298	NYLON LOCK NUT M14-1.5	2
110660	WASHER	2
25012-002	SPRING PERCH	1
25003-016	16MM SPACER	3
25003-008	8MM SPACER	2
4927-001	BUMP STOP	1
65210031	VENT DISK	1