



## 07-18 Jeep JK & JKU 4" Lift Kit

Thank you for being selective enough to choose our high-quality BELLTECH PRODUCT. We have spent many hours developing our line of products so that you will receive maximum performance with minimum difficulty during installation.

**Note:** Confirm that all of the hardware listed in the parts list is in the kit. **Do not** begin installation if any part is missing. Read the instructions thoroughly before starting this installation.

**Warning: DO NOT** work under a vehicle supported by only a jack. Place support stands securely under the vehicle in the manufacturer's specified locations unless otherwise instructed.

**Warning: DO NOT** drive the vehicle until all work has been completed and checked. Torque all hardware to specified values.

**Reminder:** Proper use of safety equipment and eye/face/hand protection is absolutely necessary when using these tools to perform procedures!

**Note:** It is beneficial to have an assistant available during installation.

### Exceptional Customer Experience Guarantee:

**STOP!** We strive for an exceptional experience for all of our valued customers. If, for any reason, you need assistance with your Belltech products, *please do not return the products to the store or website you purchased from.* Please call our dedicated experts at (1-800-445-3767) from 7 am PST to 5 pm PST.

### RECOMMENDED TOOLS:

- Properly rated floor jack and four (4) support stands
- Wheel chocks
- 1/2" drive torque wrench up to 200 ft/lbs range
- Standard and Metric socket wrench set
- Standard and Metric wrench set
- Tape measure
- Pliers
- Steel construction square
- Medium weight ball peen hammer/ center punch
- Marking pen
- Safety Glasses

# LIST OF ITEMS INCLUDED

## 07-17 JEEP JK 4WD 4" LIFT

10015B	FRONT STREET PERFORMANCE SHOCK	2
153201-118	FRONT COIL SPRING	2
153201-119	FRONT UPPER CONTROL ARMS	2
153201-121	FRONT LOWER CONTROL ARMS	2
153201-122	SWAYBAR ENDLINKS	4
153201-123	FRONT ADJUSTABLE TRACK BAR	1
153201-130	FRONT SS BRAKE LINE SET	1
2217RB	REAR STREET PERFORMANCE SHOCK	2
153201-210	REAR COIL SPRING	2
153201-211	REAR UPPER CONTROL ARMS	2
153201-212	REAR LOWER CONTROL ARMS	2
153201-215	REAR ADJUSTABLE TRACKBAR	1
153201-228	REAR COIL SPRING CORRECTION PLATES	2
153201-230	REAR SS BRAKE LINE SET	1
153201-229	<i>EXHAUST EXTENSION KIT</i>	1
153201-300	FRONT BRAKE LINE BRACKET	2

## EXHAUST EXTENSION KIT

153201-229L	EXHAUST EXTENSION LONG	1
153201-229S	EXHAUST EXTENSION SHORT	1
153201-229B	EXHAUST EXTENSION BOLT M8X1.25 - 90MM	4
153201-229W	EXHAUST EXTENSION WASHER M8	4

## HARDWARE KIT

110266	SCREW IN CABLE HOLDER	4
110267	BOLT M6X1.0 - 10MM FLANGE FULLY THREADED	4



## 1) KIT PREPARATION

- a) Before beginning, measure the hub to fender heights for your vehicle so you can compare the resulting height to the original. Measure vertically from the center of the wheel to the inner edge of the fender.

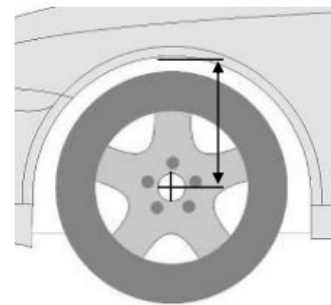

FR: \_\_\_\_\_ FL: \_\_\_\_\_ RR: \_\_\_\_\_ RL: \_\_\_\_\_

- b) Open the hardware kit and remove all contents. Refer to the parts list (Page 2) to verify that all parts are present.
- c) Park the vehicle on a smooth, level concrete or seasoned asphalt surface and activate the parking brake. Block the REAR wheels of the vehicle with appropriate wheel chocks, making sure the vehicle's transmission is in 1st gear (manual) or "Park" (automatic).

The vehicle must be properly supported during this installation to prevent personal injury and chassis damage. Make sure that the support stands are appropriately placed before performing the following procedures. We **DO NOT RECOMMEND** using wheel ramps while performing this installation.



## 2) FRONT INSTALLATION INSTRUCTIONS

- a) With the vehicle properly supported on jack stands, remove the front wheel using the appropriate socket. **(PHOTO 1)**
- b) Remove the front track bar using a 21mm socket. This hardware will be reused. **(PHOTO 2)**
- c) Remove the lower end links from the frame using a 18mm socket and wrench. Next, remove the top sway bar end link from the bar using a 19mm socket and 18mm wrench.
- d) Remove the upper and lower mounting hardware from the front shock absorber and uninstall from the vehicle. Lower bushing hardware will be utilized. **(PHOTO 3)**
- e) Loosen the lower control arm bolts using a 21mm socket and wrench. Do not remove the bolts and nuts as this allows the control arms to move freely. Do the same for the upper control arm using an 18mm socket and wrench. **(PHOTO 4)**



## 2) FRONT INSTALLATION INSTRUCTIONS CONTINUED

- g. Due to the lengths of the OEM brake lines, it is necessary for the lines to be removed from all the mounting locations. **(PHOTO 5)**
- h. Remove the spring by putting downward pressure against the axle and dislodging the spring from its seat. The OEM spring isolators will be reused in their original positions. Be sure to not over-extend any brake lines in the process. **(PHOTO 6)**
- i. With the axle fully supported, completely remove the previously loosened bolts for the four control arms.
- j. Using an 18mm wrench and socket, remove the bolts securing the upper control arm to the axle.
- k. The Belltech control arms provide a wide range of adjustment. Please refer to the suggested lengths as a starting point for this particular lift height. All measurements should be taken from eyelet to eyelet, meaning, center of bushing to center of spherical. Once the desired lengths are achieved, tighten the jam nut. **(PHOTO 7)**
- l. Grease all spherical eyelets and retighten all zerk fittings. All fittings should be facing upward to avoid any unwanted contact or obstruction.
- m. Using the OEM hardware, mount the control arms within the factory frame/axle locations. (The angled portion of the lower control arms should point toward the center of the vehicle to allow for maximum wheel and tire clearance.)
- n. Install the supplied front track bar into the factory location using the OEM hardware. The upper spherical includes eyelet spacers to mount within the frame clevis. Adjust the spherical eyelet to the center of its adjustment range to allow for the final lateral axle adjustment. **(PHOTO 8)**



*Approx. Upper Control Arm Length: 482mm / 19"*

*Approx. Lower Control Arm Length: 587mm / 23.125"*

*Approx. Track Bar Length: 831.85mm / 32.75"*

*Upper control arms: 120 ft-lbs*

*Lower control arms: 150 ft-lbs*

*Lower shock mount: 80 ft-lbs*

*Upper shock mount: 35 ft-lbs*

## 2) FRONT INSTALLATION INSTRUCTIONS CONTINUED

m) Loosen the stock brake line from the frame rail using a 12mm line wrench. Catch the brake fluid in a safe catch pan.

**Caution:** Brake fluid is highly corrosive and must be handled with proper safety equipment. Any spills or contact to paint must be cleaned up, immediately.

n) Completely remove the line from the frame rail by use of a 10mm wrench. Remove the line from the caliper using a 15mm wrench and install the supplied stainless steel lines and brackets. **(PHOTO 9)**

o) Install the new brake line bracket in the original bracket location by using the provided rubber isolators to attached the brake lines to the bracket.

p) Reattach the Stainless brake line at the caliper (do not forget the new crush washer) and brake line end. **(PHOTO 10)**

q) Install the front coil springs by seating the spring and isolator into the upper spring mount. Rotate the spring, so the lower and upper coils seat correctly. Raise the axle to hold the spring securely. **(PHOTO 11)**

r) Install the provided front shock by guiding the upper shock pin through the frame's shock mount. The two rubber bushings will sit above and below the frame mount. Tighten until the bushings begin to swell. **(PHOTO 11)**

s) Repeat steps "a" through "t" for the opposite sides.

t) Attach the lower shock eyelets to the axle and tighten them to 80 ft/lbs.

u) Ensure all hardware is appropriately tightened, then reinstall the front wheels and lower the front of the vehicle to the ground.

v) Assemble and install the new sway bar disconnects as shown. **(PHOTO 12)**

w) Attach the sway bar to the links, and tighten. The front installation is now complete.

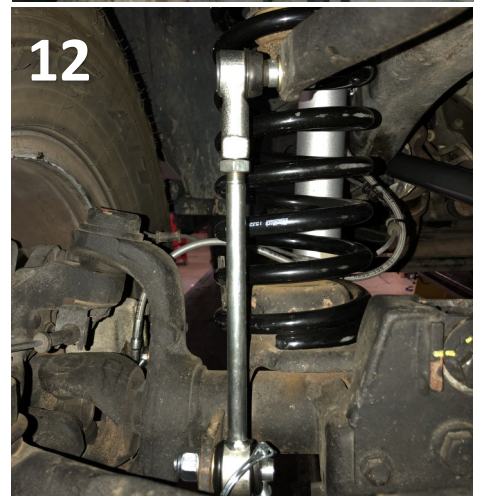

#### 4) REAR LIFT INSTALLATION

- a) Jack up the rear of the vehicle and set it on supporting jack stands. Be careful not to support the vehicle by the axle, as the axle needs to be able to move independently from the frame.
- b) Remove the wheels with the appropriate socket.
- c) Remove the rear track bar from the vehicle using a 21mm socket. Keep the hardware. **(PHOTO 13 & 14)**
- d) Use a 21mm socket to loosen, but not remove the hardware holding the lower control arms to the frame and axle. **(PHOTO 15)**
- e) Remove the factory sway bar end links using an 18mm socket and wrench on the lower end and an 18mm wrench and 19mm socket on the ball joint end.
- f) Unbolt the brake hose bracket using a 10mm wrench. The hardware will be reused later. **(PHOTO 16)**
- g) Unbolt and remove the rear shocks using an 18mm wrench and socket. **(PHOTO 17)**
- h) Be cautious and slowly lower the rear axle to remove the rear coil springs. Be careful to not overstretch any cables or wires. **(PHOTO 18)**
- i) Remove the upper control arms by removing the upper bolt using a 21mm wrench. Do not remove the flag nuts from their factory positions and keep all the hardware to reuse later. **(PHOTO 19)**

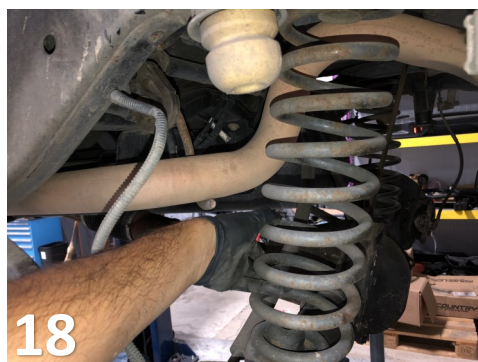
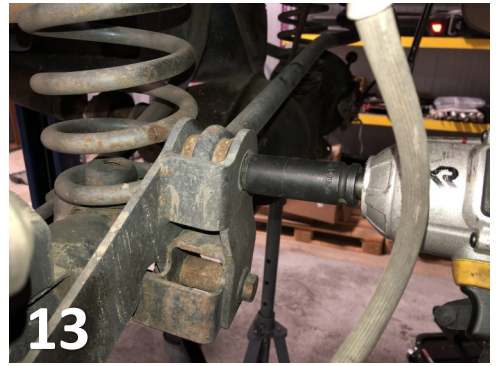

#### **4) REAR LIFT INSTRUCTION CONTINUED**

- g. Assemble the rear upper control arm in the same manner as the fronts. The Belltech control arms provide a wide range of adjustment. Please refer to the suggested lengths as a starting point for this particular lift height. All measurements should be taken from eyelet to eyelet, meaning, center of bushing to center of spherical. Tighten the jam nut once desired lengths are achieved. **(PHOTO 20)**
- h. Grease all spherical eyelets and retighten all zerk fittings. All fittings should be facing upward to avoid any unwanted contact or obstructions.
- j) Remove the bolts holding the lower control arm, using a 21mm socket at the axle and frame. Keep the factory hardware. Remove the lower control arm.
- k) Assemble the new, rear lower control arm, in the same manner as the fronts. Adjust to a suggested length of 530mm from eye to eye. Install the control arm with the Heim end attaching to the frame with the grease Zerk fitting pointing upwards to prevent damage. Use factory hardware and do not forget to tighten the jam nut. **(PHOTO 21 & 22)**
- l) Install the rear coil wedges in the lower spring seat, with the angled side down, as shown. **(PHOTO 23)**
- m) Install the new rear springs making sure to seat them properly. Raise the axle to ensure the springs no longer move freely. **(PHOTO 24)**

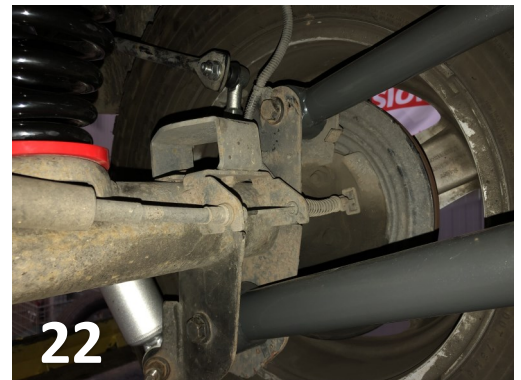
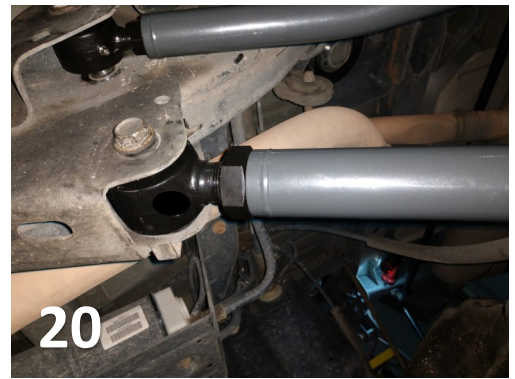

*Approx. Upper Control Arm Length: 460mm / 18.125"*

*Approx. Lower Control Arm Length: 530mm / 20.825"*

*Approx. Track Bar Length: 1050mm / 41.25"*

*Upper Control Arms: 120 ft-lbs*

*Lower Control Arms: 150 ft-lbs*

*Lower Shock Mount: 80 ft-lbs*

*Upper Shock Mount: 35ft-lbs*

#### **4) REAR LIFT INSTALLATION CONTINUED**

- o) Install the rear shocks using the factory hardware and lower the axles allowing the shocks to extend completely. Make sure that the springs do not move freely. **(PHOTO 25)**
- p) Assemble the rear track bar in the same manner as the front. Adjust to the suggested length. Install the track bar with the Heim end attaching to the frame with the greased zerck fitting pointing upwards to prevent damage. Use factory hardware, and do not forget to tighten the jam nut. **(PHOTO 26)**
- q) Loosen the stock brake line from the frame rail using a 12mm line wrench. Catch the brake fluid in a safe catch pan. **Caution:** Brake fluid is highly corrosive and should be handled with proper safety equipment. Any spills should be immediately cleaned up.
- r) Completely remove the line from the frame rail. Remove the line from the caliper using a 15mm wrench and install the supplied stainless steel lines and brackets. **(PHOTO 27)**
- s) Reattach the stainless brake line at the caliper (do not forget the new crush washers) and brake line end. **(PHOTO 28)**

**After installing both the front and rear brake line extensions. Please be sure to bleed the brakes of all air within the lines. Failure to do so will result in an inefficiently working hydraulic system.**

- t) To install the exhaust spacers, locate the connection between the headers and the mid-pipe. Remove the factory bolts connecting the exhaust pipes and insert the exhaust spacers between. The longer spacer is meant to be installed on the passenger side, while the short spacer is for the driver side gap. Use the supplied extended stainless bolts and washers to sandwich the spacers between the pipes. After the installation is complete, start the vehicle and check for any exhaust leaks. If exhaust leaks are found, adjust if needed. **(PHOTO 29)**
- u) Check all installed hardware, reattach the rear wheels, and lower the vehicle back down to the ground.
- v) Attach the supplied extended end links in the same way as the fronts. **(step v. pg.3)**
- w) Torque the lug nuts. The installation is now complete.





## 4) POST INSTALLATION

- a) **IMPORTANT:** The front and rear track must be adjusted to center the steering wheel before driving the vehicle. Adjusting the upper and lower control arms will directly affect pinion angle. Consult a shop or professional regarding adjustment, unwanted vibrations, or steering needs.
- b) Check that all components and fasteners have been properly installed, tightened, and torqued.
- c) Check brake hoses and other components for any possible interference or leaks.
- d) Torque lug nuts to OEM (factory) specifications.
- e) Test drive the vehicle in a remote location so you can become accustomed to the altered driving characteristics and handling. Be aware that the vehicle will handle substantially different, now that it has been modified.
- f) We recommend the vehicle be taken to a qualified wheel alignment facility to be realigned to factory specifications after completing the installation.
- g) Installation is complete. Check ALL of the hardware and re-torque at intervals for the first 10, 100, and 1000 miles.