

Ford Ranger

Set Part # 21028
Rev B 5-04



Step 1: Prior to Installation:

- A) **Fit:** Verify the fit of the flares to vehicle. (Some filing, sanding, or cutting may be necessary to ensure proper fit).
- B) **Painting:** (Optional) if paint is desired it must be done prior to installing flares on the vehicle clean outer surface with a good grade degreaser. **DO NOT USE LACQUER THINNER OR ENAMEL REDUCER AS A DEGREASER.** Wipe outer surface thoroughly with a tack rag prior to paint.
Paint flares using a high quality enamel, or polyurethane automotive paint. (Application of a primer coat is optional)
If painting edge trim (not recommended), use a flex additive.
- C) **Performance:** Using larger Tires may increase the area required to turn the vehicle. Some Tire/Rim combinations may require lowering bump stops and or installing steering stops to prevent tire from contacting flare.
- D) **Exhaust System:** Modifications may be necessary to maintain a minimum 4" clearance between flares and exhaust pipes. (Exhaust gases should not vent directly onto flares)
- E) **Metal Protection:** All exposed fasteners and bare metal should be treated with red oxide primer BEFORE installing flares.

TOOLS FOR EASY INSTALLATION

- Electric Drill
- 11/64" Drill Bit
- Pop Rivet Gun
- Sheet metal Cutting Tool (Hacksaw, Sabersaw, Air Chisel, Metal Nibbler, or Air Saw)
- Tape Measure
- Grease Pencil or Marking Pen
- Jack and Jack Stands (2)
- Red Oxide Primer
- Duct Tape and Spring Clips

FLARE INSTALLATION PROCEDURES

Step 2: Preparing the Work Area

- A) To work in the wheel well area, remove tire and any other obstructions using jack.
- B) Firmly support vehicle using jack stands.
- C) Remove factory flares (if any) from all wheel openings.

Step 3: Cutting Sheet Metal (Front) (See Illustrations #1 & #2)

- A) Remove all fasteners which connect the lower rear portion of the wheel well liner to the fender edge.
- B) Mark a point on the fender 2" from the rear corner of the wheel well. **See Illustration #1.**
- C) Place the correct flare on the fender and line up lower inside edge of flare with point marked in Step 3B. Each flare is embossed on the lower flat with letters indicating the correct wheel well location.

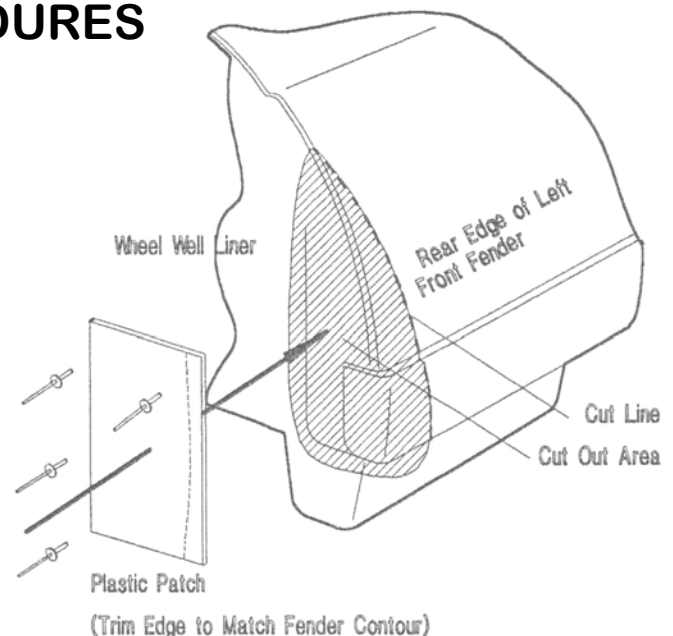

Illustration #1

(Example: RF indicates the flare which fits the right front fender location).

- D) Mark a line on the fender using the inside edge of the flare as a guide.
- E) Cut along the line drawn in Step 3D.
- F) Cut that portion of the wheel well liner immediately inside the fender cut. The liner cut out should measure approximately 4" wide by 8" high.
- G) Use a portion of the plastic patch material provided to fill in the area removed from the wheel well liner. Slotted rivets (6) should be used to secure the plastic patch material to the wheel well liner. **See Illustration #2.**

Note: The front wheel well area can be widened further by either trimming the trailing edge of the bumper or moving the entire bumper forward.

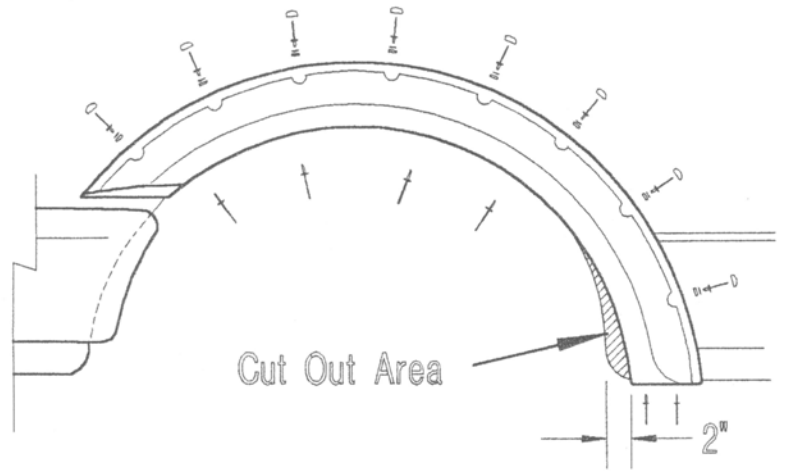

Illustration #2

**Step 4: Flare Attachment (Front)
(See Illustrations #2 & #3)**

- A) Position flare in the wheel well with gimp (rubber trim) between flare and fender. Trim bead should be tight against flare edge. Trim wrinkle can be reduced by cutting "V" notches along the flat. **See Illustration #3.** Make sure the inside lip and lower flat of each flare is correctly positioned against fender. Flares can be temporarily secured using tape and/or clips.
- B) Drill through flare, trim tape and fender using the supplied 11/64" bit at pocket locations. Secure flare to fender using rivets with cap bases. Press cap over cap base to finish.
- C) Secure the inside and lower flat of each flare to fender with rivets at the locations shown in **Illustration #2.**

Note: Rivets are not used in those areas where the fender has been cut out.

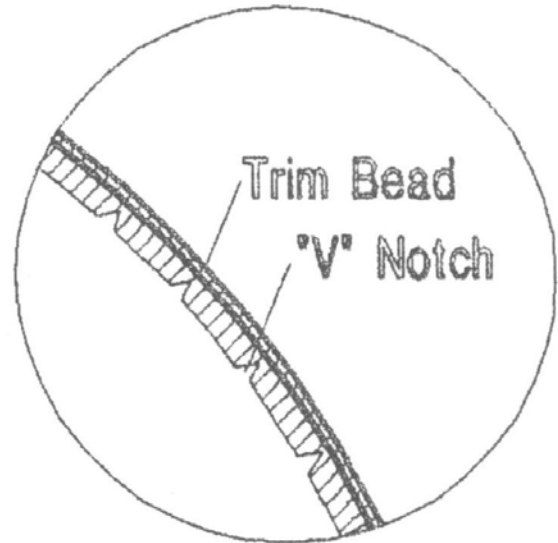

Illustration #3

**Step 5: Flare Attachment (Rear)
(See Illustration #3)**

Installation procedures for rear flares are generally the same as those described for front flares with the following exceptions:

- A) Rear flares do not require wheel well liner patching.
- B) Both leading and trailing edges of rear wheel wells are cut out.
- C) Both front and rear flat of each flare are secured with rivets. **See Illustration #4.**

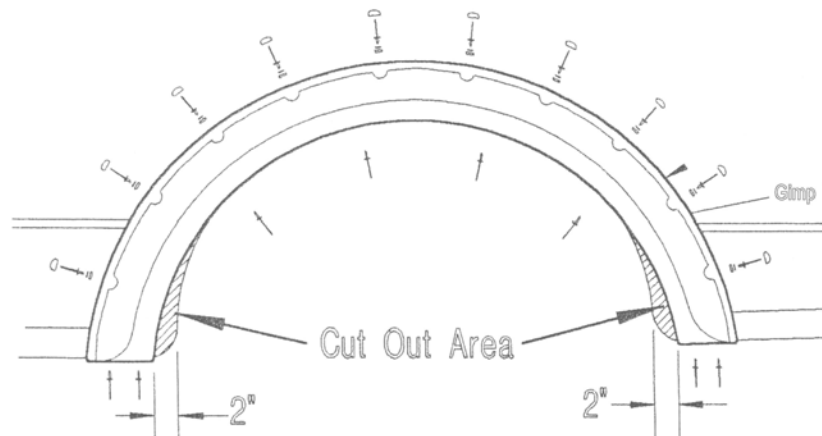

Illustration #4



INSTALLATION INSTRUCTIONS FOR **CUT-OUT FLARE GIMP**

Tools Required for Installation:

A. Nail or Awl

STEP 1: APPLICATION:

Follow flare installation instructions to the point of drilling first hole through sheet metal with the supplied bit. Sandwich gimp between flare and sheet metal; pierce a hole through gimp using pre-drilled hole in flare as a guide. Secure and continue as flare installation instructions direct. NOTE: make sure bulb of gimp is tight against top of flare when securing.

