



SPEED ELIMINATOR

Dodge Installation Instructions

**** NOTE: Only the 2004+ vehicles have the ability to adjust tire size.**

PLEASE READ ALL INSTRUCTIONS AND WARRANTY DISCLAIMER BEFORE INSTALLATION.

If you do not have the appropriate speed rated tires (> 130 mph) then do NOT install the unit.

2004-2005 Installation Instructions	Pages 2-4
2003 Installation Instructions	Pages 5-8
2000-2002 Installation Instructions	Pages 9-12

This kit now utilizes Posi-Taps™ by Posi-Products. Please refer to page 13 for usage instructions.

2004-2005 INSTALLATION INSTRUCTIONS

1. Disconnect both batteries before starting the installation.
2. Locate the ABS controller located on the driver side rear of the engine compartment. You will notice two sets of locking plugs leading into the ABS controller. Remove the largest plug (14 pins) for easy reference. You may need to remove a red locking pin to accomplish this. Please reference the table below to locate the appropriate wire to cut into.

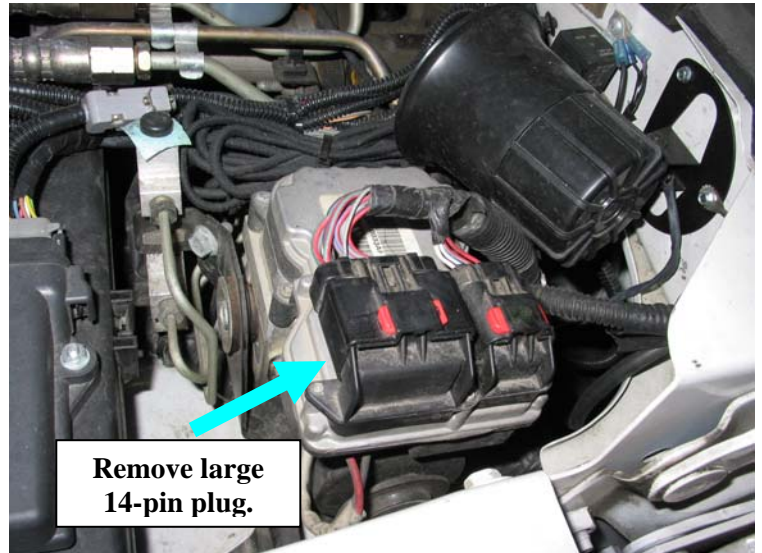
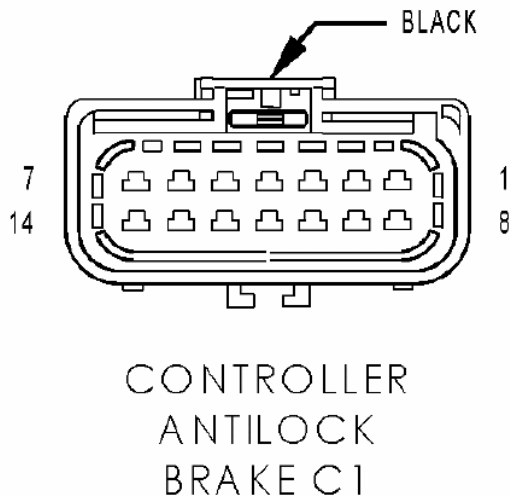

2004-2005

Wire	Wire Color	Pin
VSS Wire	Dark Green w/Yellow tracer	12
CCD BUS Wire	Not Applicable*	Not Applicable*

If for some reason the VSS wire does not exist or if you are having difficulty getting the speedometer to display the correct speed, please use the dark green w/white tracer wire located on pin 2 for the VSS wire.

3. You will need to cut the specific VSS wire (see table above). Be sure that when you cut these wires that you leave enough room as to attach the provided posi-lock connectors.
4. First attach the posi-lock connector to the cut wire at/closest to the ABS Controller plug, and then attach the supplied BLUE wire to the other end of the posi-lock connector. This blue wire should be connected to the VSS IN input of the Speed Eliminator module.

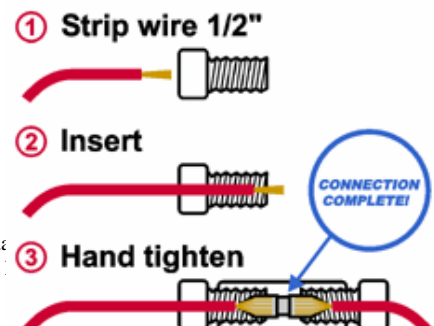

BD Engine Brake Inc.

Plant Address: Unit A10, 33733 King Rd, Abbotsford, BC, Canada
 U.S. Shipping Address: 88-446 Harrison St, Sumas, WA 98295 U.S. Mailing Address:
 Phone: 604-853-6096 Fax: 604-853-8749 Internet: www.bd-power.com

5. Now attach the remaining end (wiring harness end) of the VSS wire to another posi-lock. Now connect the remaining end of the posi-lock connector to the provided YELLOW wire. This yellow wire should be connected to the VSS OUT input of the Speed Eliminator.
6. Now slide the pair of wires (Blue & Yellow) that were provided in the kit (2004 only use one pair), through the firewall and into the cab. Cut these wires to length once you have determined the Speed Eliminator mounting point.
7. It is very important that the VSS wire closest to the ABS module is connected to VSS IN input on the Speed Eliminator module. The VSS OUT should be connected to the remaining side of the wire traveling into the wiring loom.
8. Finally, you will need to connect a 12 volt switched power source for the unit as well a solid clean ground. It is suggested that the Speed Eliminator be mounted underneath the dash.

A new feature of this unit is the ability to adjust for tire size. On the top of the module you will notice a small circular opening with a dial inside of it. Adjust this dial clockwise for larger tires or counter clockwise for smaller tire size. Straight up and down (12 o'clock position) is the stock tire size.

Common Adjustments



Stock



33" Tires



35" Tires

If you have stock tires or are not adjusting for tire size you must ensure that the arrow is exactly vertical.

2004-05 WIRING DIAGRAM

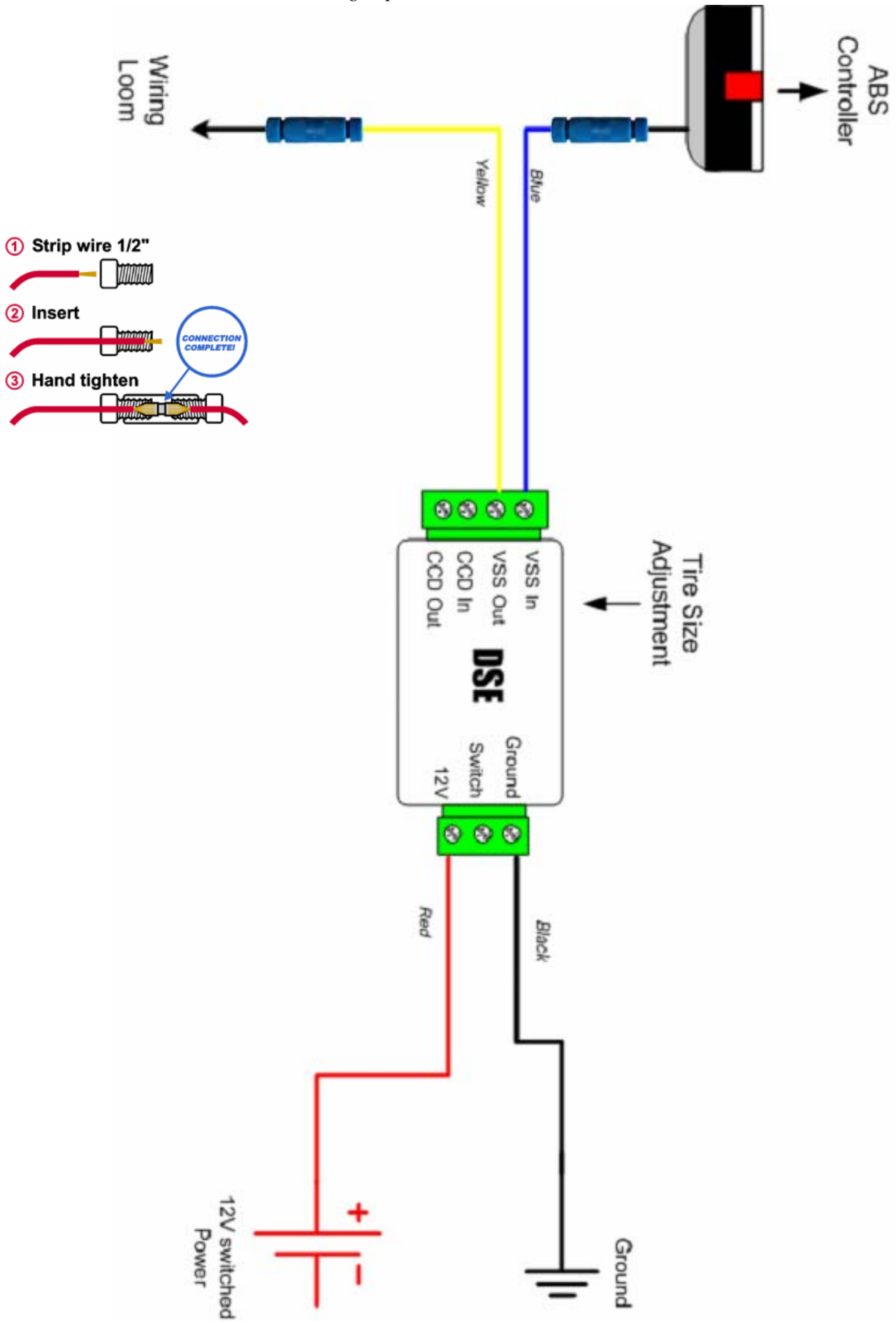

2003 INSTALLATION INSTRUCTIONS

Note that unfortunately the tire size calibration option does not work on 2003 vehicles, only 2004 models with the single PCM/ECM.

1. Disconnect both batteries before starting the installation.
2. Locate the wiring harness traveling down to the ECM on the side of the engine from the large wiring harness attached to the top of your firewall. This harness is enclosed in a plastic shield traveling from the ABS module (driver's side) to the PCM (passenger's side). You will need a small blade screwdriver to unhook the locking tabs of the plastic enclosure.

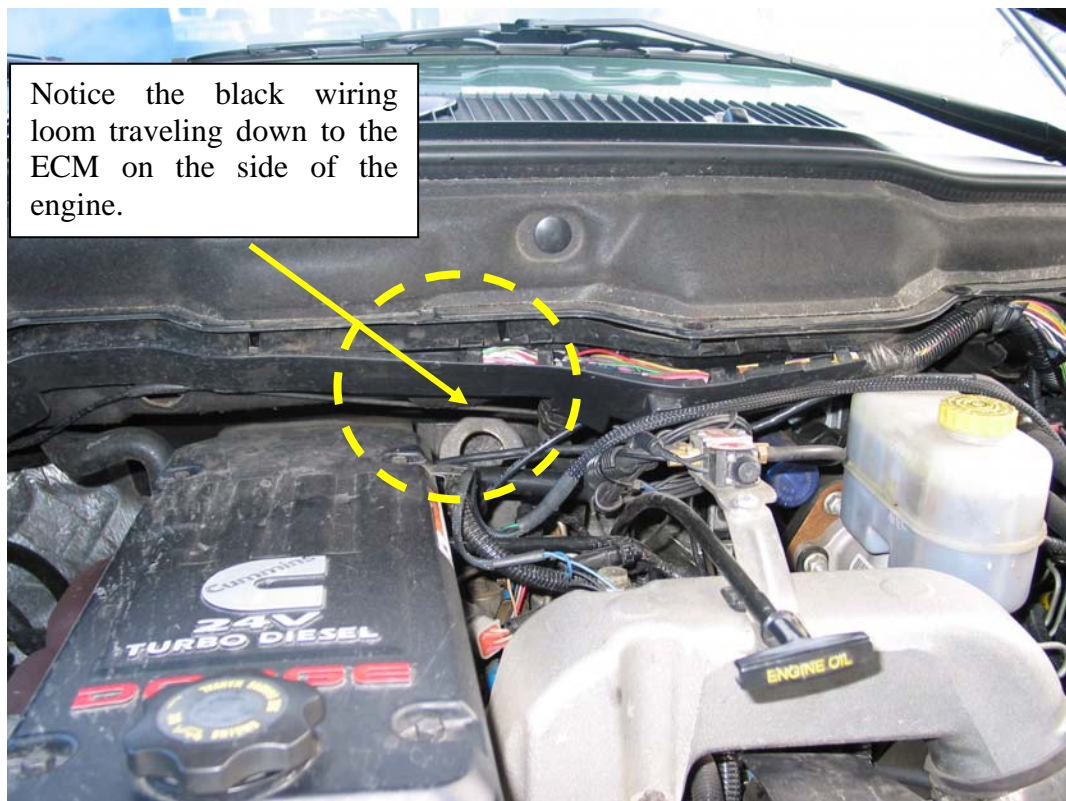

3. There will be a white w/orange tracer wire as well as a violet w/yellow tracer traveling down to the ECM inside this wiring harness. These are the wires you must cut, be sure to leave yourself enough room to crimp on connectors when cutting these wires.

Be very sure these wires travel down the ECM as there are a couple of white w/orange tracer wires mixed in the wiring harness. The actual white w/orange tracer wire actually splits into two coming from the ABS module, one side goes to the PCM and the other side goes down to the ECM.

BD Engine Brake Inc.

Plant Address: Unit A10, 33733 King Rd, Abbotsford, BC, Canada V2S 7M9

U.S. Shipping Address: 88-446 Harrison St, Sumas, WA 98295 U.S. Mailing Address: P.O. Box 231, Sumas, WA 98295

Phone: 604-853-6096 Fax: 604-853-8749 Internet: www.bd-power.com

4. Now choose a good mounting location underneath the dash for the Speed Eliminator, you can use double side tap or zap straps to hold the unit. It is also need that you route 12V switch power and a clean ground to the unit.
5. With the supplied 2 pairs of wire you will need to route them from the mounting location of the Speed Eliminator under the dash through and along the firewall to the location of the cut wires.
6. Now the **VSS OUT** of Speed Eliminator must be connected to the white w/orange tracer wire traveling down **TO THE ECM.** This is by far the most important connection.
7. The VSS IN should then be connected to remaining cut side of the white/orange tracer wire that travels back to the ABS module and the PCM.
8. Connect the Speed Eliminator's CCD IN to one side of the violet w/yellow tracer wire and connect the CCD OUT to the other side. This connection can be made in any matter it does not matter which side is connected to the CCD IN or the CCD OUT. Just ensure that the wires do indeed travel down to the ECM.
9. You will now need to find a mounting location for the RACE mode activation switch (not standard transmissions). Use the switched power source from the module and route that into the switch. You can also use the same ground as the module. See the wiring diagram for complete details. Race mode should be active with the switch in the up or orange position.
10. When the switch is in the ON position (lighted) it should provide 12 volts to the SWITCH terminal of the Speed Eliminator unit and 0 Volts in the OFF position.

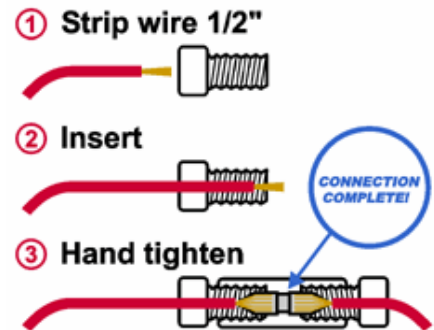

If you are having trouble locating this wire you can find these wires on Connector #2 of the Cummins ECM on the side of the engine.

2003 Cummins ECM Connector # 2

Wire	Wire Color	
VSS Wire	White w/Orange tracer	Connector #2 Pin 11
CCD BUS Wire	Violet w/Yellow tracer	Connector #2 Pin 28

Even though the tire size calibration does not work for this year of vehicle be sure that the adjustment knob located on the side of the Speed Eliminator is **exactly vertical.**



Stock

2003 WIRING DIAGRAM

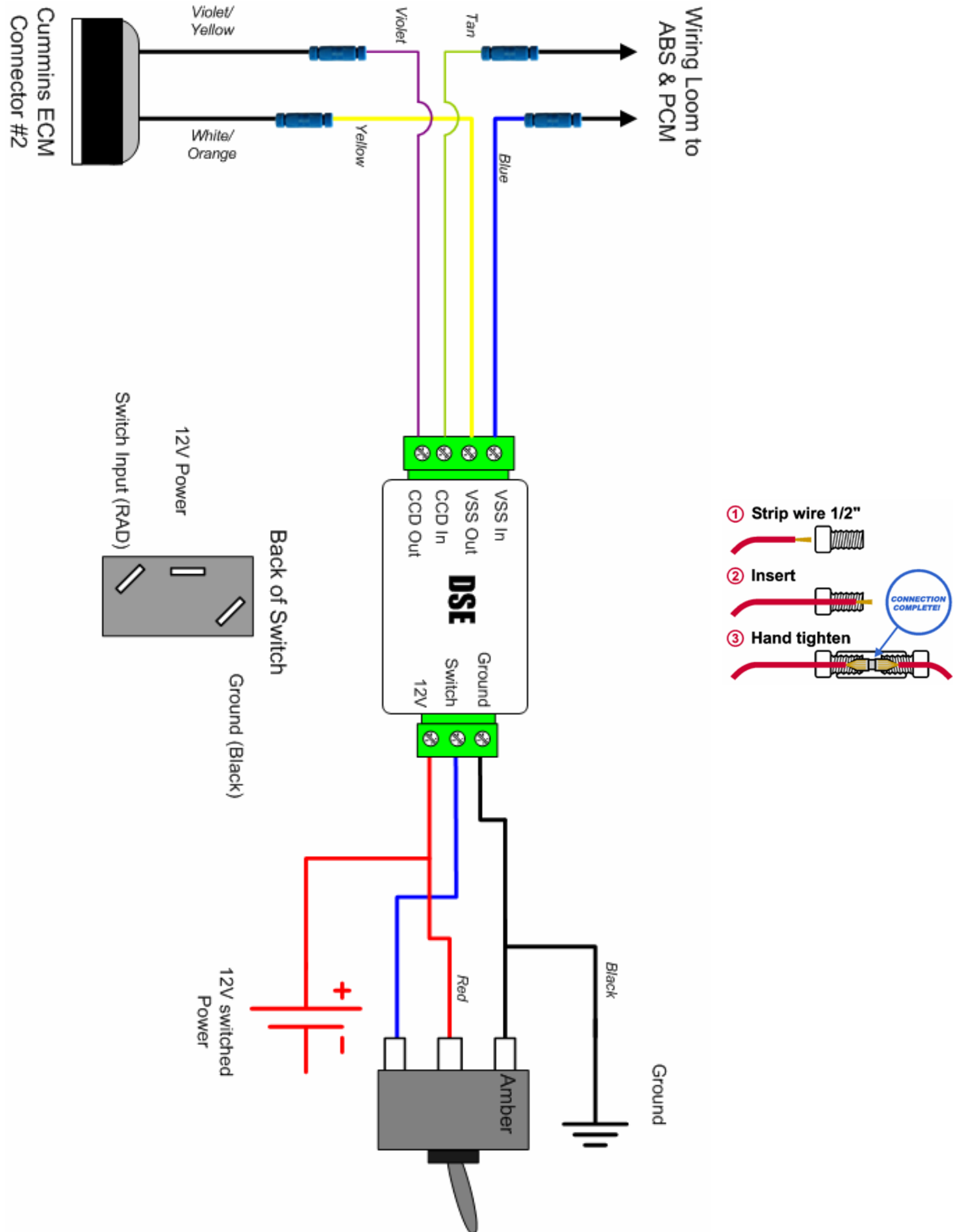

BD Engine Brake Inc.

Plant Address: Unit A10, 33733 King Rd, Abbotsford, BC, Canada V2S 7M9

U.S. Shipping Address: 88-446 Harrison St, Sumas, WA 98295 U.S. Mailing Address: P.O. Box 231, Sumas, WA 98295

Phone: 604-853-6096 Fax: 604-853-8749 Internet: www.bd-power.com

To activate full race mode, flick the toggle switch to the ON position.

Note: In full race mode the instrument cluster will not function and a check engine light will be displayed. Once the mode is switched back to the stock switch position everything should be normal. Also keep in mind that if the switch is not hooked up, the unit will still remove the stock speed limiter.

In full race mode (switch position 2) the truck does not want the rev, you have the orange wires hooked up incorrectly, just switch them around. The rest of the instructions are pretty straightforward. Just follow the wiring diagram.

The purpose of the full race mode is to eliminate torque management from degrading your acceleration in 1st and 2nd gear. Also note that the speedometer may stop displaying any speed over 90 mph due to the function of eliminating the speed limit.

2000-2002 INSTALLATION INSTRUCTIONS

Note that unfortunately the tire size calibration option does not work on 2000-2002 vehicles, only 2004 models with the single PCM/ECM.

1. Disconnect both batteries before starting the installation.
2. Locate the wiring harness traveling down to the ECM on the side of the engine from the large wiring traveling along the top of your firewall. Attached to this wiring harness are two locking connectors: one white and one black. It is located just above engine valve cover on the passenger side.

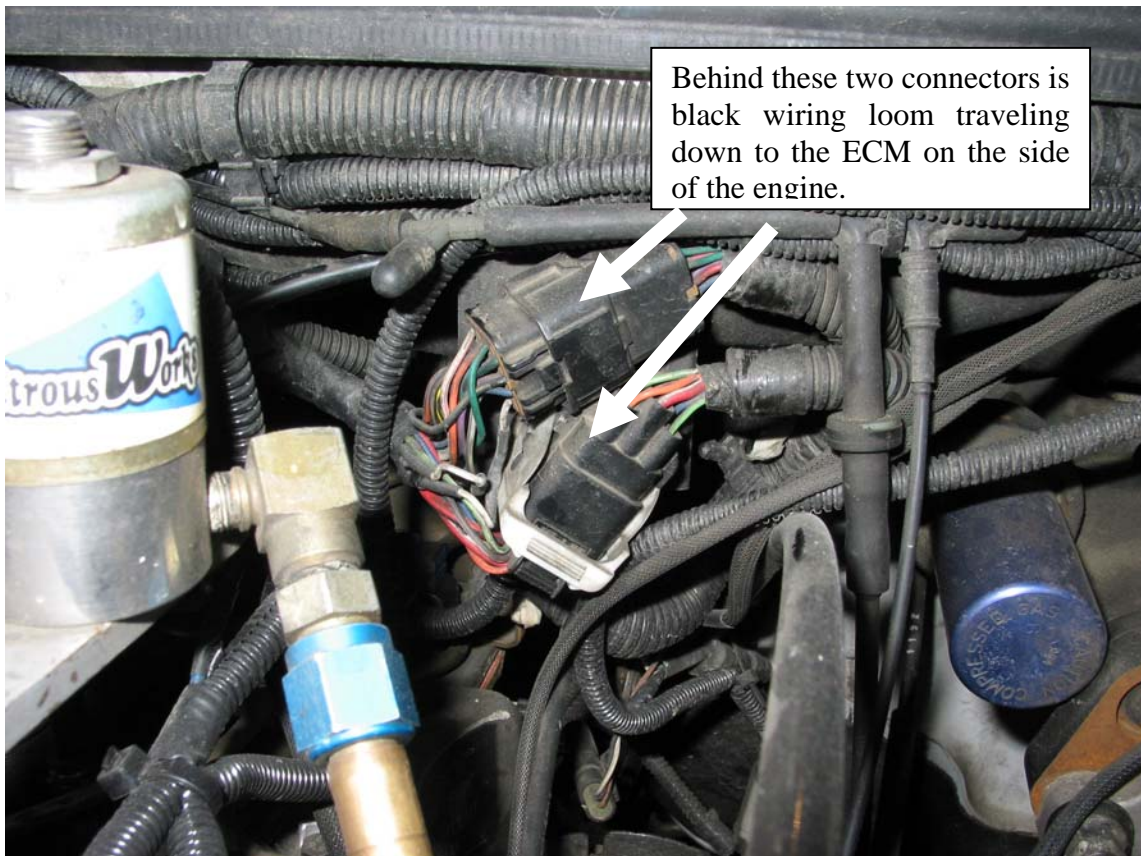

3. There will be a white w/orange tracer wire located in the wiring harness connector with the white locking tab on it. This is the VSS wire you will need to cut. Located on the other black wiring harness connector will be a white w/black tracer wire. This wire is the CCD BUS wire you will need to cut.
4. You will now need to mount the Speed Eliminator underneath the dash. Tie wraps have been provided to fix the module in place.
5. Route the 2 pairs (Blue and Yellow, Tan and Violet) of supplied wire from the new location of the Speed Eliminator through and along the firewall next to the loom towards to the two black and white connectors described earlier.

BD Engine Brake Inc.

Plant Address: Unit A10, 33733 King Rd, Abbotsford, BC, Canada V2S 7M9

U.S. Shipping Address: 88-446 Harrison St, Sumas, WA 98295 U.S. Mailing Address: P.O. Box 231, Sumas, WA 98295

Phone: 604-853-6096 Fax: 604-853-8749 Internet: www.bd-power.com

6. You will now need to connect the VSS OUT of the Speed Eliminator (Yellow wire) to the white w/orange tracer wire traveling down the wire loom towards to ECM on the side of the engine. You have to make sure that this wire travels down to the ECM and not to PCM located on the passenger side of the vehicle.

7. Now connect the VSS IN of the Speed Eliminator (Blue wire) to the other side of the cut white w/orange tracer wire that travels to the PCM located on the passenger side of the vehicle.

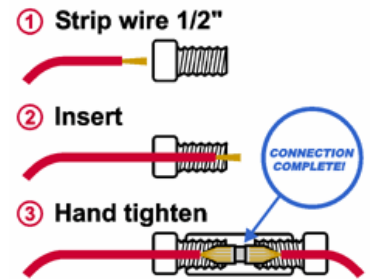

8. Now connected the CCD IN and CCD OUT to either sides of the cut white w/black tracer wire. It does not matter which side goes wire, just be sure that a good solid connection is made.

9. You will now need to find a mounting location for the RACE mode activation switch (not standard transmissions). Also needed is a switched power source for the Speed Eliminator module and the toggle switch. As well you will need to find a clean ground for both the switch and the module. Finally you will need to route the activation wire from the switch to the module. Race mode should be active with the switch in the up or orange position.

10. When the switch is in the ON position (lighted) it should provide 12 volts to the SWITCH terminal of the Speed Eliminator unit and 0 Volts in the OFF position.

If you are having trouble locating these wires you can find these wires on the Cummins ECM on the side of the engine.

2000-2002 Cummins ECM Connector		
Wire	Wire Color	
VSS Wire	White w/Orange tracer	Connector #2 Pin 11
CCD BUS Wire	White/Black tracer	Connector #1 Pin 5

Even though the tire size calibration does not work for this year of vehicle be sure that the adjustment knob located on the side of the Speed Eliminator is **exactly vertical**.



Stock

2000-2002 WIRING DIAGRAM

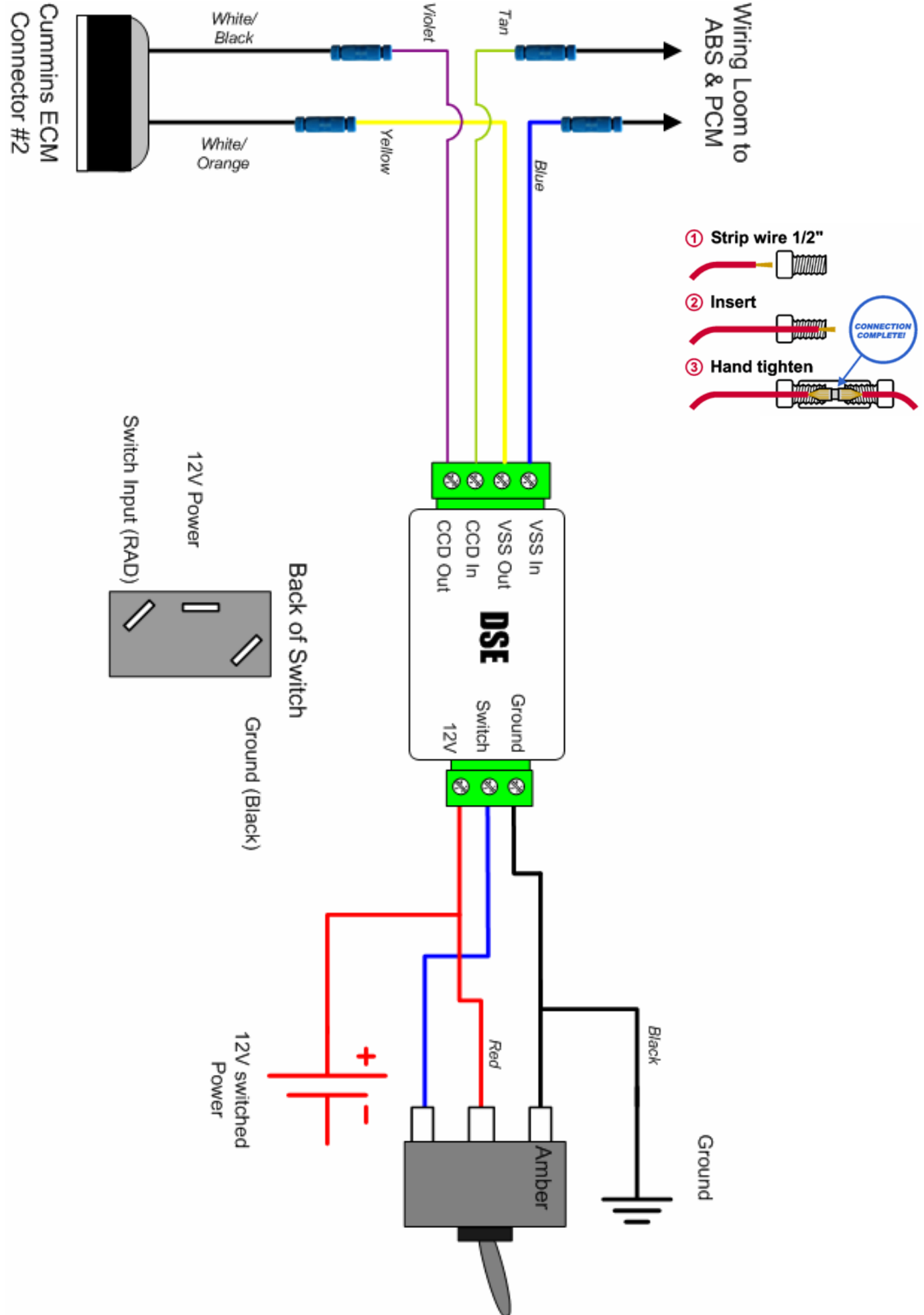

BD Engine Brake Inc.

Plant Address: Unit A10, 33733 King Rd, Abbotsford, BC, Canada V2S 7M9

U.S. Shipping Address: 88-446 Harrison St, Sumas, WA 98295 U.S. Mailing Address: P.O. Box 231, Sumas, WA 98295

Phone: 604-853-6096 Fax: 604-853-8749 Internet: www.bd-power.com

To activate full race mode, flick the toggle switch to the ON position.

Note: In full race mode the instrument cluster will not function and a check engine light will be displayed. Once the mode is switched back to the stock switch position everything should be normal. Also keep in mind that if the switch is not hooked up, the unit will still remove the stock speed limiter.

In full race mode (switch position 2) the truck does not want the rev, you have the orange wires hooked up incorrectly, just switch them around. The rest of the instructions are straightforward; just follow the wiring diagram.

The purpose of the full race mode is to eliminate torque management from degrading your acceleration in 1st and 2nd gear. Also note that the speedometer may stop displaying any speed over 90 mph due to the function of eliminating the speed limiter.

NOTES ON CONNECTORS

The kit includes a number of Posi-Tap™ connectors (Gray/Black/Green) to tap onto OEM wiring. It is important to select the correct color of connector so that it matches the gauge of the OEM wire that it is being installed on. Using the incorrect connector could cause an inadequate connection and/or the OEM wire could be severed.

OEM Wire	Posi-Tap™ Color
18-22ga	Gray
12-18ga	Black
10-12ga	Green

Though these connectors offer a quicker installation, the best option would be to solder the wires and isolate the joints with heat shrink or liquid electrical tape. Proper soldering techniques should be used to ensure adequate connections.

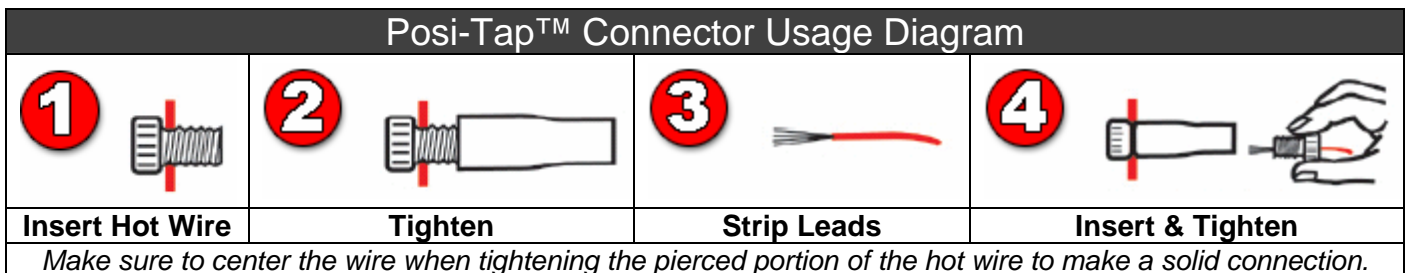

If you have any technical difficulties, concerns, comments, or complaints, please phone our Technical Support hotline at (800) 887-5030 between 8:30am-5:00pm PST (Pacific Standard Time) Monday to Friday, or post a message on the BD Discussion Forums located at:

<http://forum.bd-power.com/>



WELCOME TO OUR CLUB!

BD DISCUSSION FORUMS



Visit our Internet forums at <http://www.dieselperformance.com> and share your comments or technical support questions with some of the industry's leading experts in the diesel field.

BD Engine Brake Inc.

Plant Address: Unit A10, 33733 King Rd, Abbotsford, BC, Canada V2S 7M9

U.S. Shipping Address: 88-446 Harrison St, Sumas, WA 98295 U.S. Mailing Address: P.O. Box 231, Sumas, WA 98295

Phone: 604-853-6096 Fax: 604-853-8749 Internet: www.bd-power.com

DISCLAIMER OF LIABILITY

Other than as expressly set forth herein, BD ENGINE BRAKE, Inc. (hereafter collectively, "SELLER"), together with its distributors, jobbers and dealers shall in no way be responsible for the PRODUCT'S proper use and service. In no event shall SELLER be liable for any special, incidental, indirect or consequential damages of any kind or nature, whether or not BUYER was advised of the possibility of damage, arising or resulting from the use or performance of the PRODUCT, and BUYER hereby waives any and all such claims.

BUYER acknowledges that he/she/it is not relying on SELLER'S skill or judgment to select or furnish goods suitable for any particular purpose and that SELLER has no liability that will extend beyond the scope of the limited warranty contained herein, and BUYER hereby waives all remedies or liabilities, expressed or implied, arising by operation of law or otherwise, (including, without limitation, any obligations of SELLER with respect to fitness for any particular purpose; merchantability; and special, incidental, indirect or consequential damages) or whether or not occasioned by SELLER'S negligence.

SELLER disclaims any warranty and expressly disclaims any liability for personal injury or damages related to BUYER'S use of the PRODUCT. BUYER acknowledges and agrees that the disclaimer of any liability for personal injury is a material term for this agreement and BUYER agrees to indemnify SELLER and hold SELLER harmless from any claim related to the PRODUCT and its use or performance. Under no circumstances will SELLER be liable for any damages, liabilities, costs or expenses incurred as a result of by reason of the use, performance or sale of the PRODUCT, including, without limitation, any damages, liabilities, costs or expenses incurred by reason of BUYER'S negligence related to those uses of the PRODUCT as a result of the removal of the speed limiter.

SELLER assumes no liability regarding the improper installation or misapplication of the PRODUCT. It is the installer's responsibility to check for proper installation, and, if in doubt, contact the manufacturer.

LIMITATION OF WARRANTY

SELLER hereby provides the following limited warranty as to description, quality, merchantability, fitness for any product's purpose, productiveness, or any other matter of SELLER'S product sold herewith. The SELLER shall be in no way responsible for the product's open use and service and the BUYER hereby waives all rights other than those expressly written herein. This Warranty shall not be extended or varied except by a written instrument signed by SELLER and BUYER.

The Warranty is Limited to one (1) year from the date of sale and limited solely to the parts contained within the product's kit. All products that are in question of Warranty must be returned shipping prepaid to the SELLER and must be accompanied by a dated proof of purchase receipt. All Warranty claims are subject to approval by BD ENGINE BRAKE, Inc.

Under no circumstances shall the SELLER be liable for any labor charged or travel time incurred in diagnosis for defects, removal, or reinstallation of this product, or any other contingent expenses.

Under no circumstances will the SELLER be liable for any damage or expenses insured by reason of the use or sale of any such equipment.

IN THE EVENT THAT THE BUYER DOES NOT AGREE WITH THIS AGREEMENT: THE BUYER MAY PROMPTLY RETURN THIS PRODUCT, IN A NEW AND UNUSED CONDITION, WITH A DATED PROOF OF PURCHASE, TO THE PLACE OF PURCHASE WITHIN THIRTY (30) DAYS FROM DATE OF PURCHASE FOR A FULL REFUND. THE INSTALLATION OF THIS PRODUCT INDICATES THAT THE BUYER HAS READ AND UNDERSTANDS THIS AGREEMENT AND ACCEPTS ITS TERMS AND CONDITIONS.

BD Engine Brake Inc.

Plant Address: Unit A10, 33733 King Rd, Abbotsford, BC, Canada V2S 7M9

U.S. Shipping Address: 88-446 Harrison St, Sumas, WA 98295 U.S. Mailing Address: P.O. Box 231, Sumas, WA 98295

Phone: 604-853-6096 Fax: 604-853-8749 Internet: www.bd-power.com