



Installation Manual

1968-1970 MOPAR B-BODY FACTORY AIR

DOCUMENT #1-2066FA

©2013 ClassicAutoAir / 6.13 vsA





Congratulations...

You have just purchased the highest quality, best performing A/C system ever designed for your Mopar.

To obtain the high level of performance and dependability our systems are known for, please pay close attention to the following instructions. Our installation steps and procedures are derived from a long history of research and development and the combined experience achieved thru thousands of successful installations (and feedback from customers like you). Please remember that our #1 goal is that you'll have a successful installation and a system that performs at a very high level for many years to come.

Before starting, read the instructions carefully, from beginning to end, and follow the proper sequence. On the next page you'll find a safety and general checklist that you should read before starting your installation.

Again, thank you from our entire staff.



Check List, Pre-Installation:

- Before beginning the installation check the shipping box for the correct components. YOUR BOXED UNIT INCLUDES A LIST OF MAJOR COMPONENTS AND A LIST OF BAGGED PARTS. We have a 5 stage check process to make sure you have everything you'll need.
- If your vehicle has been or is being modified, some procedures will need to be adjusted to fit your particular application.**
- A basic cleaning of the engine compartment and interior before beginning will make things go more smoothly.
- Check condition of engine mounts. Excessive engine movement can damage hoses to A/C and/or heater.
- Before starting, check vehicle interior electrical functions (interior lights, radio, horn, etc). Make a note of anything that does not work as it's supposed to. During the installation you might find the opportunity to repair or upgrade non-working or out of date components. When you're ready to start the installation, **DISCONNECT THE BATTERY FIRST.**
- Drain the radiator. Retain the coolant and reuse, or dispose of properly.
- SAFETY FIRST: Wear eye protection while drilling/cutting, deburr sharp edges, and never get in a hurry or force a part.
- Tools: Your installation only requires the basic tools everyone has in their garage, nothing exotic or specific to A/C or Heat equipment.

Procedures, During Installation:

- Fittings: Use one or two drops of mineral oil (supplied with your kit) on ALL rubber o-rings, threads and where o-rings seat in fittings. Do not use thread tape or sealants.
- Measure twice (or more), cut once
- Should you have any technical questions, or feel you have defective components (or missing items), call us immediately, we will be glad to assist you. Our toll-free number is listed on every page, we're here to help!**

YOU CAN NOW BEGIN THE INSTALLATION...

A Basic Overview of Automotive A/C...

- 1 Evaporator with Blower Fan** In order to remove the heat from the air in the vehicle, the A/C evaporator allows the refrigerant to absorb the heat from the air passing over it. The blower fan moves cool air out into the car interior.
- 2 Compressor** The compressor pumps and circulates the refrigerant through the system.
- 3 Condenser** The condenser is a heat exchanger mounted at the front of the vehicle. Heat drawn out of the interior of the car is expelled here.
- 4 Receiver/Drier** The drier not only dries refrigerant, it also filters the refrigerant and stores it under certain operating conditions.
- 5 High Pressure Switch** A pressure switch is used to shut down the system if high or low pressure is detected, basically it acts as a safety switch.

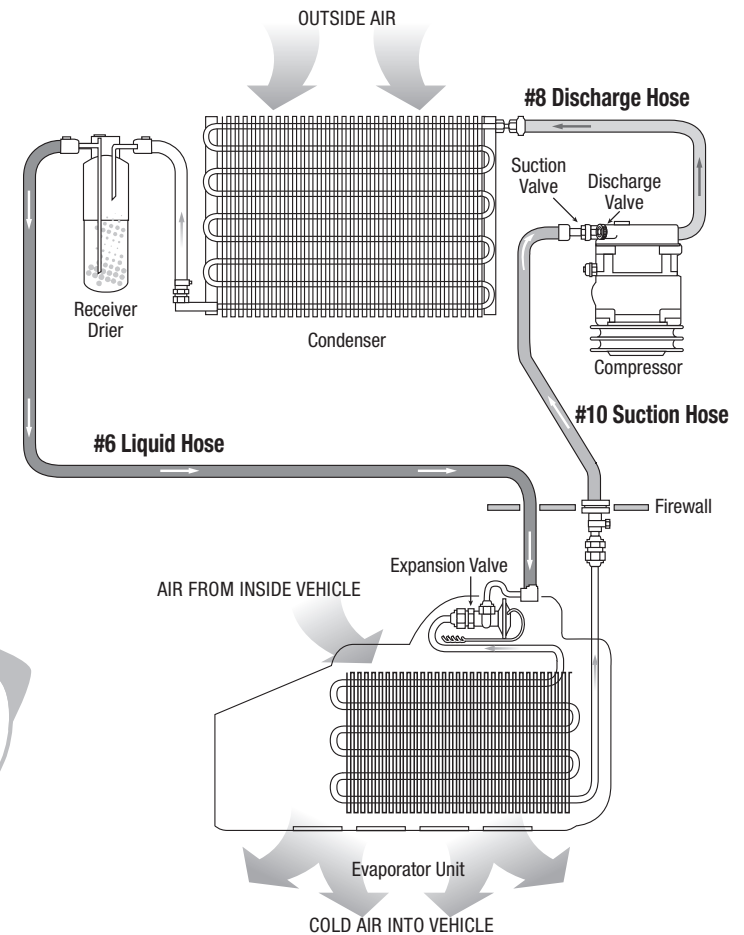
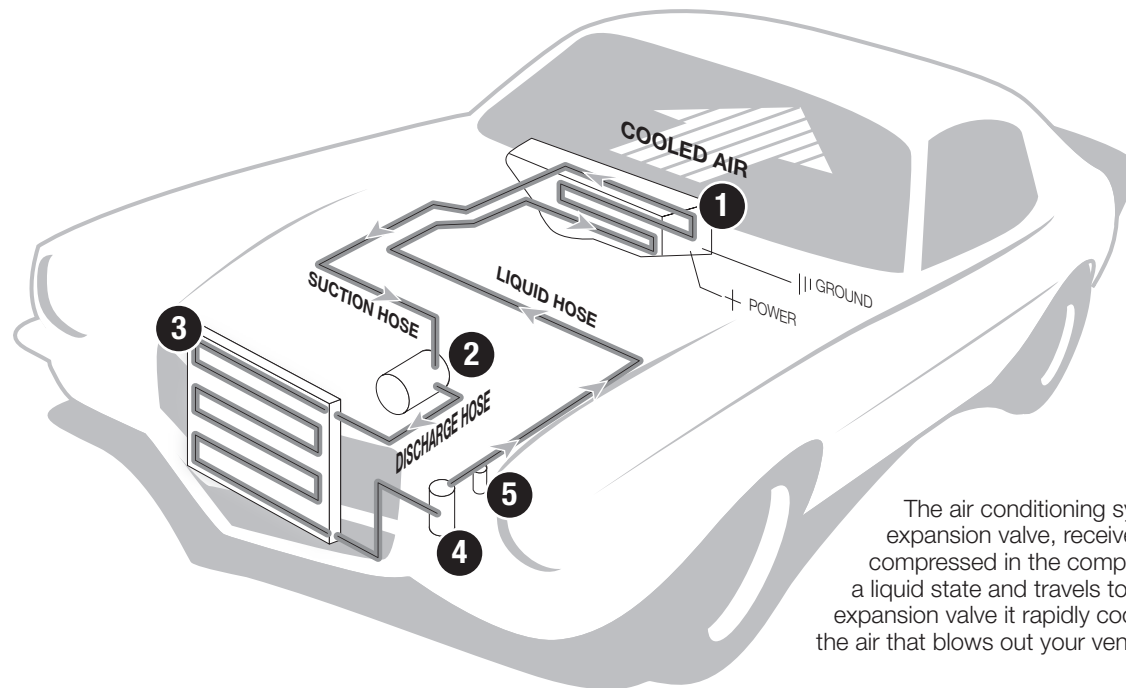

The air conditioning system in your car is comprised of a compressor, condenser, expansion valve, receiver/drier, and evaporator. Refrigerant (also known as Freon) is compressed in the compressor and turns into a gas. In the condenser, this gas is cooled to a liquid state and travels to the expansion valve. As the liquid refrigerant goes through the expansion valve it rapidly cools in the evaporator. A fan blows over the evaporator and cools the air that blows out your vents. The receiver-drier separates gas and liquid.



CONTROL & OPERATING INSTRUCTIONS

Your new **Perfect Fit-Elite** system offers complete comfort capabilities in virtually every driving condition. This includes temperature control in all of the modes. This system also provides the ability to blend the air between Face, Heat, and Defrost modes simultaneously. To illustrate the various ways you can adjust the airflow direction and temperature - we've provided these handy illustrations and chart to show exactly how you can adjust your **Perfect Fit-Elite** for maximum comfort...

NOTE: When the TEMP lever is in the FULL FOWARD (the coldest setting) position the compressor is ON, no matter what position the DASH / FLR lever is in (think of it as a compressor-override function)

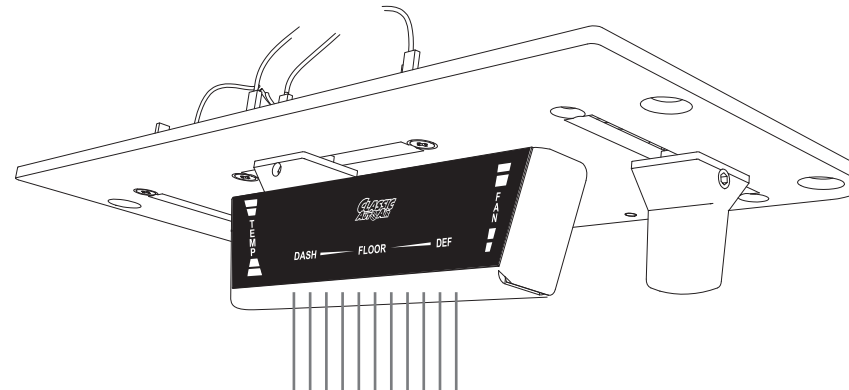

The FAN switch works like the OEM switch, the far FORWARD position is OFF (all power to the system is OFF in this position)

There are 11 levels of adjustment within the range of the DASH/FLOOR lever

| | DASH | | FLOOR | | | | | | | DEF | |
|------------------|---------------|-----------------------|-----------------------|-----------------------|-----------------------|------------|--------------------------|--------------------------|--------------------------|--------------------------|--------------|
| Lever Position | 1 | 2 | 3 | 4 | 5 | 6 | 7 | 8 | 9 | 10 | 11 |
| Distribution | Face A/C 100% | Face 80% Floor 20% | Face 60% Floor 40% | Face 40% Floor 60% | Face 20% Floor 80% | Floor 100% | Floor 80% Defrost 20% | Floor 60% Defrost 40% | Floor 40% Defrost 60% | Floor 20% Defrost 80% | Defrost 100% |
| Compressor State | ON | | | | | | | | | | ON |

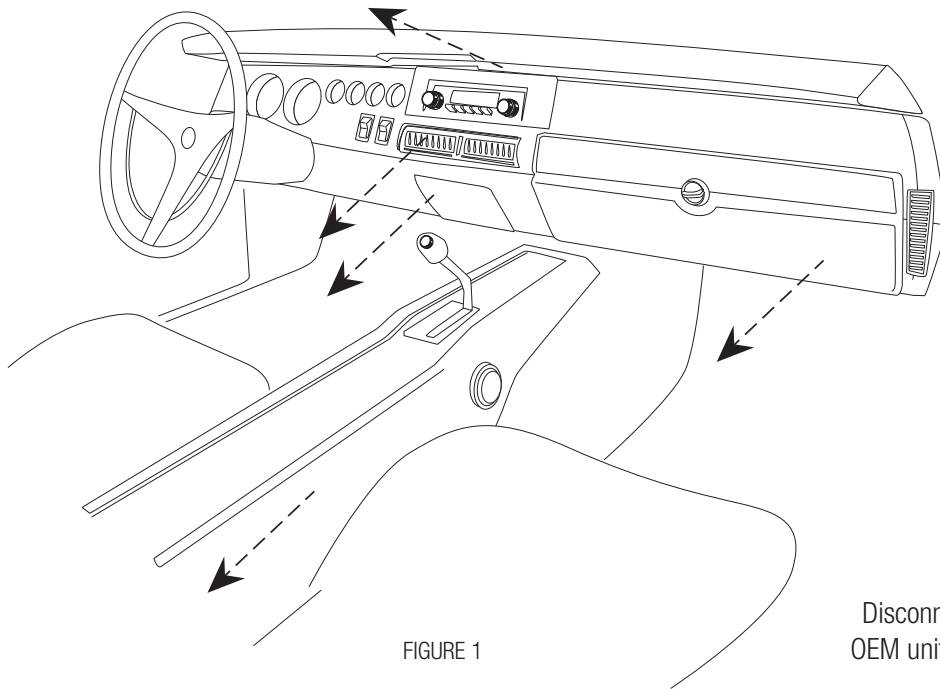

FIGURE 1

Remove Glove box, Glovebox door, Ashtray, and Radio, and OEM A/C controls (we provide our new D.E.R. controls). and set them aside for reinstall later (see figure 1). *Note: If vehicle is equipped with a console, remove entire console and set aside.*



When retaining parts it's a good idea to store parts in a zip lock bag, labeled with info where the parts came from and what size/type of tool is needed to reinstall. Cleaning the parts before you need to reinstall them is a good idea too.

Disconnect the electrical harness from the OEM assembly. Remove front support brace from the OEM unit (see figure 2). Retain the hardware (we will be providing a new support brace).

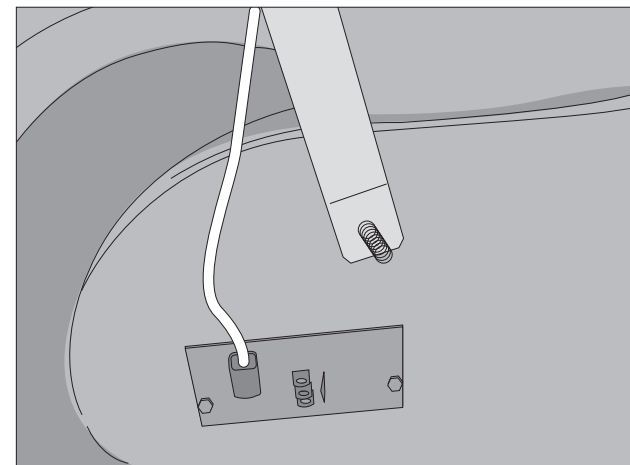
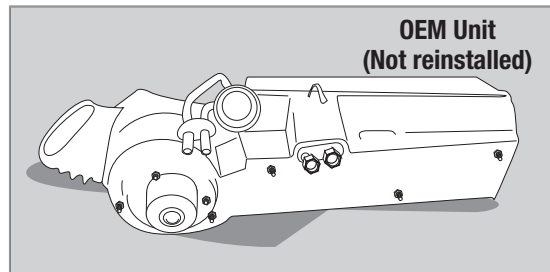
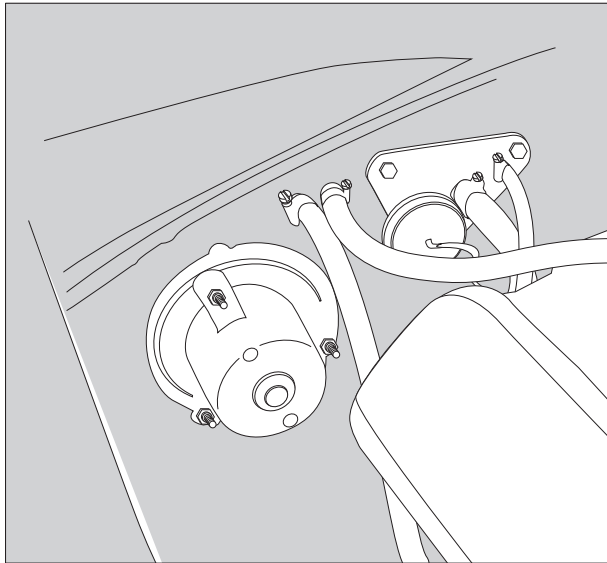

FIGURE 2



Remove all the factory duct hoses and discard. Unhook the cable to the OEM heater valve and push the tout thru the firewall. Remove all 5 nuts that hold OEM A/C unit to firewall (see figure 3). At this point the OEM A/C unit should be free and you can remove from the vehicle. Nothing on the OEM unit will be reused on this installation.

DRAIN COOLANT FROM RADIATOR. Store safely to reuse or recycle accordingly. Cut heater hose approximately 1" from firewall (see figure 5B). Also, to prevent forgetting to refill the coolant when the installation is completed, do not put the cap back into place - instead put the cap to the side and cover radiator hole with a clean rag or something similar.

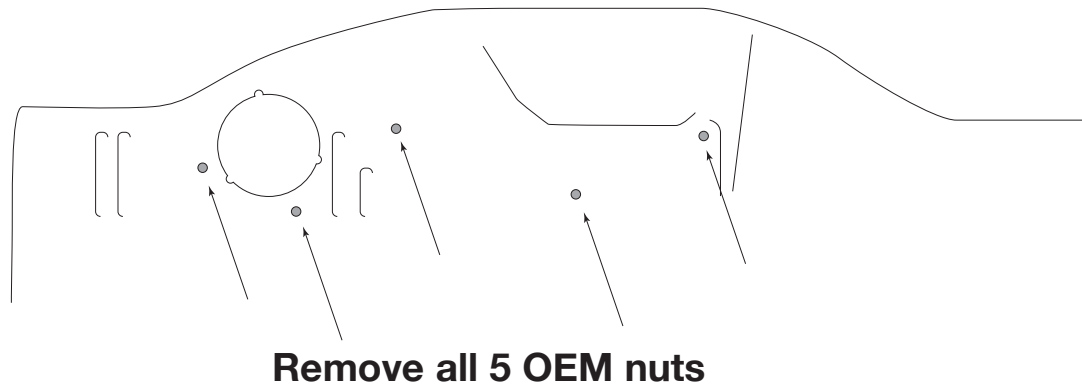
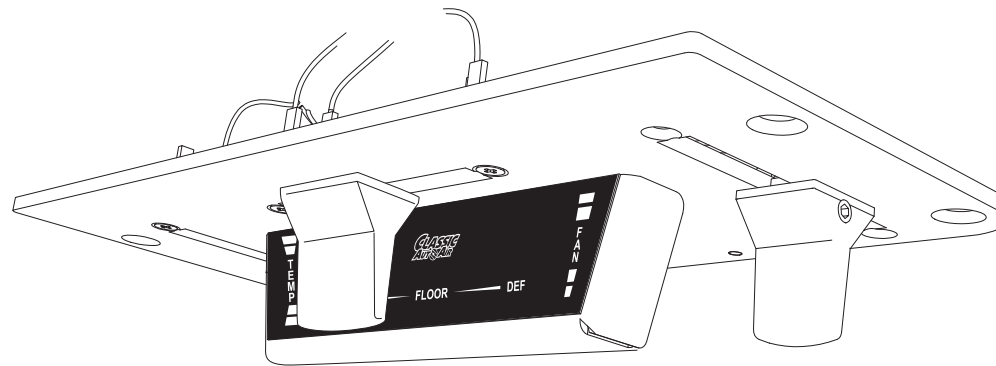

FIGURE 3

THESE ARE THE PARTS YOU WILL FIND IN BAG KIT A

You will use all of these parts and hardware during the next series of installation steps.



*D.E.R. Controller
PN# 16-3066*

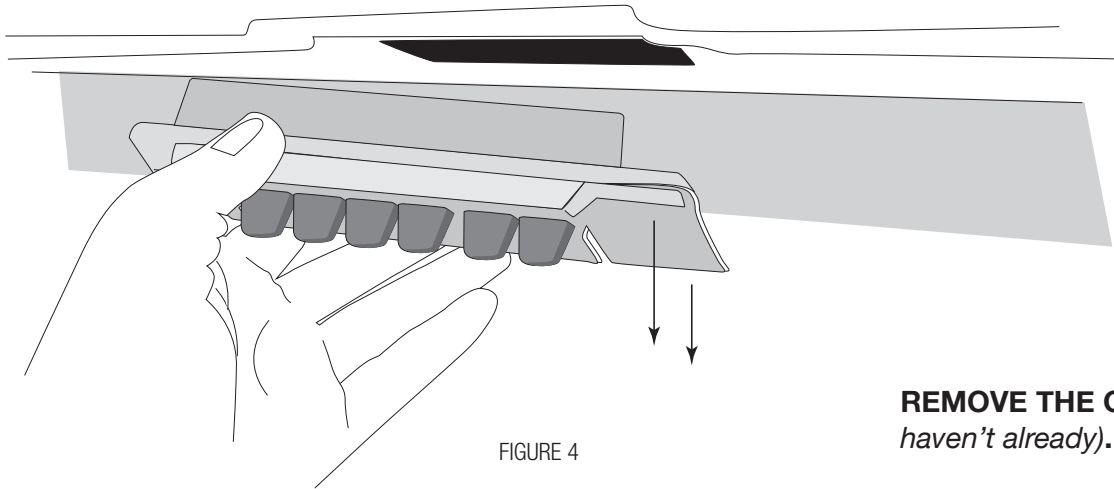
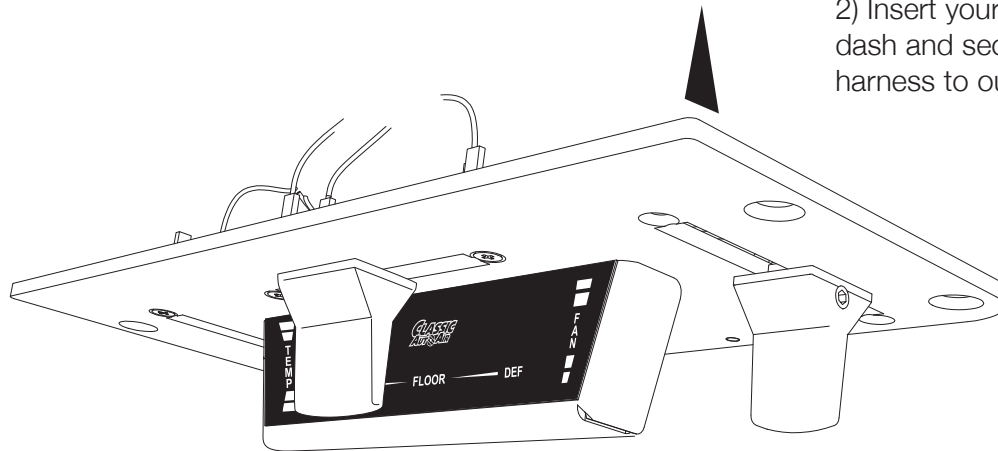

FIGURE 4

REMOVE THE OEM CONTROL HEAD FROM THE DASH (*if you haven't already*).

- 1) There are four screws that hold the OEM control unit in the dash. Remove the screws and set the assembly aside (see figure 4).
- 2) Insert your new D.E.R. controller (feeding the wires in first) into the dash and secure with the OEM screws. You'll connect the controller harness to our ECU a bit later.



THESE ARE THE PARTS YOU WILL FIND IN BAG KIT B

You will use all of these parts and hardware during the next series of installation steps.

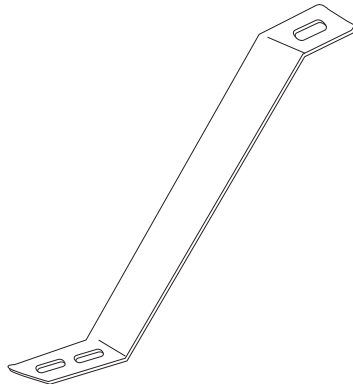

Evap Support Bracket
PN# 0066-21

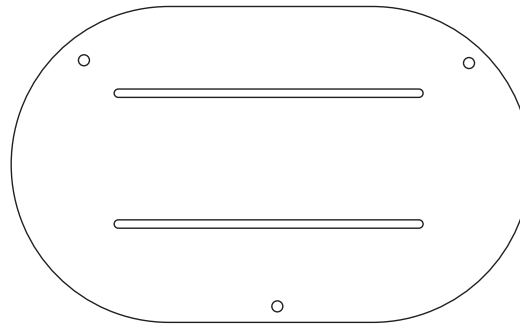

Fresh Air Inlet Block Off
PN# 10-1066-2

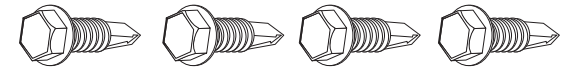

Four #10 - 16 x 3/4" Tek Screws



Two #10 - x 3/8" Phillips Screws

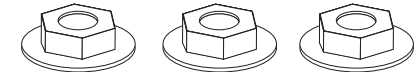

Three #10 - 10 x 5/8" Flange Nuts
PN#25CNFLZ/S



Two #8 - x 3/8" Phillips Screws

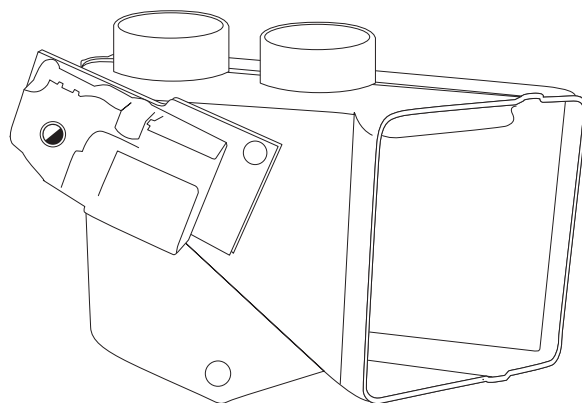

Defrost/Heat Duct Assembly
PN# 2-2025-2

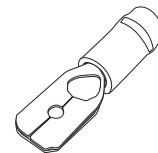

One Male Spade Connector



Two Fender Washers
PN #0113-3

Illustrations NOT shown actual size

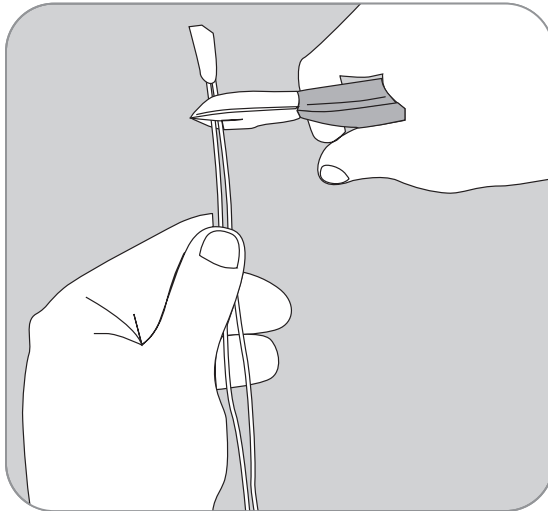

FIGURE 5

Locate the original wiring harness that supplied power to the OEM unit and cut them close to their end. On the OEM power supply wire attach a 1/4" insulated male spade connector (see figure 5).

Within the OEM fuse box upgrade the factory HEATER fuse with a 20 amp fuse (VERY IMPORTANT).

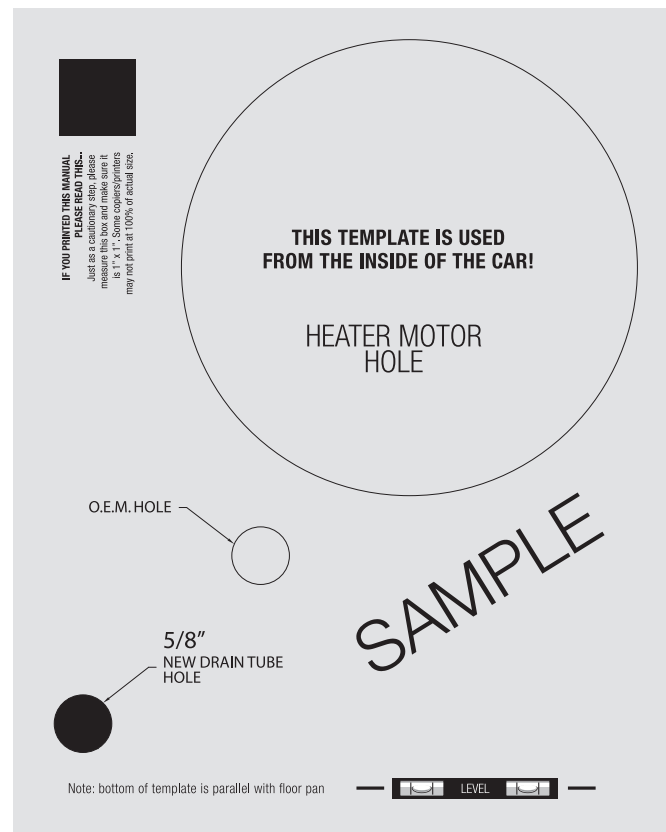

FIGURE 6

Locate behind dash and on firewall the hole that previously mounted the OEM unit.

Drill a 5/8" dia. hole for the drain tube as shown using the template we've provided (see figure 6).

All preliminary modifications to the vehicle are complete.

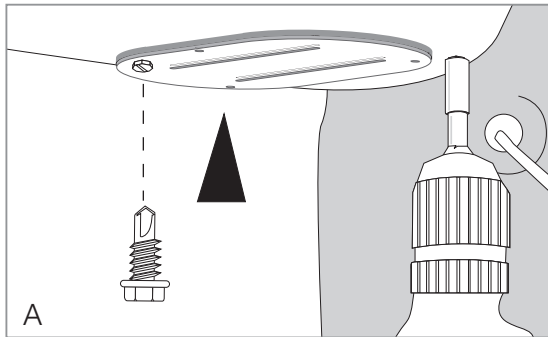

FIGURE 7

Locate the fresh Air inlet block off. Install over hole in inlet cowl as shown. Attach with three #10 - 16 x 3/4" Tek Screws (see figure 7).

Remove evaporator unit from box and place on a clean work bench.

Locate defrost / heat duct assembly and attach to the evaporator using two #10 - 10 x 5/8" Phillips screws (see figure 8). **NOTE: Be sure that the s-clips are pushed over rear flange on evaporator.**

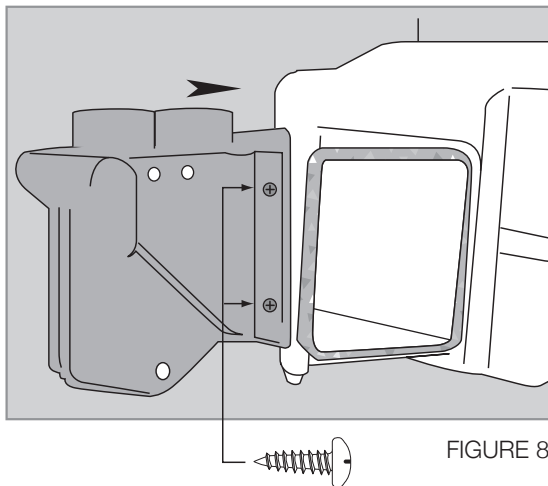
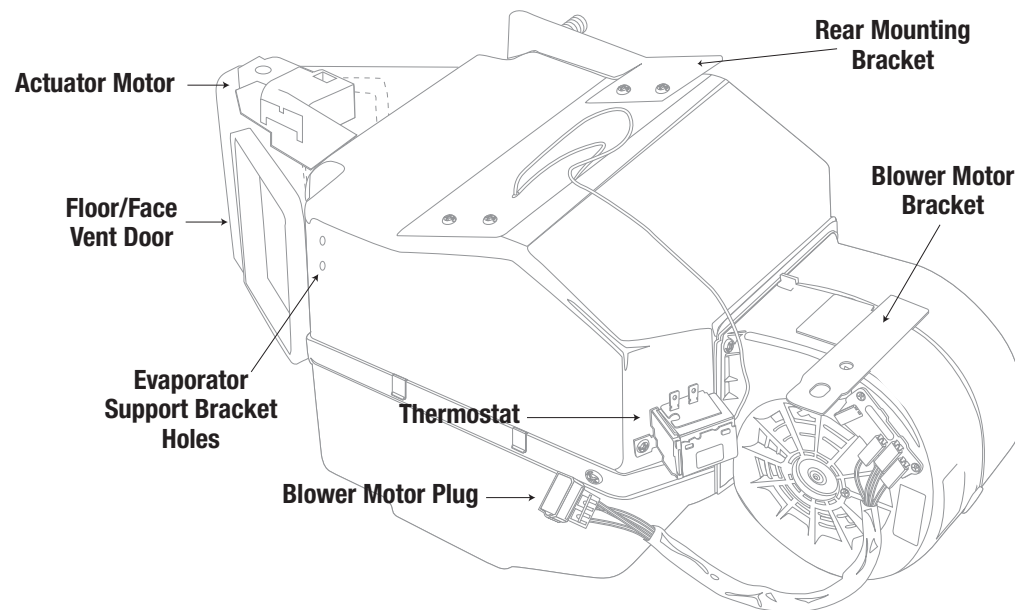
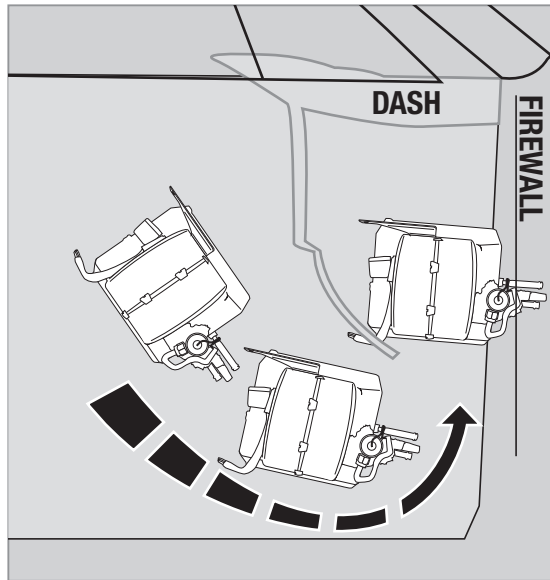

FIGURE 8

Take a minute to familiarize yourself with the evaporator unit:





Installing the complete evaporator unit under the dash will go much easier with the help of a friend. One person can take the unit within the car and “roll” up and under the dash while the other person can be ready at the firewall area with one or more of the included flange washers and nuts (the OEM hole are oversized and will require both a washer and flange nut for each). On back side of the evaporator is a mounting bracket with two studs. These studs will protrude thru the OEM holes (see figure 9).

Next, attach the bracket located on the blower motor to the underside of the cowling with a tek-screw (as shown in figure 10).

Now the unit will be easy to level and secure. Leveling the unit is very important to insure proper drainage of condensation (see below).

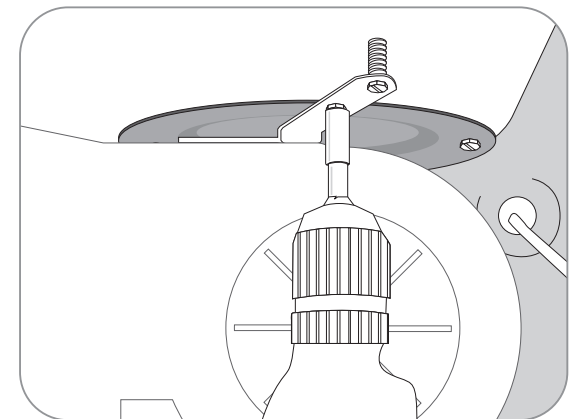

FIGURE 10

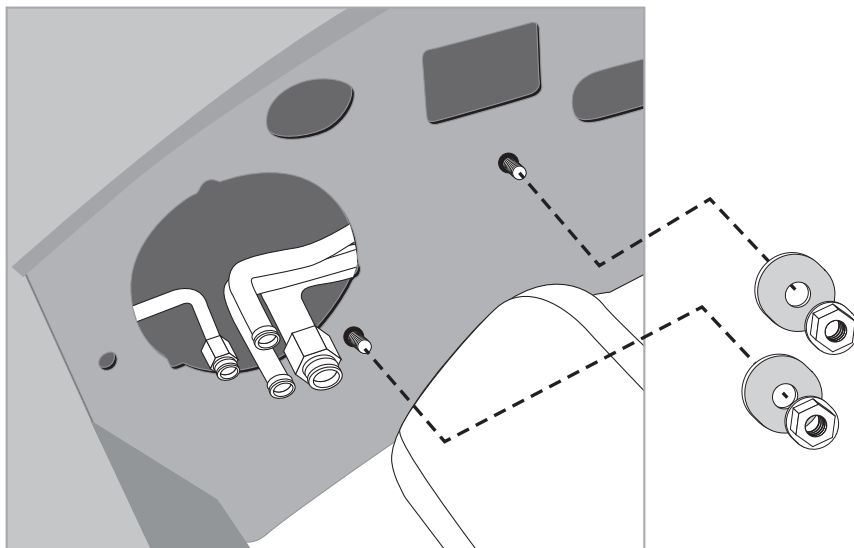
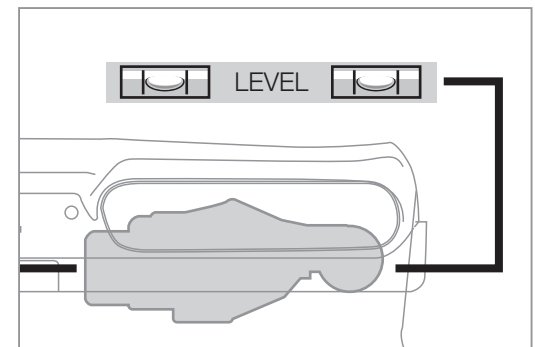

FIGURE 9



Be sure to align the evaporator unit level with the bottom of instrument panel (assuming the vehicle is sitting level) as shown above, but with a small degree of tilt toward the back to allow proper drain of condensation.



We've included a new underdash evaporator brace to replace the OEM one. Our new brace has a different bend and is an important replacement. Mount the brace to the new evaporator as shown below, and use an included flange nut to secure (there is a OEM stud that you will use to secure the top of the bracket, see figure 11).

IMPORTANT NOTE: On the side of the main unit you will see several holes for mounting holes... **ONLY USE THE ONES ON THE FAR LEFT FOR THIS BRACKET!** Do not tap into the other holes for any reason. Also, use a screwdriver and hand-power and do not over-tighten so you don't strip the holes (see figure 12).

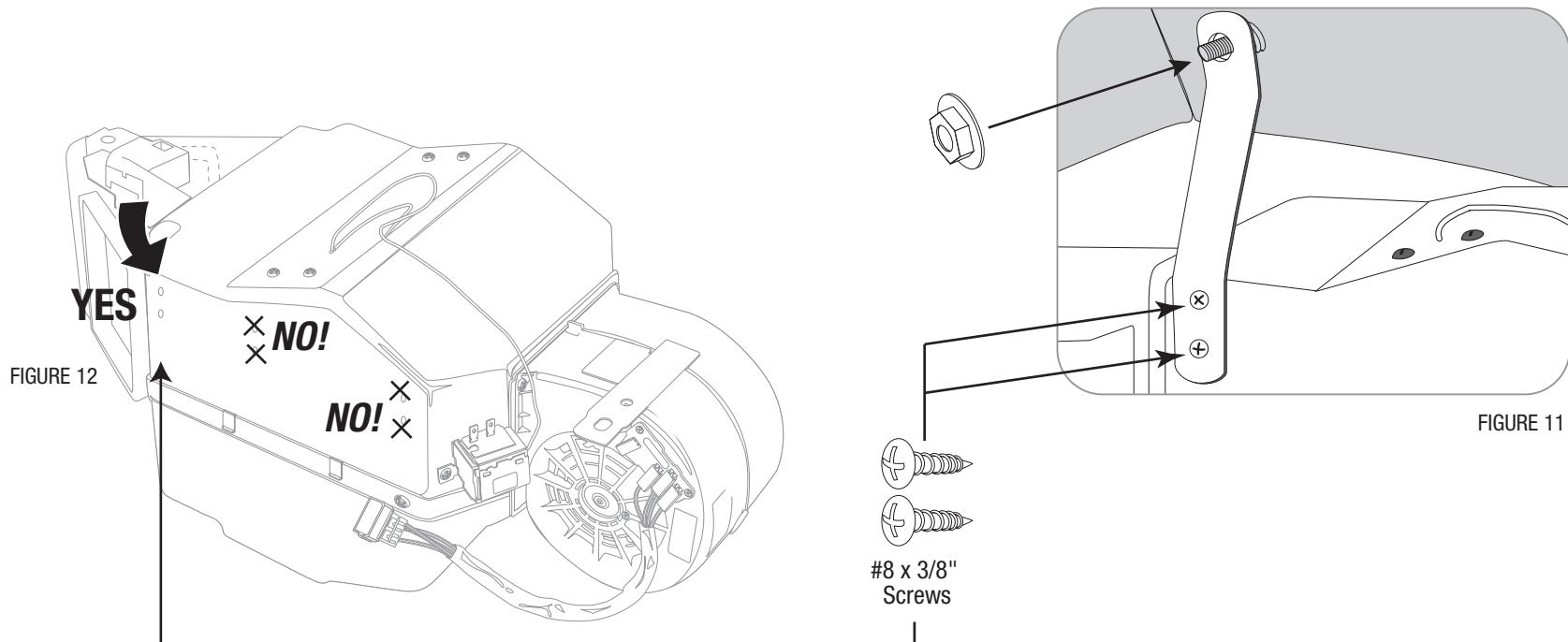

THESE ARE THE PARTS YOU WILL FIND IN BAG KIT C

You will use all of these parts and hardware during the next series of installation steps.

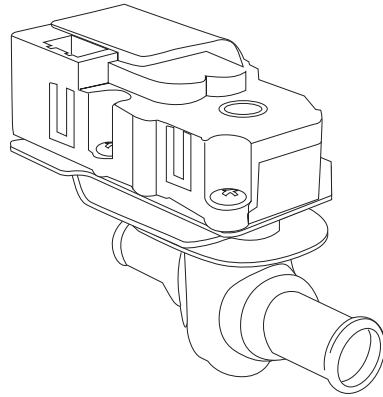

*Electronic Water Control Valve
PN# 16-1081-2*

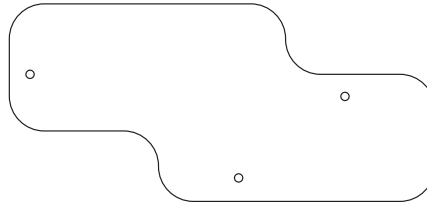

*Firewall Block Off Plate
PN #10-2066FA-2*

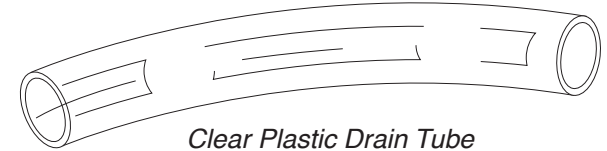

Clear Plastic Drain Tube

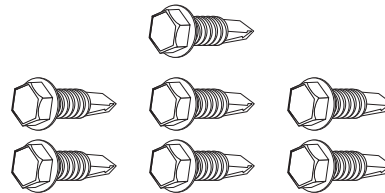

Seven #10 - 16 x 3/4" Tek Screws

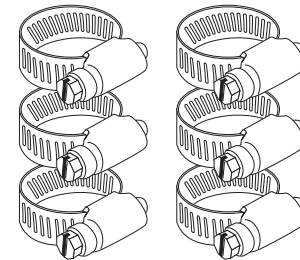

Six Worm Gear Clamps

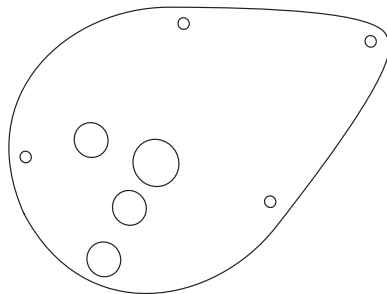

*Firewall Block Off
PN# 10-2066FA-1*



Four Cap Plugs

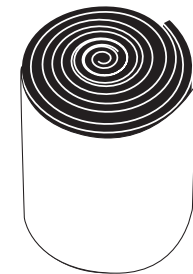

Refrigerant Tape

Illustrations NOT shown actual size

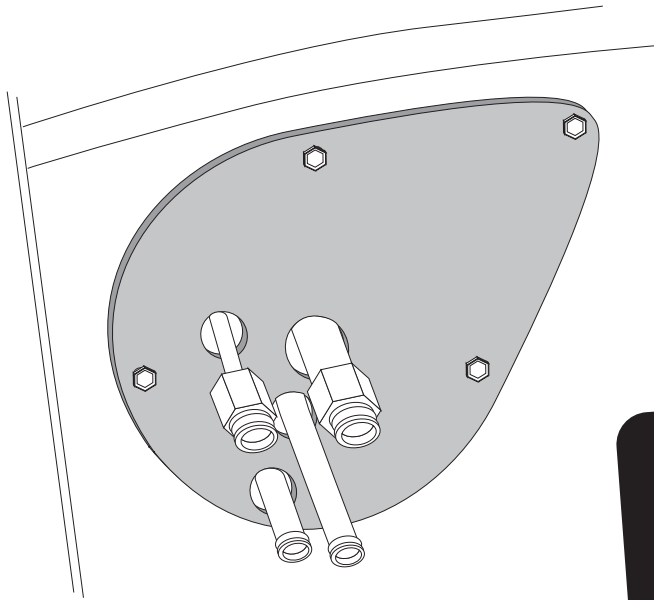

FIGURE 13

In **Bag Kit C** you'll find the firewall block off. Install this over the hose connections coming thru the firewall within the engine compartment. Attach with four Tek screws (see figure 13). **TIP: This would be a good time to "jump" ahead a bit, and remove the ORANGE cable from Bag Kit D and route it thru one of the OEM bolt holes (it will be plugged into the electronic water valve). Use the included cap plugs and seal off the remaining OEM holes.**

IMPORTANT NOTICE: PROPER INSTALLATION OF WATER VALVE INSTRUCTIONS!!!

Classic Auto Air has done extensive testing on the correct method to install the water valve in order to get a repeatable and progressive temperature control. **Your water valve MUST be installed per these instructions!... (if not, your system will not work properly... and that's an absolute fact).**

The **lower** connection on the tubes coming thru the block off assembly is going to be routed to the water outlet on the intake manifold. Attach your hose with cable clamps on both ends and route where it will not interfere with linkage or come in contact with exhaust manifolds or headers.

The **upper** port coming thru the firewall will be routed to and thru your new your electronic water valve (the water valve is marked for easy installation, see figure 14). First Attach a 6" piece of 5/8" dia. heater hose with the supplied worm gear clamp. Attach to the inlet side of the water valve using another supplied hose clamp. Attach a heater hose from the outlet side of the electronic water valve and route to the connection on the water pump.

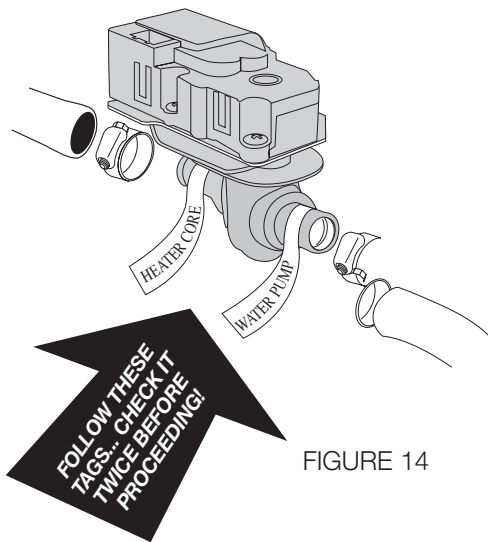

FIGURE 14

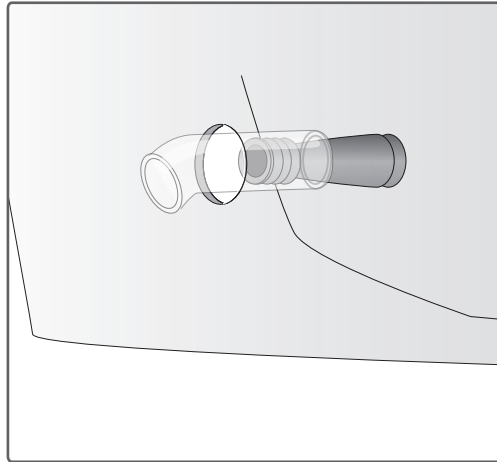

FIGURE 15

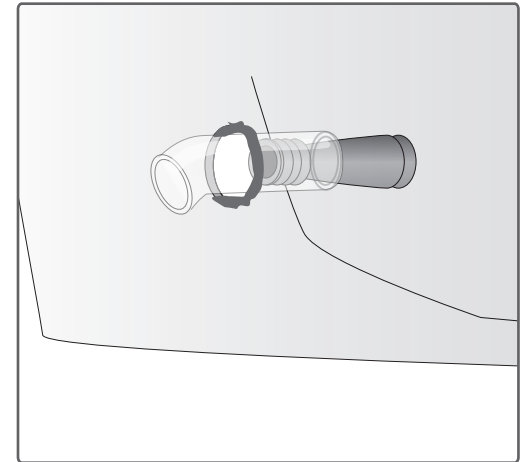

FIGURE 16

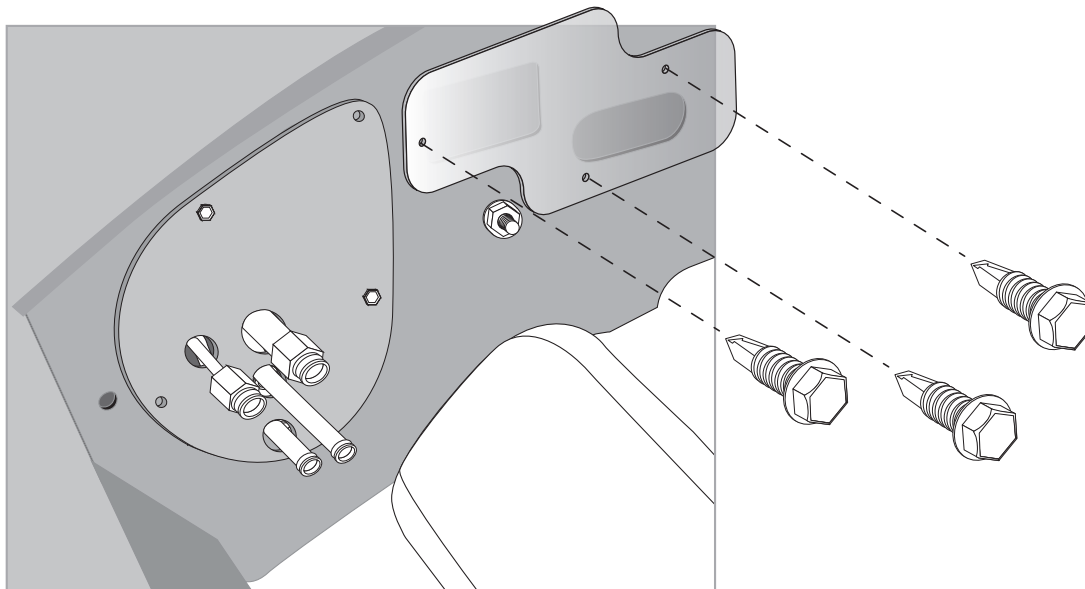

FIGURE 17

Insert a 6" piece of the clear drain tube we included through the hole previously drilled and attach over the drain nipple (see figure 15). Seal around tube hole with refrigerant tape (see figure 16).

We've also included an additional block off plate to cover the OEM hole for the water valve and heater tubes. Use the remaining tek-screws to secure the new plate (see figure 17).

THESE ARE THE PARTS YOU WILL FIND IN BAG KIT D

You will use all of these parts and hardware during the next series of installation steps.

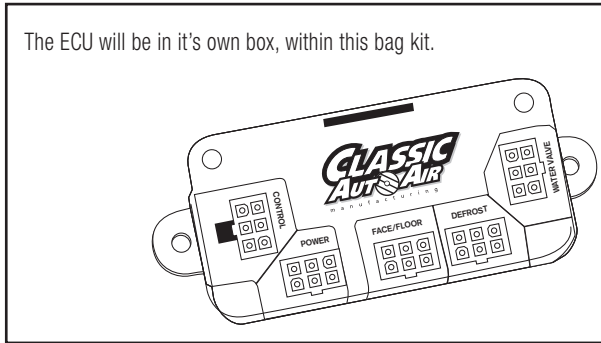

Two #10 - 16 x 3/4" Tek Screws

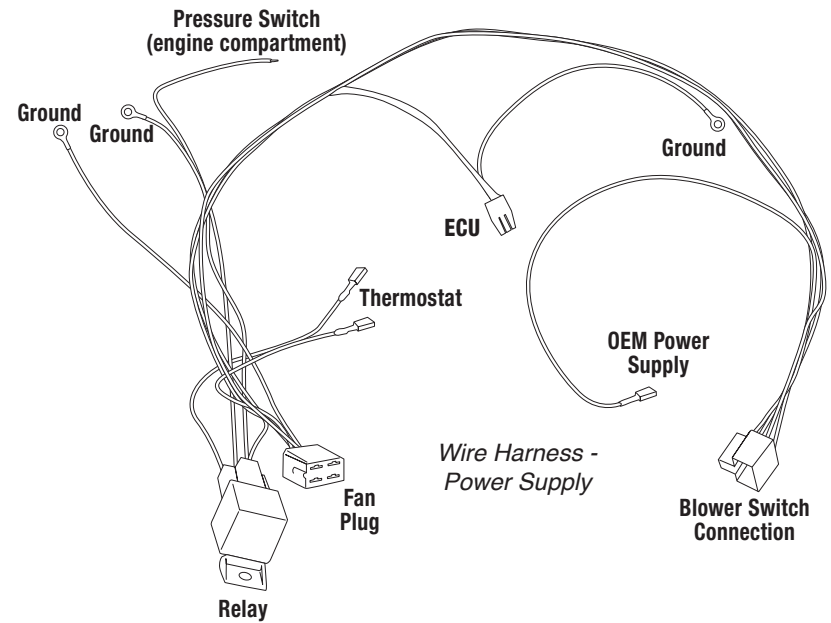
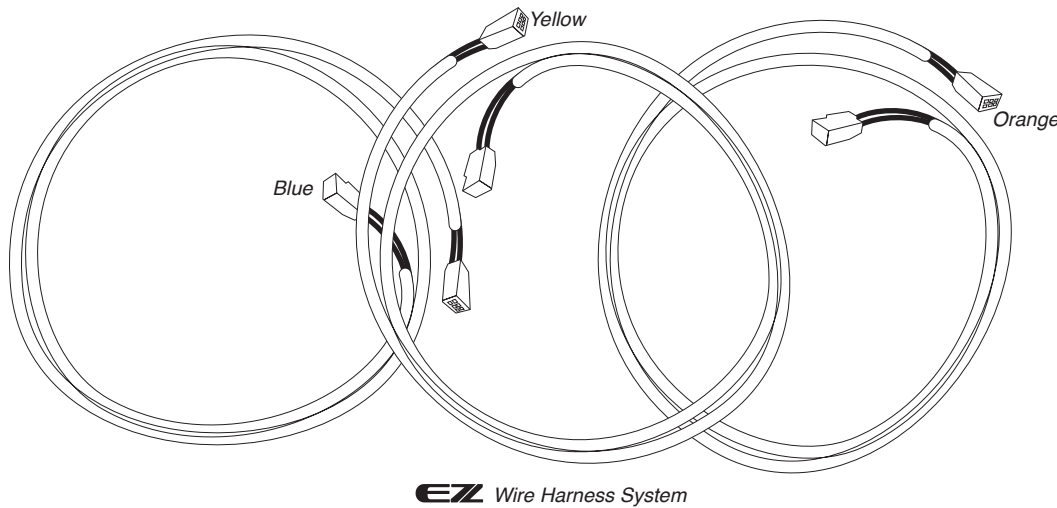

Illustrations NOT shown actual size

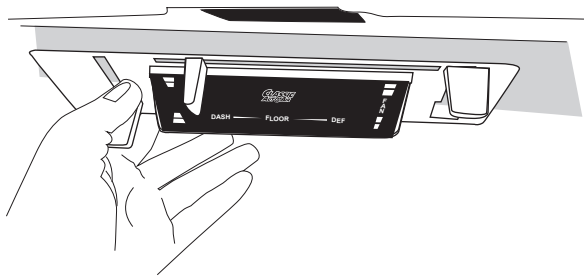

We've included enough extra cable length to allow you to mount the ECU in a variety of places. It is very important that you mount this in a place where it will stay dry and that vibration is at a minimum. Also make sure that where ever you mount it it does not interfere with any moving controls or cables. We recommend mounting it just above the right hand side of the main unit using the included tek-screws. **IMPORTANT! DON'T MOUNT THE ECU PERMANENTLY JUST YET. THAT CAN BE DONE AFTER YOU CALIBRATE THE UNIT .**

In Bag Kit D you will find three wiring harnesses with connections at each end. Plug the harness with YELLOW band into the YELLOW ECU port and the other end into the servo motor on the main unit (motor is marked with YELLOW INDICATOR). Repeat this process for the other two harnesses, following the color coding indicated on cables and ports. Attach cable in the engine compartment to the electronic water valve and route to one of the unused holes from the OEM unit.

CONTROL HEAD: The GREEN harness connection will be made to the blower switch on the control head. Attach the connection to the blower switch, then insert the control head back into the dash and secure with the OEM screws. Make the final connection to the ECU at the GREEN port.

Seal around the tubes with the included refrigerant tape. This will keep unwanted moisture and debris from entering thru the firewall... so seal carefully and thoroughly.

Wiring Diagram/Overview

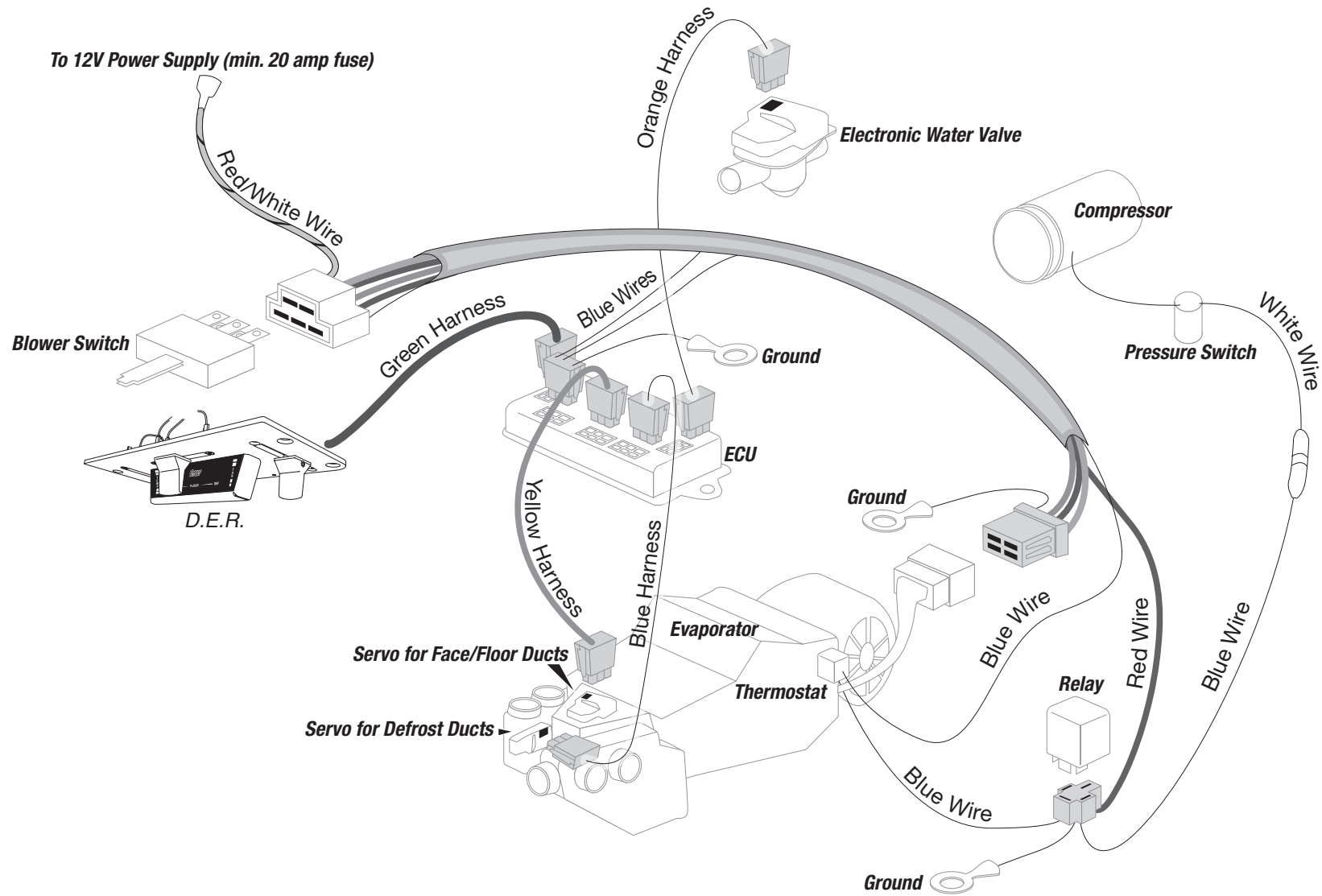

REMINDER: BE SURE THAT THE WIRING HARNESS DOES NOT INTERFERE WITH THE OPERATION OF ANY CONTROLS.

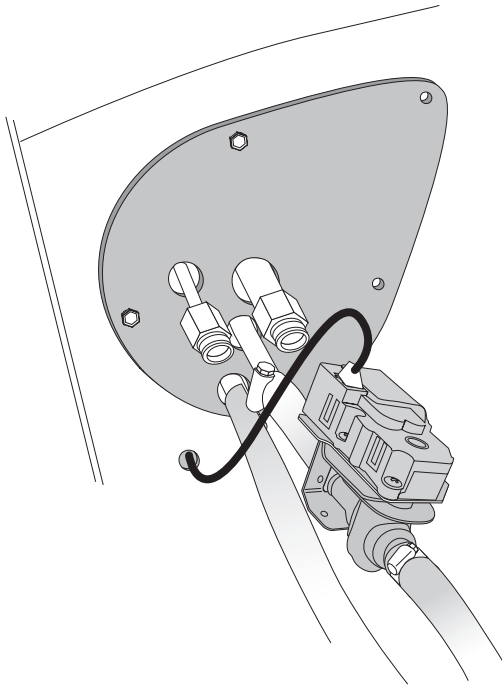

We've included enough extra cable length to allow you to mount the ECU in a variety of places. It is very important that you mount this in a place where it will stay dry and that vibration is at a minimum. Also make sure that where ever you mount it does not interfere with any moving controls or cables. We recommend mounting it just above the right hand side of the main unit using the included tek-screws. **IMPORTANT! DON'T MOUNT THE ECU PERMANENTLY JUST YET. THAT CAN BE DONE AFTER YOU CALIBRATE THE UNIT (SEE NEXT PAGE).**

In Bag Kit D you will find three wiring harnesses with connections at each end. Plug the harness with YELLOW band into the YELLOW ECU port and the other end into the servo motor on the main unit (motor is marked with YELLOW INDICATOR). Repeat this process for the other two harnesses, following the color coding indicated on cables and ports. Attach cable in the engine compartment to the electronic water valve and route to one of the unused holes from the OEM unit. Using one of the CAP PLUGS provided, slot it and install over hole. **NOTE:** The GREEN harness connection will be made from the harness you previously installed, just plug the loose connection in the CONTROL port on the ECU. We've also included two other cap plugs you can use to seal unused holes.

Seal around the tubes with the included refrigerant tape. This will keep unwanted moisture and debris from entering thru the firewall... so seal carefully and thoroughly.

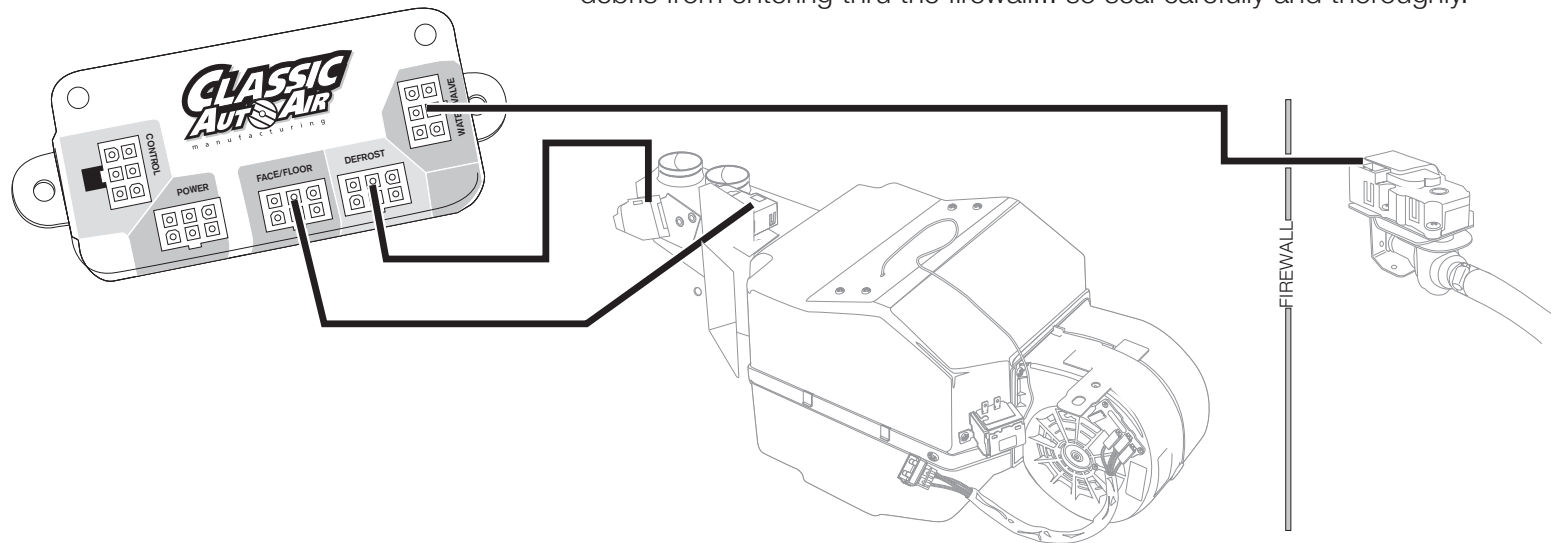



Temporarily reconnect the car battery at this time. You will need a full 12 volts to complete the calibration.

WELCOME TO EZ CALIBRATION...

Follow these directions carefully and your unit will be calibrated in just a few minutes.

Before we boxed and shipped your unit, we tested and calibrated it to factory specifications to make sure it is capable of operating at maximum efficiency. However, the unit must still be calibrated to your specific vehicle and controls. This is an easy process that can be done in a few steps. If for any reason your unit does not calibrate properly the first time, just turn off the unit and rerun the setup process. **NOTE: When you move a knob to a new position, do it in ONE continuous motion.**

| | | | |
|---|--|---|--|
| <p>#1</p> <p>Plug CALIBRATION KEY into ECU</p> | <p>#2</p> <p>Position your controls like this example.</p> | <p>#3</p> <p>Move FAN control to medium in one motion...</p> <p>LED ON 1 Second Later... LED OFF</p> | <p>#4</p> <p>Move MODE control to DASH in one motion...</p> <p>LED ON 1 Second Later... LED OFF</p> |
| <p>#5</p> <p>Move TEMP control to HOT in one motion...</p> <p>LED ON 1 Second Later... LED OFF</p> | <p>#6</p> <p>After 1 second the LED turns back ON</p> <p>You may be able to hear the internal door(s) move back and forth...</p> <p>Approx. 30 Seconds Later... LED OFF</p> | <p>#7</p> <p>Move the FAN knob to OFF (powers off unit)</p> | <p>#8</p> <p>REMOVE KEY AND STORE IN SAFE PLACE</p> |

That's it. Your unit is now fully calibrated. Disconnect the battery and move on to the next phase....

THESE ARE THE PARTS YOU WILL FIND IN BAG KITS E, F, and G

You will use all of these parts and hardware during the next series of installation steps.

Bag E

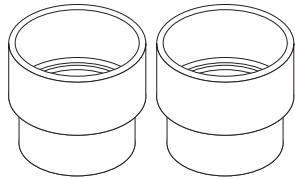

Two Defrost Duct Adaptors
PN #069-10

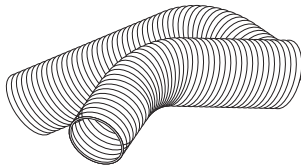

Two Duct Hoses, 2" I.D.

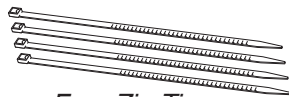

Four Zip-Ties

Bag F

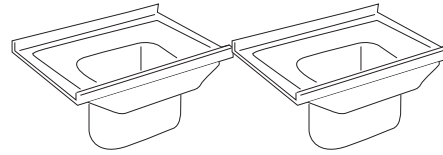

Two Duct Adaptors
PN# 2-2066FA-2

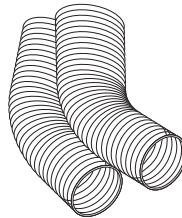

Two Duct Hoses, 2" I.D.

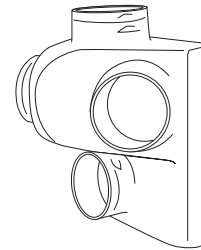

Face Duct Assembly
PN# 2-2025-1

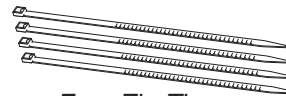

Four Zip-Ties

Bag G

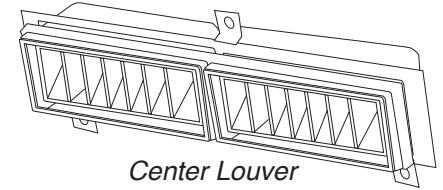

Center Louver
PN# 2-2066FA-3

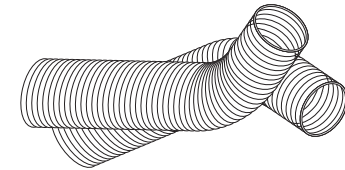

Two Duct Hoses, 2" I.D.

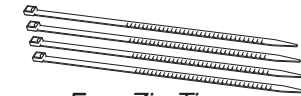

Four Zip-Ties

Illustrations NOT shown actual size

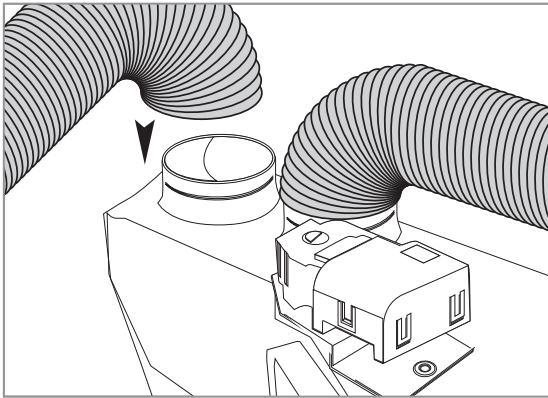
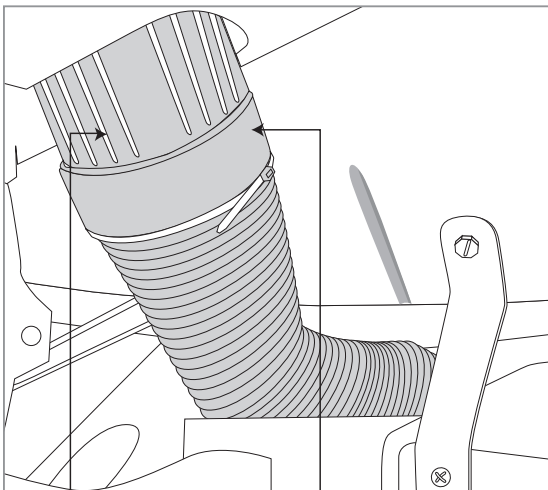

FIGURE 18

Bag Kit E: The following steps are for left and right Defrost Diffusers: Locate and route the duct hoses from the defrost/heat duct assembly (see figure 18) upward toward the defrost adaptor diffusers. Next locate and install defrost adaptor diffusers from the top of the dash and secure with v-clips supplied. Attach flex hose to the defrost diffuser adaptors using zip-ties. Push adaptors onto diffusers from below. The other end of the duct hose is installed over the defrost/heat duct assembly outlets on main unit.

The face duct assembly comes preinstalled with s-clips which allow you to install onto the evaporator unit quickly and securely (see figure 19).



Defrost Adaptor Diffuser

Defrost Adaptor Reducer

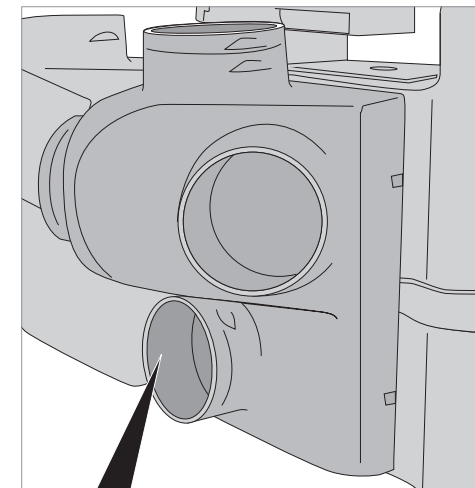
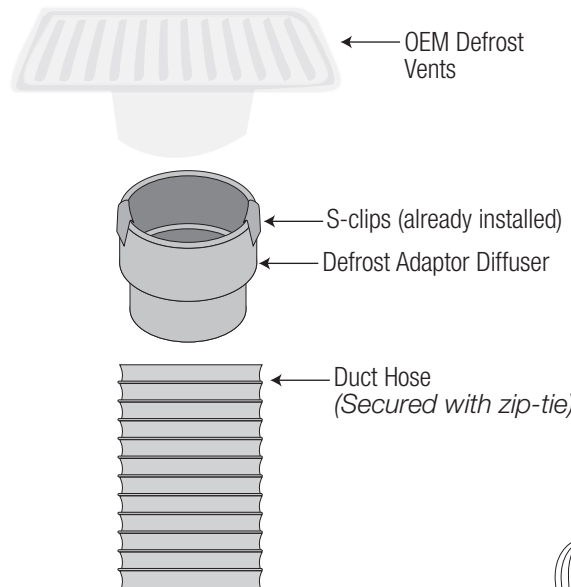
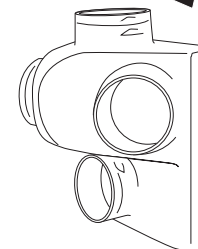

FIGURE 19





During installation of the hoses be aware of the eventual movement of the wiper arm components. Also, the smoother the route of the flex hoses the better the airflow.

Bag Kit F: We've included two left and right (driver and passenger) side vent adaptors. These come pre-installed with clip that will allow you to simple press them onto the back of the OEM vents. Next you can attach duct hose to each and route to the diffuser (as shown in figure 19).

TECH TIPS

FIGURE 19



Bag Kit G: In order to adapt to your OEM center louver you will need to utilize our center louver and adaptor. Remove the lower dash trim panel that contains the OEM center louver (see figure 20). Remove the OEM louver (retain the screws), insert your new center louver in it's place and secure with the OEM screws (see figure 21).

Go ahead and attach the duct hoses to the louver and route downward toward the evaporator, secure the duct hose at the louver with the included

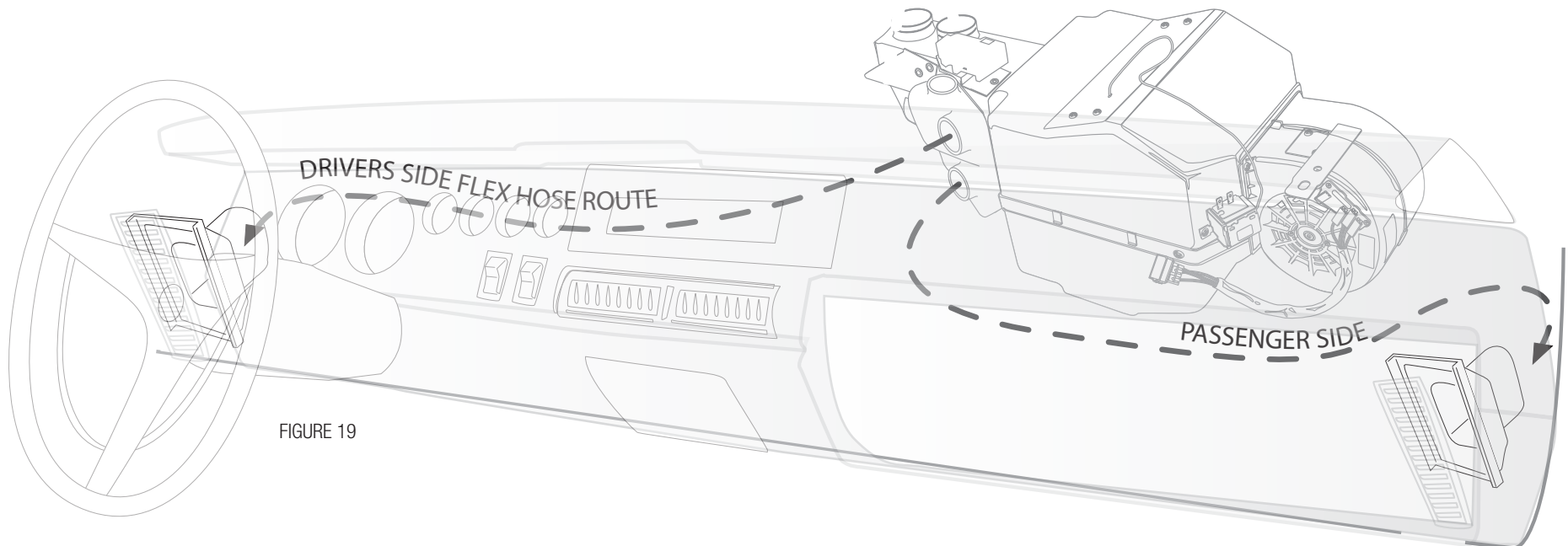
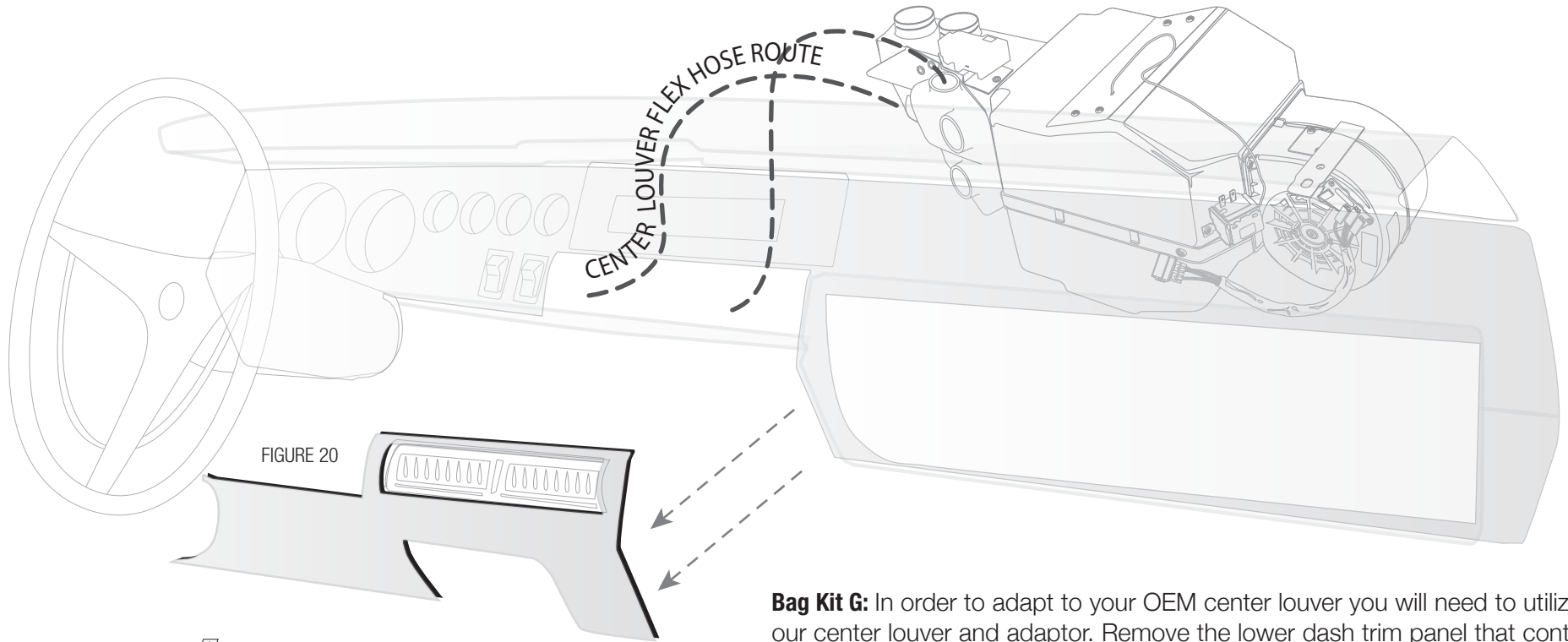
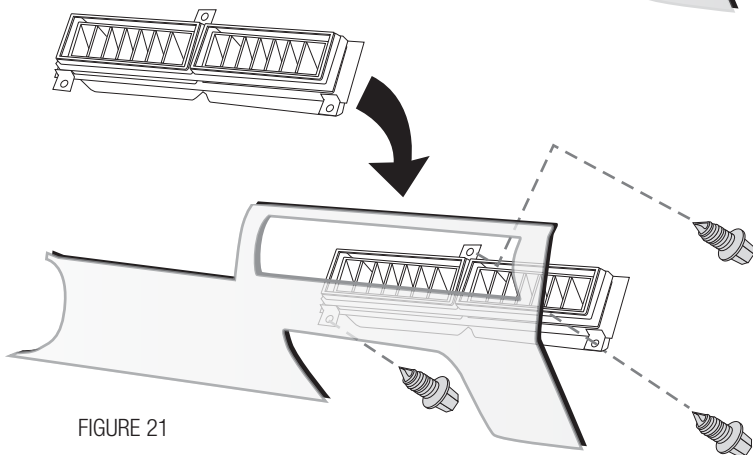
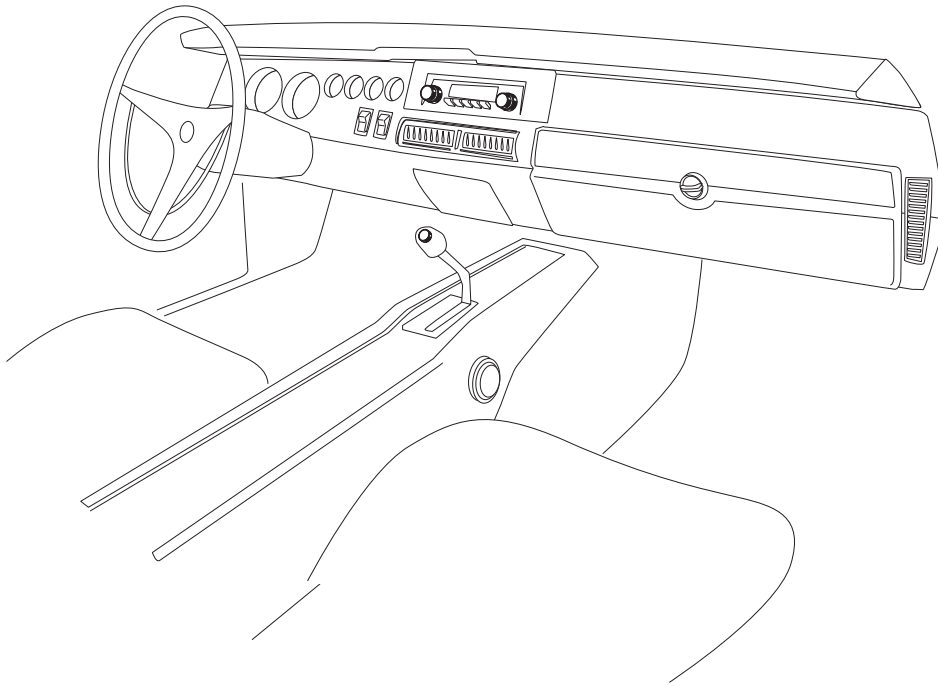

FIGURE 21



Reinstall any of the interior you may have removed. This is a good time to make a final check that all the controls still move freely and that nothing is loose or hanging down. This completes the interior portion of the **PERFECT FIT-ELITE** installation process.

The interior of your car should look pretty much the same as before you started (or better). Plus you probably got to know the underside of your dash a lot better and might even have repaired or upgraded components that needed attention.

Good Job... Let's move on to the major components within the engine compartment....



Retaining all the non-reinstalled OEM parts is a good idea, but that's your choice.



THESE ARE THE PARTS YOU WILL NEED FOR THE ENGINE COMPARTMENT INSTALLATION

You'll find all of these parts within the main box

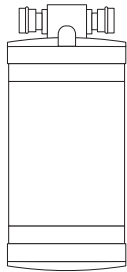

Drier
PN# 12-1008

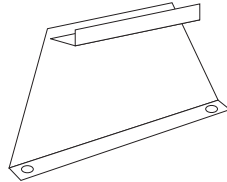

Condenser Bracket
PN# 0066-52

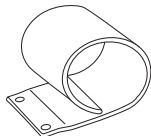

Drier Bracket
PN# 19-1001

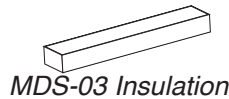

MDS-03 Insulation

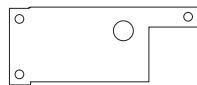

Condenser Bracket
PN# 0066-51

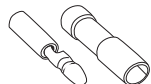

Splice and
Bullet Connector

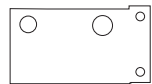

Condenser Bracket
PN# 0066-50

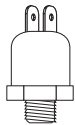

Pressure Switch

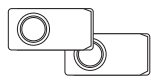

Two J-Clips



Bag of O-rings and
Mineral Oil Tube

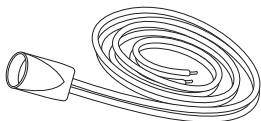

Pressure Switch Harness

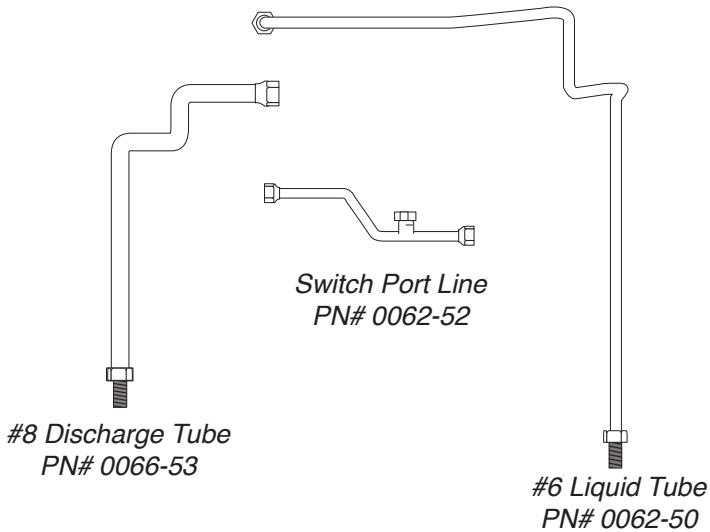

#8 Discharge Tube
PN# 0066-53

Switch Port Line
PN# 0062-52

#6 Liquid Tube
PN# 0062-50



#6 Hose
Clamp



#8 Hose
Clamp

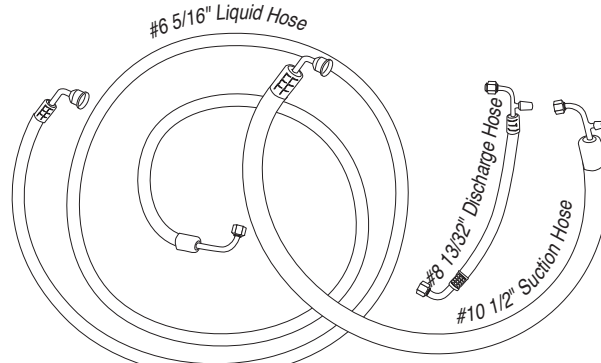

Three Refrigerant Hoses

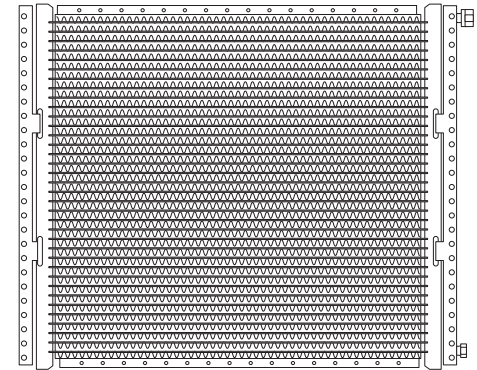

Condenser
PN# 11-1042



Four #10 X 1/4 Hex Head Screws



Four #10 - 16 x 3/4" Tek Screws



Four #1/4" 20 X 5/8" Bolts



Two #1/4" x 20 Flange Nuts

ENGINE COMPARTMENT INSTRUCTIONS

STEP ONE: IF YOU HAVE NOT ALREADY, DISCONNECT THE BATTERY.

STEP TWO: During the next installation section you'll be installing the condenser, drier, and routing the high/low pressure lines and the liquid line. Since much of this is installed in the OEM location for the condenser, you'll need to remove the center grill section, horn(s), and latch support assembly. Be sure to retain all the mounting screws – you'll reinstall these pieces in the exact reverse order with the OEM screws.

STEP THREE: Time to install the compressor kit. Included in your box is a premium compressor kit with all the parts you'll need to install the compressor. This kit includes easy to follow instructions specifically written for your engine. Once you've installed the complete compressor kit, continue on to the next step. We believe that this is the finest compressor kit available, and you're bound to notice the excellent fit and quality once this step is completed.

STEP FOUR: Install the Switch Port Line at the coming thru the firewall. Install the high pressure switch into the port on the Switch port line. **NOTE:** *Tighten connections at either end using supplied o-rings on both ends and a few drops of mineral oil to each o-ring. Screw the high-pressure switch into the port at the lower end of the drier liquid tube. Go ahead and plug the pressure switch harness into the switch at this time (black electrical boot with two long white wires. see figure 22).*

This will give you the correct location for installing the drier. Place the included drier bracket over the drier, and mount to the drier to the inner fender using the included tek-screws.

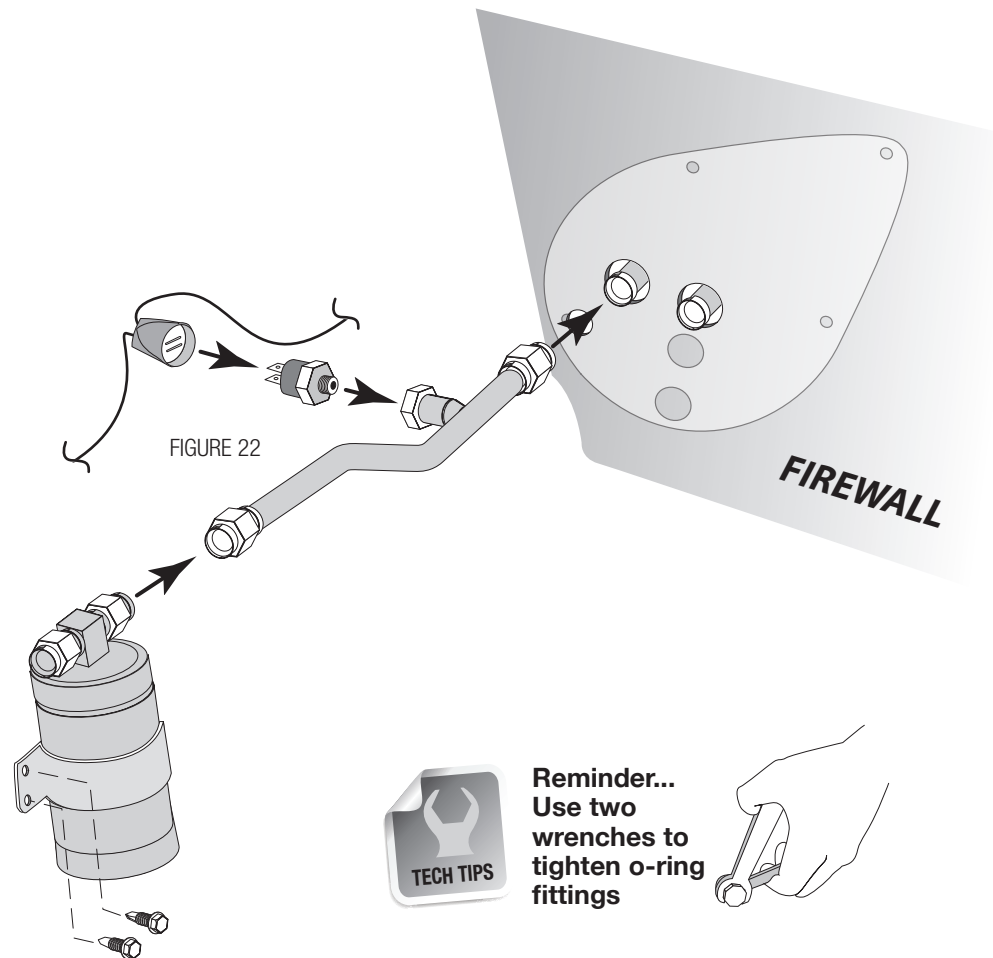

STEP FIVE: You can perform most of the following steps on a clean flat surface like a workbench. Lay the condenser down so that both hose connections are on the left side (the larger connection will be on top). Install the upper condenser brackets (A) using the included #10 x 1/4 hex screws. Both brackets are installed at the very top of the condenser, and from the backside. These brackets have holes that exactly correspond to bolts that are in the OEM radiator support (see figure 23).

STEP SIX: We've included a new lower condenser bracket (B). Locate the lower mounting bracket to bottom rail in front of the radiator. Attach two 1/4"-20 j-clip to the frame rail over the existing holes, and secure with two 1/4" x 20 x 5/8" hex screws. We've included a piece of MDS03 insulation with a self-adhesive back. Peel the backing off and place into the upper channel of the lower bracket (this will reduce vibration, see figure 24).

STEP SEVEN: Place the condenser into place and secure with a 1/4"-20 x 5/8" hex head screw and a 1/4 x 20 flange nut thru the existing holes in the radiator support on both sides (both brackets are secured in the same way).

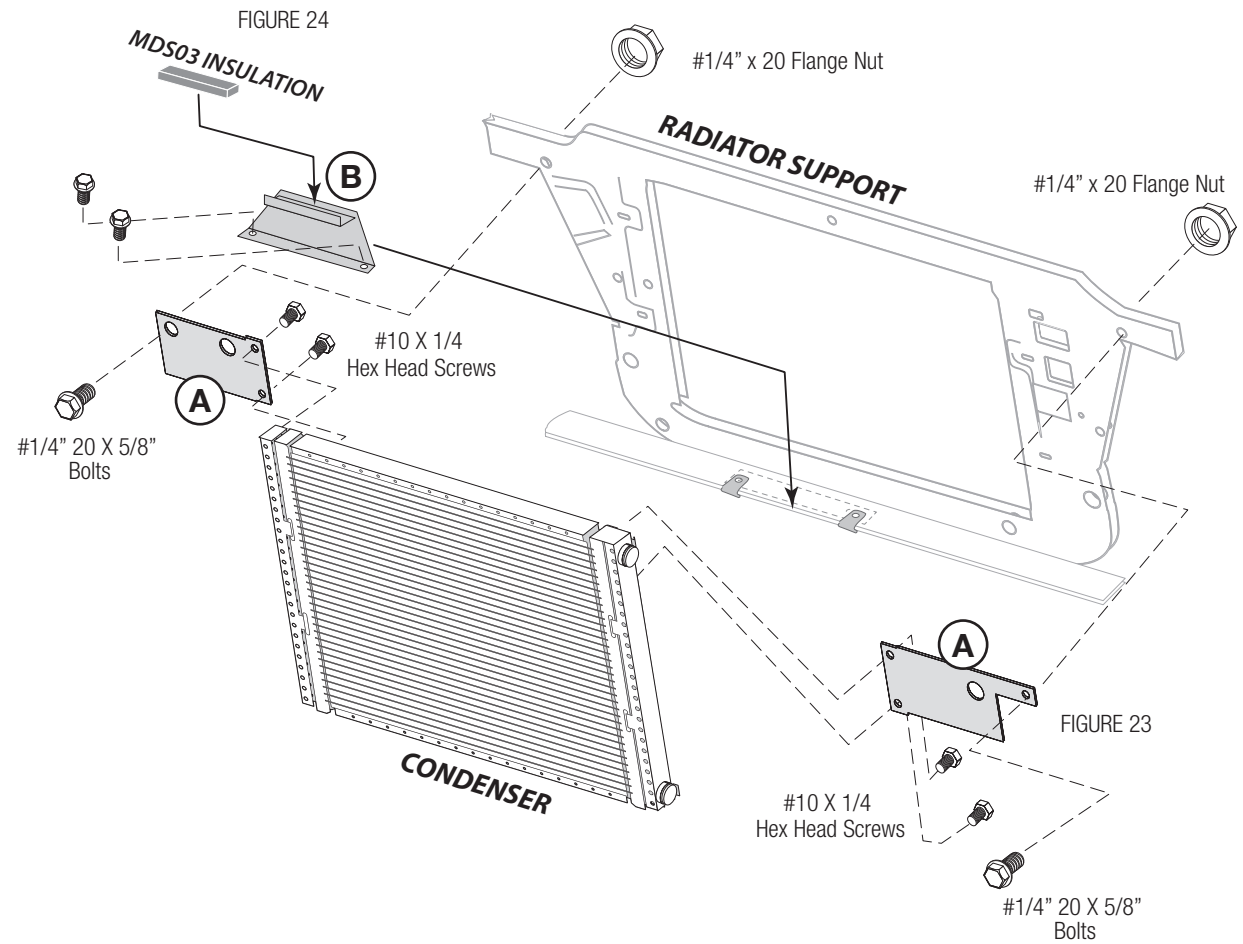

STEP EIGHT: You can now jog the discharge and liquids lines thru the existing upper rectangular hole in the radiator support, and then secure to the condenser. The longer line will be attached to the lower port on the condenser. The shorter line is attached to the upper port on the condenser. Test fit the routing before securing the fittings (see figure 25). **NOTE:** *Tighten connections at either end using supplied o-rings on both ends and a few drops of mineral oil to each o-ring.*

We've included two hose clamps which you can use to secure the lines to the drivers side inner fender area. Secure clamps with two #10 x 3/4" tek-screws (see figure 26).

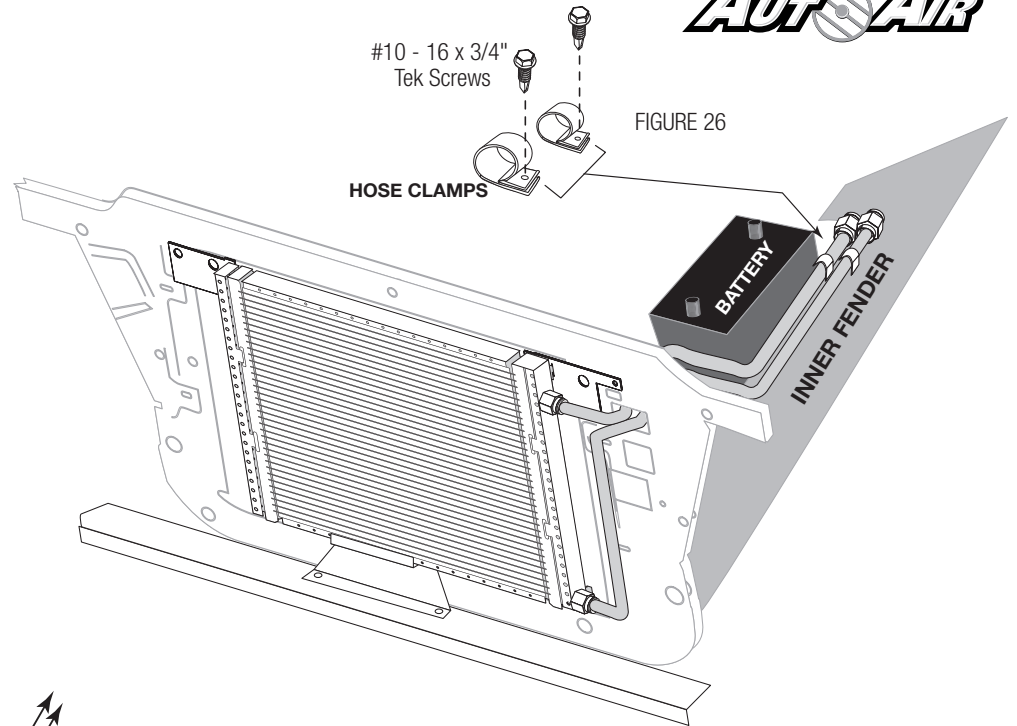
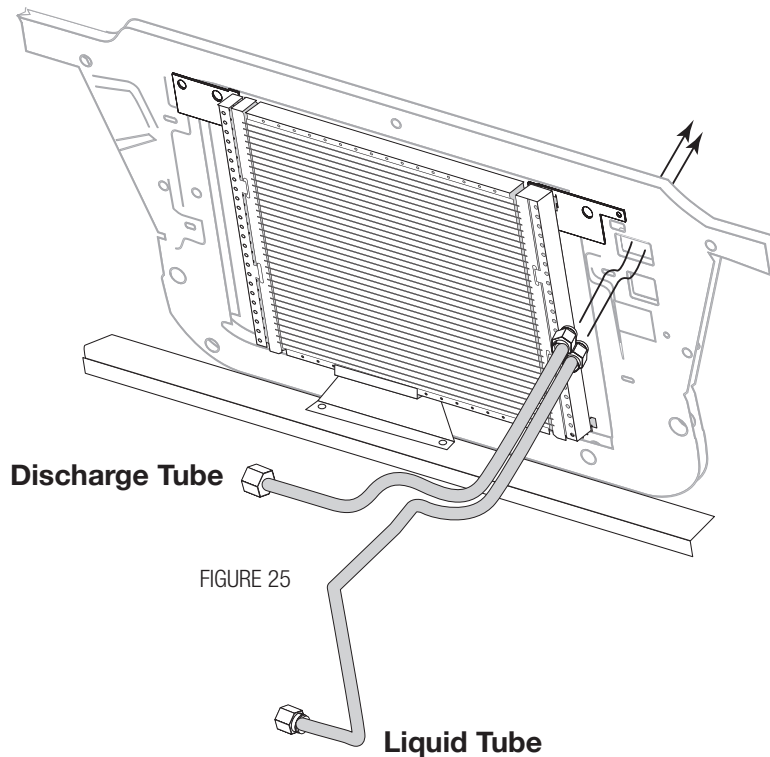

Reminder...
Use two
wrenches to
tighten o-ring
fittings



STEP NINE: CONNECTING THE HOSES (see figure 27):

1) Attach the #8 Discharge Hose (13/32") from the connection coming thru the support and route to the compressor. Tighten fittings using o-rings and mineral oil provided.

2) Attach the #6 liquid hose (5/16") from the connection coming thru the support and route to the connection evaporator unit (see figure 41). Tighten fittings using o-rings and mineral oil supplied in kit.

3) Attach the #10 suction hose (1/2") to the compressor and route to the last remaining connection coming thru the firewall. Tighten fittings using o-rings and mineral oil supplied in the kit.

TIPS: Route your lines so they will not interfere with moving parts or fall onto excessively hot components.

Double check all fittings before the initial servicing of your system. Loose fittings are the number one cause of leaks.

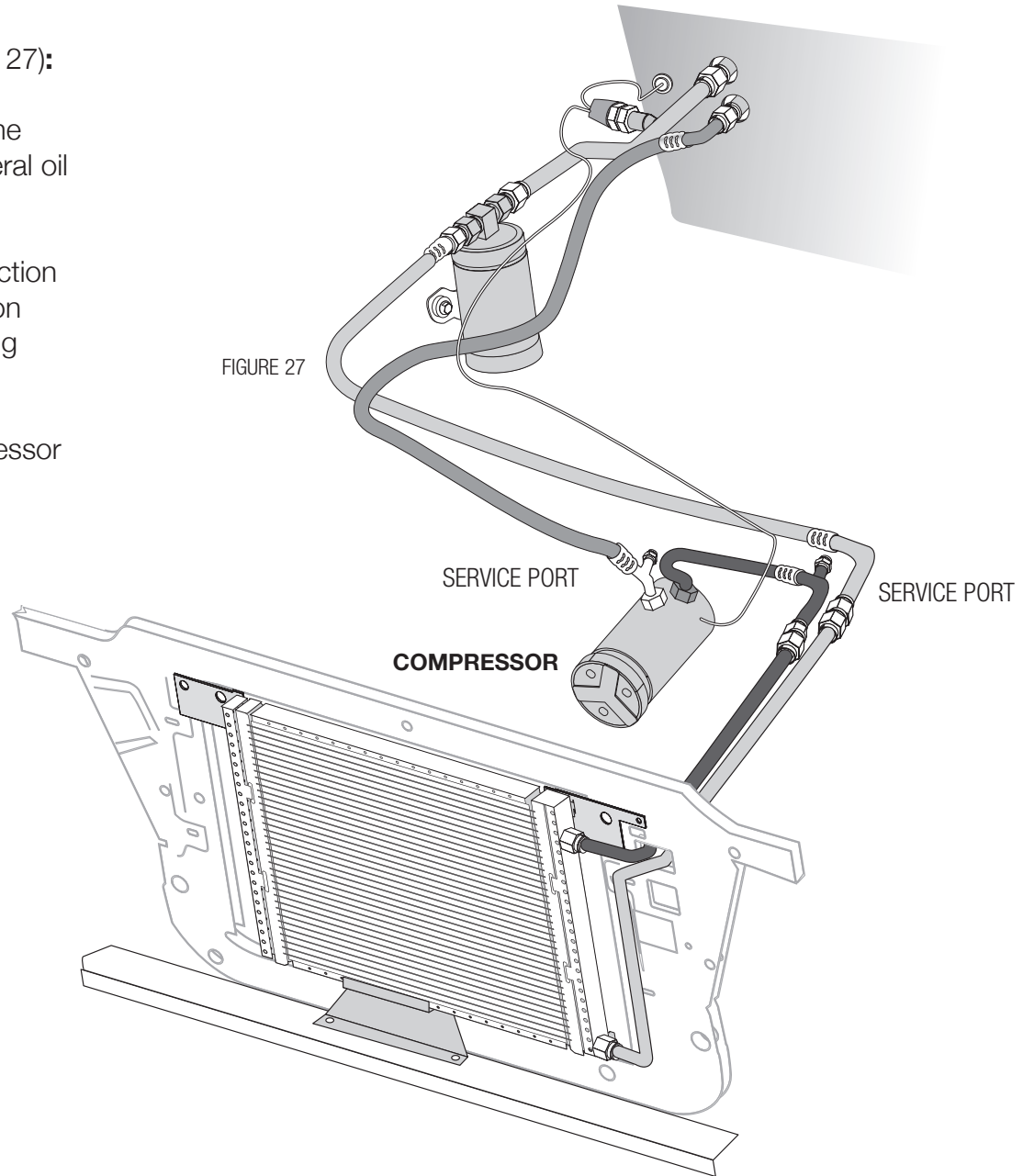



STEP TEN: Connecting the wires from the pressure switch will be done as follows, connect one wire to the connection on the compressor, and the other wire will be routed along with the liquid hose and connected to the blue lead you left unconnected during the interior installation. We've included a bullet and slice connector to make these connections, use a crimp tool to secure these properly. You must run the white switch wire thru the firewall and connect to the blue wire from the main harness.

FINAL STEPS: You can now complete this portion of the installation by reinstalling any of the exterior components you removed. Take a look around at your installation and check all fitting and bolts for tightness, check the heater hose clamps for tightness, and make sure nothing is routed in a way to obstruct any moving parts.

You can refill the radiator and reconnect the battery at this time.

WAY TO GO! You've just completed the installation of your new A/C system.

***The final step is to fully charge and test your new system.
On the next page you'll find specifications for
proper final preparation for your A/C technician.***



New A/C System Preparation... A MUST READ!

Please read thru these procedures before completing this new A/C system charging operation.

A licensed A/C technician should be utilized for these procedures to insure that your new system will perform at it's peak, and that your compressor will not be damaged.

- 1) Your radiator/cooling system is an integral part of your new system. Please insure that you have a 50/50 mix of distilled water and antifreeze. The heater coil **MUST** be purged (cycle heater control valve) to make sure no water, without antifreeze, is in the heater coil before you charge the A/C system.
- 2) Evacuate the system for 45 minutes (minimum).
- 3) **Your new compressor MUST be hand-turned 15-20 revolutions before and after charging with liquid. Failure to do this may cause the reed valves to become damaged** (this damage is NOT covered by your warranty).
- 4) Your new system requires 134a refrigerant. It will require 1.5 lbs (or 24 oz).
- 5) Your new compressor comes charged with oil - NO additional oil is needed.
- 6) Insure that the new belt is tight.
- 7) **DO NOT CHARGE SYSTEM WITH LIQUID WHILE THE ENGINE IS RUNNING!**

RECOMMENDED TEST CONDITIONS: (After system has been fully charged and tested for basic operation)

- Determine the temperature outside of the car
- Connect gauges or service equipment to high/low charging ports
- Place blower fan switch on medium
- Close all doors and windows on vehicle
- Place shop fan directly in front of condenser
- Run engine idle up to approx. 1500 rpm

ACCEPTABLE OPERATING PRESSURE RANGES:

1. HIGH-SIDE PRESSURES (150-250 PSI)
2. LOW-SIDE PRESSURES (15-25 PSI in a steady state)

Readings above are based on an ambient temperature of 90° with an adequate airflow on condenser

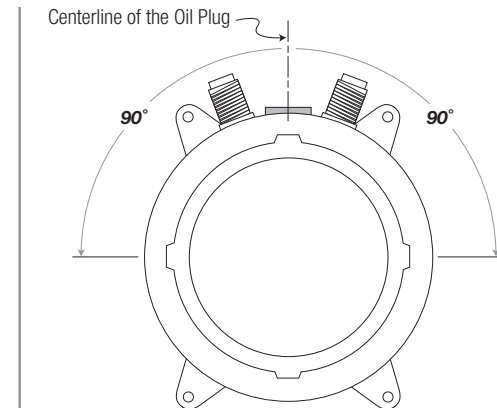

CAUTION! When mounting your compressor and/or adjusting the belt, use caution not to tilt the compressor up to or more than 90° off the centerline of the oil fill plug. This can cause compressor failure.

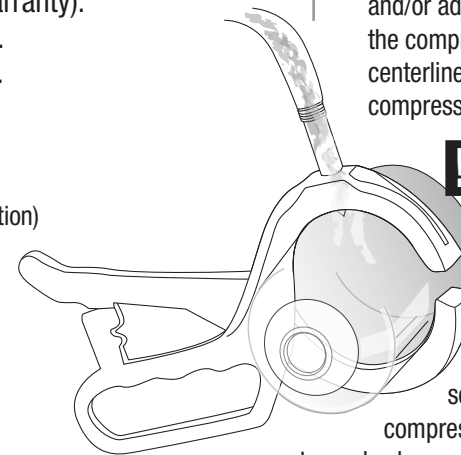

Do NOT tilt, shake or turn refrigerant can upside-down OR use a charging station to install refrigerant while the engine is running. Doing so will direct liquid refrigerant into the compressor piston chamber, causing damage to reed valves and/or pistons and/or other components, as well as potentially seizing the compressor. Allow a minimum of 30 minutes for liquid to "boil off." You must hand turn the compressor hub (not the pulley) a minimum of 15 complete revolutions prior to starting the engine with the clutch engaged.

TROUBLESHOOTING GUIDE

TEST CONDITIONS USED TO DETERMINE SYSTEM OPERATION

(THESE TEST CONDITIONS WILL SIMULATE THE AFFECT OF DRIVING THE VEHICLE AND GIVE THE TECHNICIAN THE THREE CRITICAL READINGS THAT THEY WILL NEED TO DIAGNOSE ANY POTENTIAL PROBLEMS).

- B. CONNECT GAUGES OR SERVICE EQUIPMENT TO HIGH/LOW CHARGING PORTS.
- C. PLACE BLOWER FAN SWITCH ON MEDIUM.
- D. CLOSE ALL DOORS AND WINDOWS ON VEHICLE.
- E. PLACE SHOP FAN IN FRONT OF CONDENSER.
- F. RUN ENGINE IDLE UP TO 1500 RPM.

ACCEPTABLE OPERATING PRESSURE RANGES (R134A TYPE)

1. HIGH-SIDE PRESSURES (150-250 PSI) **Note- general rule of thumb is two times the ambient (daytime) temperature, plus 15-20%.*
2. LOW-SIDE PRESSURES (15-25 PSI in a steady state).

CHARGE AS FOLLOWS: R134A = 24 OZ.

NO ADDITIONAL OIL IS NECESSARY IN OUR NEW COMPRESSORS.

TYPICAL PROBLEMS ENCOUNTERED IN CHARGING SYSTEMS

NOISY COMPRESSOR. A noisy compressor is generally caused by charging a compressor with liquid or overcharging

- A. If the system is overcharged both gauges will read abnormally high readings. This is causing a feedback pressure on the compressor causing it to rattle or shake from the increased cylinder head pressures. System must be evacuated and re-charged to exact weight specifications.
- B. **Heater control valve installation** - Installing the heater control valve in the incorrect hose. Usually when this occurs the system will cool at idle then start to warm up when raising the RPM's of the motor. **THE HEATER CONTROL IS A DIRECTIONAL VALVE; MAKE SURE THE WATER FLOW IS WITH THE DIRECTION OF THE ARROW.** As the engine heats up that water transfers the heat to the coil, thus overpowering the a/c coil. A leaking or faulty valve will

have a more pronounced affect on the unit's cooling ability. Installing the valve improperly (such as having the flow reversed) will also allow water to flow through, thus inhibiting cooling. Check for heat transfer by disconnecting hoses from the system completely. By running down the road with the hoses looped backed through the motor, you eliminate the possibility of heat transfer to the unit.

- C. **Evaporator freezing** - Freezing can occur both externally and internally on an evaporator core. External freeze up occurs when the coil cannot effectively displace the condensation on the outside fins and the water forms ice (the evaporator core resembles a block of solid ice), it restricts the flow of air that can pass through it, which gives the illusion of the air not functioning. The common cause of external freezing is the setting of the thermostat and the presence of high humidity in the passenger compartment. All door and window seals should be checked in the event of constant freeze-up. A thermostat is provided with all units to control the cycling of the compressor.
- D. **Internal freeze up** occurs when there is too much moisture inside the system. The symptoms of internal freeze up often surface after extended highway driving. The volume of air stays constant, but the temperature of the air gradually rises. When this freezing occurs the low side pressure will drop, eventually going into a vacuum. At this point, the system should be checked by a professional who will evacuate the system and the drier will have to be changed.
- E. **Inadequate airflow to condenser** - The condenser works best in front of the radiator with a large supply of fresh air. Abnormally high pressures will result from improper airflow. Check the airflow requirements by placing a large capacity fan in front of the condenser and running cool water over the surface. If the pressures drop significantly, this will indicate the need for better airflow.
- F. **Incorrect or inadequate condenser capacity** - Incorrect condenser capacity will cause abnormally high head pressures. A quick test that can be performed is to run cool water over the condenser while the system is operating, if the pressures decrease significantly, it is likely a airflow or capacity problem.
- G. **Expansion valve failure** - An expansion valve failure is generally caused by dirt or debris entering the system during assembly. If an expansion valve fails it will be indicated by abnormal gauge readings. A valve that is blocked will be indicated by high side that is unusually high, while the low side will be unusually low or may even go into a vacuum. A valve that is stuck open will be indicated by both the high and low pressures rising to unusually high readings, seeming to move toward equal readings on the gauges.
- H. **Restrictions in system** - A restriction in the cooling system will cause abnormal readings on the gauges. A high-side restriction (between the compressor and the drier inlet) will be indicated by the discharge gauges reading excessively high. These simple tests can be performed by a local shop and can help determine the extent of the systems problem.

Trouble Shooting Your Classic Auto Air A/C System

PROBLEM: system is not cooling properly
ISSUE: cold at idle, warmer when raising engine RPM's

Make sure the Water Valve is positioned correctly

The water valve is a directional valve and should be installed with the arrow pointing towards the water pump, it should be connected to the heater hose that runs from the heater core to the water pump. If the water valve is connected to the incorrect hose it allows water to circulate through the system via the heater core over powering the cooling effect of the A/C coil, (normally the air conditioning is functioning properly).

Step 1: Check placement of the water valve, correct if needed. (In some cases changing the location of the water valve may not fix the above problem.) Continue to next step.

Step 2 If changing the location of the water valve does not rectify the issue, then possibly the water valve is permanently damaged and may need to be replaced. To check the integrity of the water valve completely remove the water hoses for the heater core and "loop" together. (This will remove the heater system completely from the possibilities) If the system now cools, replace the water valve

Verify Adequate Air Flow to Condenser

For an air conditioning system to function properly there has to be adequate airflow across the condenser. The function of the condenser is to dissipate heat, without proper airflow your system will not cool correctly in the cabin of your vehicle.

Step 1: connect gauges to a/c hoses. The pressures should be: with the ambient temp is 90, low side pressures should be between 8-25 psi, high side pressures should be between 160-260psi

Step 2: IF the low side pressures are normal and the high side pressures are high then there might be an airflow issue, continue to next step.

To test air flow to Condenser do the following three tests:

1. Place a piece of paper on the condenser with the car in idle and see if paper is held in place.
2. With car in idle, attach gages, and place a large capacity fan in front of the condenser. What happens to the pressures?
3. With car still in idle and gages attached, pour water down the front of the condenser. What happens to the pressures?

If the paper is held in place you are at least getting some air flow. If the high side decreases during test 2 & 3 then your condenser is not getting enough air which is causing your system to not cool properly. To correct this issue you will need a more powerful mechanical fan.

Step 3: Confirm correct Refrigerant charge in System

All of our systems should be charged with 24oz or 1.8lbs of R134 Refrigerant only. If overcharged you will need to evacuate the system and recharge with the correct amount.*

What measurements mean:

Low Temp and High Pressure seem to be equal...

You have a malfunctioning expansion valve that is stuck open.

High Side is extremely high and Low Side is extremely low (possibly into vacuum)...

There is a blockage in the system. Remove hoses and blow compressed air through in both directions. If pressures don't change its possible that your expansion valve is stuck closed and would have to be replaced.

***Compressor Concerns:**

This is often misdiagnosed as a problem for the system not cooling properly. If you have a noisy compressor it is due to improper charging of refrigerant. An overcharged (more than 24oz or 1.8lbs R134) compressor can cause rattling. If charged with pure liquid there is a high probability you have bent reed valves that are causing tapping sound.



**IF YOU PRINTED THIS MANUAL
PLEASE READ THIS...**

Just as a cautionary step, please
measure this box and make sure it
is 1" x 1". Some copiers/printers
may not print at 100% of actual size.



**THIS TEMPLATE IS USED
FROM THE INSIDE OF THE CAR!**

**HEATER MOTOR
HOLE**

O.E.M. HOLE

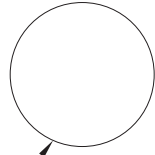

**5/8"
NEW DRAIN TUBE
HOLE**

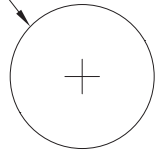

Note: bottom of template is parallel with floor pan



