

# INSTALLATION INSTRUCTIONS FOR UPPER CONTROL ARM BUSHINGS

**(RP15130)**

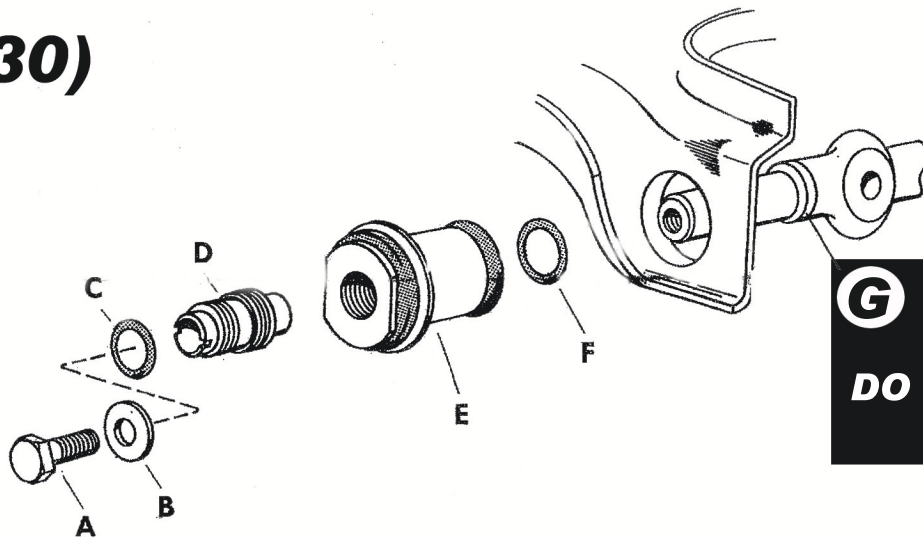

**G CAUTION**  
**DO NOT REMOVE**  
**WASHER**

1. Remove the retaining bolt "A", and washer "B". Do not discard.
2. Remove the O' Ring "C" and threaded center tube "D" and discard.
3. Remove the bushing "E", using an air chisel or similar tool to drive out the outer metal tube. Remove the O' Ring "F" and discard.

**NOTE:** Do not remove the small flat washer "G" from the control arm shaft. Removal of the washer "G" may cause failure of the unit unless you are using the Rare Parts design.

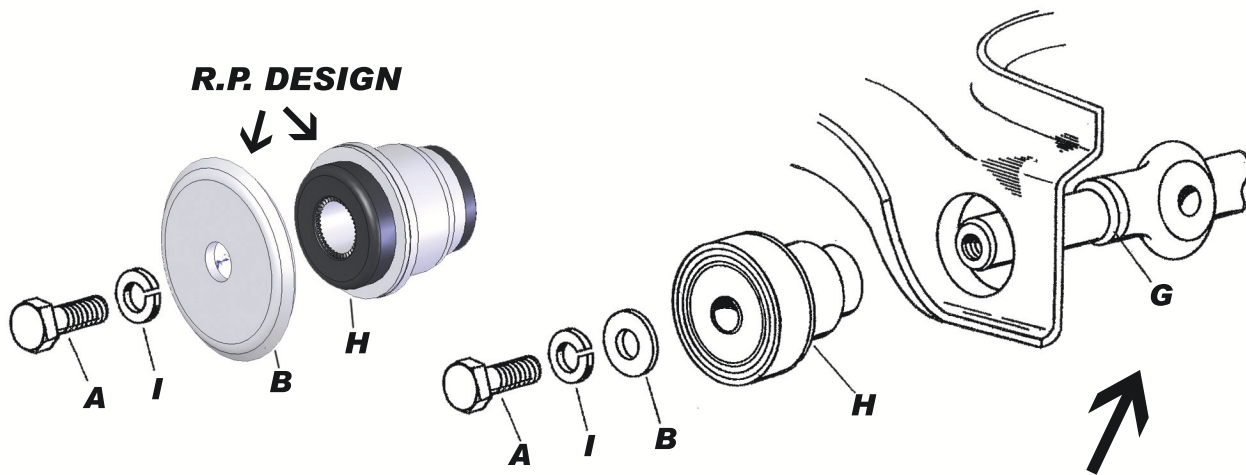

4. If you have the Rare Parts design, you must remove washer "G".
5. Install the replacement bushing "H" in the control arm. Caution: Do not press on the center area of the bushing, since this could result in damage to the flexible member. The bushing "H" may be installed by pressing on the outer flange with a suitable length of steel tubing until the bushing bottoms in the control arm.
6. Install the retaining bolt "A", lock washers "I" and washer "B". Tighten to 35 - 45 ft. lbs. of torque.
7. Front end alignment is recommended.