

GROSS LOAD CAPACITY WHEN USED AS A WEIGHT CARRYING HITCH: 2,000 LBS. TRAILER WEIGHT & 200 LBS. TONGUE WEIGHT.

\*\*\*DO NOT EXCEED VEHICLE MANUFACTURER'S RECOMMENDED TOWING CAPACITY.\*\*\*

WARNING: ALL NON-TRAILER LOADS APPLIED TO THIS PRODUCT MUST BE SUPPORTED BY 18050 STABILIZING STRAPS.

\*\* FAILURE TO PROPERLY SUPPORT NON-TRAILER LOADS WILL VOID PRODUCT WARRANTY\*\*

HAVING INSTALLATION QUESTIONS? CALL TECHNICAL SUPPORT AT 1-800-798-0813

Parts List			
ITEM	QTY	PART NUMBER	DESCRIPTION
1	2	M10 - 1.5 x 40mm	HEX BOLT
2	2	7/16"	CONICAL TOOTHED WASHER
3	4	M8-1.25 x 35	HEX BOLT
4	4	5/16"	WASHER
5	4	M8-1.25	HEX NUT
6	4	3/8"	CONICAL TOOTHED WASHER

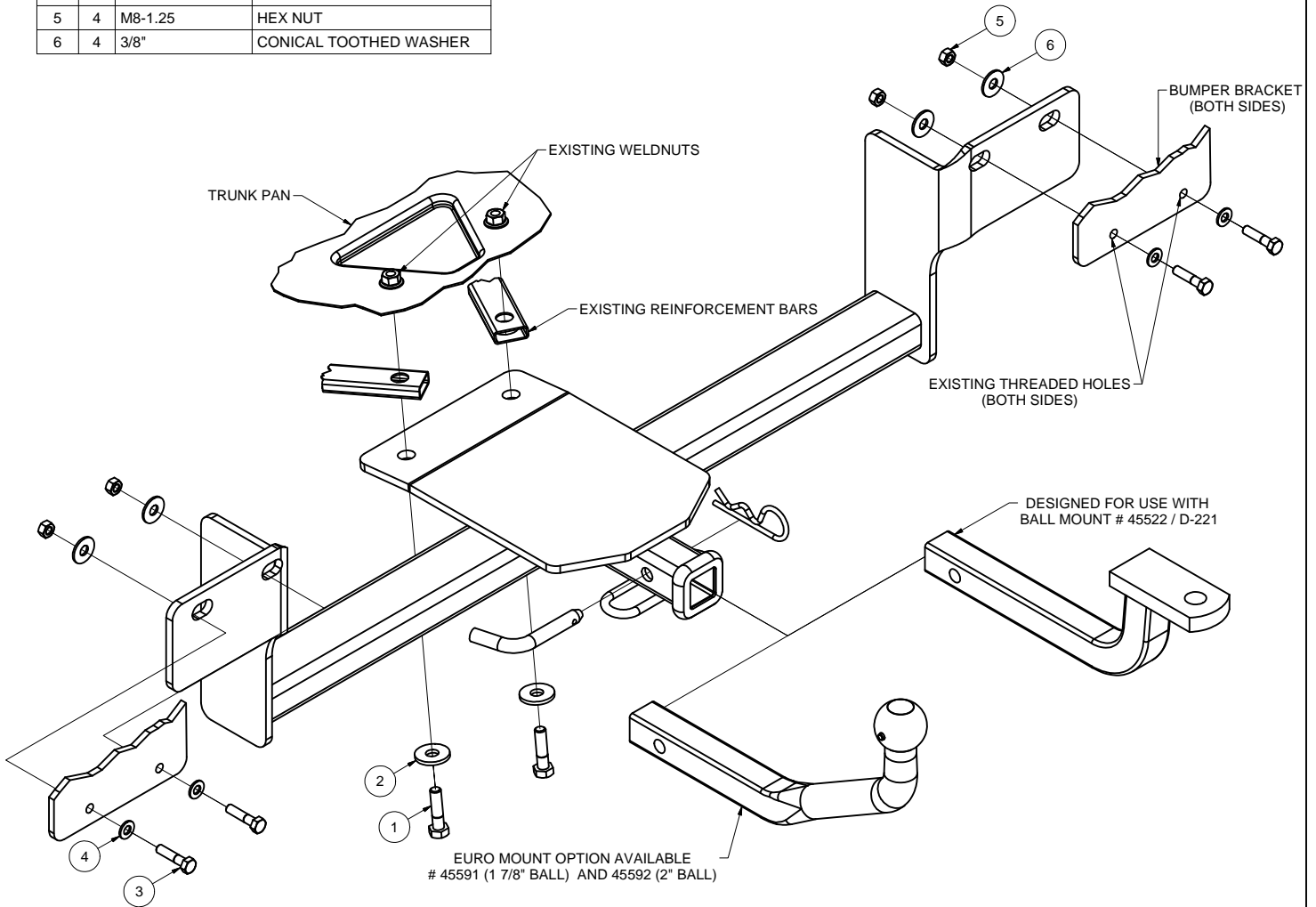

**HITCH WEIGHT:** 40 LBS.  
**INSTALL TIME**  
 PROFESSIONAL: 30 MINUTES  
 NOVICE (DIY): 60 MINUTES  
**INSTALL NOTES:**  
 - NO DRILLING REQUIRED  
 - LOWER EXHAUST HANGERS  
 - REMOVE EXISTING HARDWARE



**PERIODICALLY CHECK THIS RECEIVER HITCH TO ENSURE THAT ALL FASTENERS ARE TIGHT AND THAT ALL STRUCTURAL COMPONENTS ARE SOUND.**

Curt Manufacturing LLC., warrants this product to be free of defects in material and/or workmanship at the time of retail purchase by the original purchaser. If the product is found to be defective, Curt Manufacturing LLC., may repair or replace the product, at their option, when the product is returned, prepaid, with proof of purchase. Alteration to, misuse of, or improper installation of this product voids the warranty. Curt Manufacturing LLC.'s liability is limited to repair or replacement of products found to be defective, and specifically excludes liability for incidental or consequential loss or damage.

HAVING INSTALLATION QUESTIONS? CALL TECHNICAL SUPPORT AT 1-800-798-0813

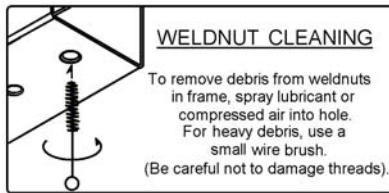

TOOLS REQUIRED
RATCHET
TORQUE WRENCH
8" SOCKET EXTENSION
17mm SOCKET
16mm SOCKET
13mm SOCKET
13mm WRENCH
TORX T25 DRIVER

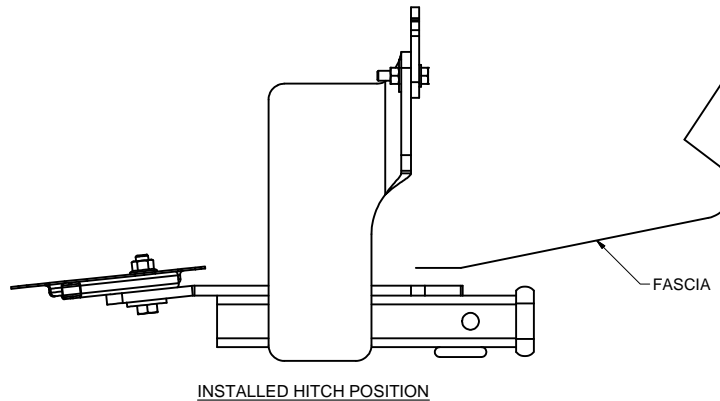

## INSTALLATION STEPS

1. Remove (1) fascia screw per side of vehicle. Middle screw will remain attached. Retain screws for reinstallation.
2. Lower driver and passenger side exhaust hanger by removing (1) nut per hanger. Rotate hanger towards front of vehicle.
3. Remove (2) lower M8 bolts on driver and passenger side bumper brackets. Return hardware to vehicle owner for reinstallation if hitch is removed.
4. Remove (2) M10 bolts attaching reinforcement bars to underside of vehicle trunk pan. Return hardware to vehicle owner for reinstallation if hitch is removed.
5. Install supplied M8 hex bolts and flat washers through threaded holes in bumper brackets where factory M8 hardware was removed in Step 3.
6. Raise hitch into position over installed hardware. Secure hitch with 3/8" conical toothed washers and M8 hex nuts.
7. Install supplied M10 hex bolts and 7/16" conical toothed washers through hitch and existing reinforcement brackets where existing hardware was removed in Step 4.
8. Torque M10 hardware to 38 lb-ft and M8 hardware to 19 lb-ft.
9. Reinstall exhaust hangers.
10. Reinstall fascia screws.

**PERIODICALLY CHECK THIS RECEIVER HITCH TO ENSURE THAT ALL FASTENERS ARE TIGHT AND THAT ALL STRUCTURAL COMPONENTS ARE SOUND.**



Safety glasses should be worn at all times while installing this product.

YEARS: 2012-PRESENT

MAKE: AUDI

MODEL: A7

STYLE: SEDAN

**WARNING: NEVER EXCEED YOUR VEHICLE MANUFACTURER'S RECOMMENDED TOWING CAPACITY**

**WEIGHT CARRYING:**  
 TRAILER WEIGHT: 2,000 LBS.  
 TONGUE WEIGHT: 200 LBS.

**WARNING:**  
 WE RECOMMEND THE USE OF 18050 STABILIZING STRAPS FOR ALL NON-TRAILER (WHEEL-LESS) LOADS. PLEASE SEE THE CURT CATALOG OR VISIT US ONLINE AT [WWW.CURTMFG.COM](http://WWW.CURTMFG.COM) FOR FURTHER INFORMATION.

**INSTALLATION TIME: 30 MIN.**

THE INSTALL TIME LISTED IS FOR PROFESSIONAL INSTALLERS. IF YOU ARE HESITANT TO UNDERTAKE THIS TASK ON YOUR OWN, CONTACT AN AUTHORIZED CURT INSTALLER FOR ADDITIONAL ASSISTANCE.

**INSTALLATION REQUIRES:**

<b>RATCHET</b>	<b>TORQUE WRENCH</b>	<b>8" SOCKET EXTENSION</b>
<b>17mm 16mm 13mm SOCKET</b>	<b>BOXED END WRENCH 13mm</b>	<b>T25 TORXBIT SOCKET</b>
<b>SAFETY GLASSES</b>		

**INSTALLATION TIPS:**

- BEFORE YOU BEGIN INSTALLATION, READ ALL INSTRUCTIONS THOROUGHLY.
- TO EASE INSTALLATION, 2 PEOPLE MAY BE REQUIRED.
- USING PROPER TOOLS WILL GREATLY IMPROVE THE QUALITY OF THE INSTALL AND REDUCE THE TIME REQUIRED.
- NEED HELP OR HAVE SOME QUESTIONS? CALL TECHNICAL SUPPORT AT 800.798.0813

**LEVEL OF DIFFICULTY: EASY**

EASY	MODERATE	CHALLENGING
	NO DRILLING REQUIRED	
	REMOVE EXISTING HARDWARE	
	CLEAN EXISTING WELDNUTS	

**VEHICLE PHOTO:**



REPRESENTATIVE PHOTO

**HITCH ILLUSTRATION:**

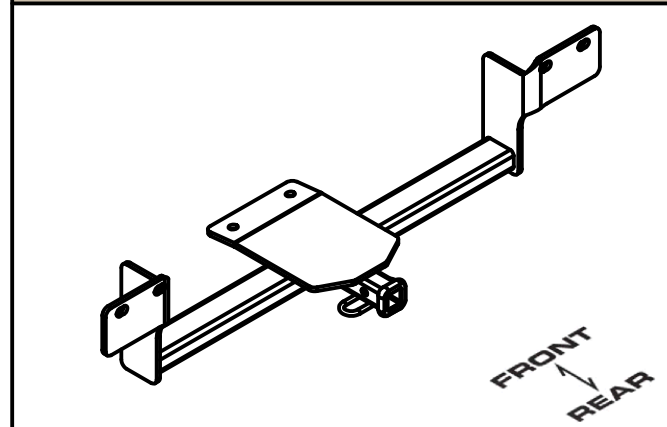

MAKE SURE YOUR HITCH MATCHES

**PERIODICALLY CHECK THIS RECEIVER HITCH TO ENSURE ALL FASTENERS ARE TIGHT AND ALL STRUCTURAL COMPONENTS ARE SOUND**

CURT Manufacturing LLC. warrants this product to be free of defects in material and/or workmanship at the time of retail purchase by the original purchaser. If the product is found to be defective, Curt Manufacturing LLC. may repair or replace the product at their option, when the product is returned, prepaid, with proof of purchase. Alteration to, misuse of, or improper installation of this product voids the warranty. Curt Manufacturing LLC.'s liability is limited to repair or replacement of products found to be defective, and specifically excludes liability for incidental or consequential loss or damage.

For more information log onto [www.curtmfg.com](http://www.curtmfg.com), & for helpful towing tips log onto [www.hitchinfo.com](http://www.hitchinfo.com)

## INSTALLATION WALKTHROUGH:

Parts List			
ITEM	QTY	PART NUMBER	DESCRIPTION
1	2	M10 - 1.5 x 40mm	HEX BOLT
2	2	7/16"	CONICAL TOOTHED WASHER
3	4	M8-1.25 x 35	HEX BOLT
4	4	5/16"	WASHER
5	4	M8-1.25	HEX NUT
6	4	3/8"	CONICAL TOOTHED WASHER

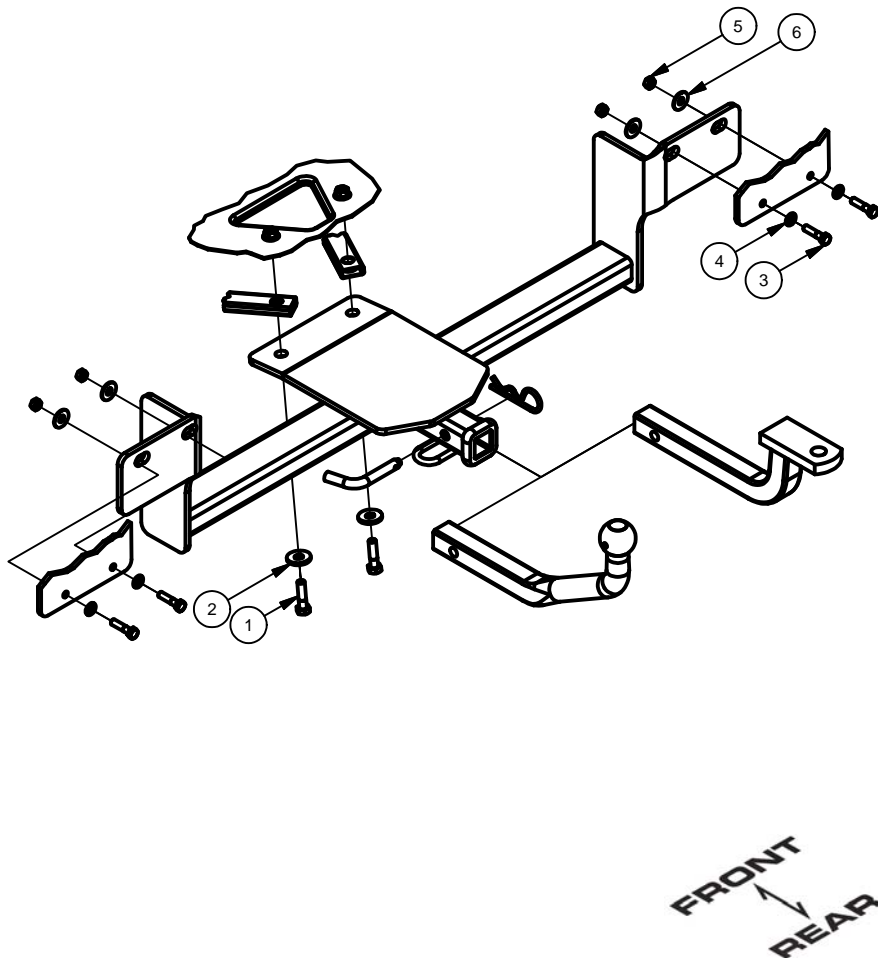

1. Remove (1) fascia screw per side of vehicle. Middle screw will remain attached. Retain screws for reinstallation.



2. Lower driver and passenger side exhaust hanger by removing (1) nut per hanger. Rotate hanger towards front of vehicle.



## INSTALLATION WALKTHROUGH:

3. Remove (2) lower M8 bolts on driver and passenger side bumper brackets. Return hardware to vehicle owner for reinstallation if hitch is removed.



4. Remove (2) M10 bolts attaching reinforcement bars to underside of vehicle trunk pan. Return hardware to vehicle owner for reinstallation if hitch is removed.



5. Install supplied M8 hex bolts and flat washers through threaded holes in bumper brackets where factory M8 hardware was removed in Step 3.



6. Raise hitch into position over installed hardware. Secure hitch with 3/8" conical toothed washers and M8 hex nuts.

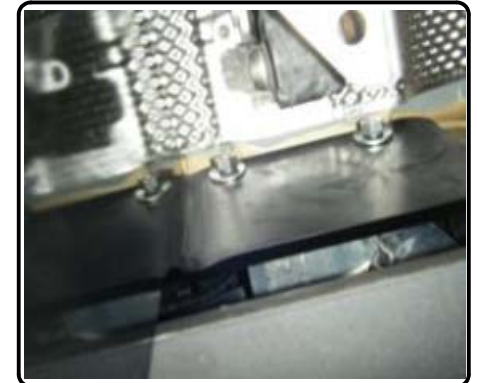
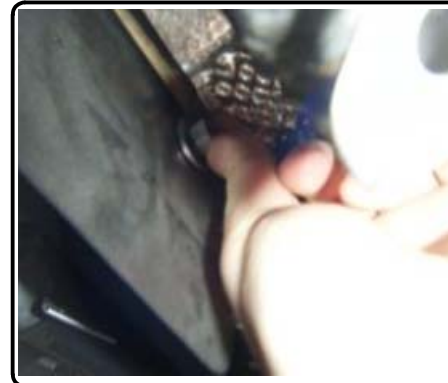

## INSTALLATION WALKTHROUGH:

7. Install supplied M10 hex bolts and 7/16" conical toothed washers through hitch and existing reinforcement brackets where existing hardware was removed in Step 4. Torque M10 hardware to 38 lb-ft and M8 hardware to 19 lb-ft.



8. Reinstall exhaust hangers.



9. Reinstall fascia screws.

