

11472

MAZDA RX8

11/26/2012

GROSS LOAD CAPACITY WHEN USED AS A WEIGHT CARRYING HITCH: 2,000 LBS. TRAILER WEIGHT &amp; 200 LBS. TONGUE WEIGHT.

**\*\*\*DO NOT EXCEED VEHICLE MANUFACTURER'S RECOMMENDED TOWING CAPACITY.\*\*\*****WARNING: ALL NON-TRAILER LOADS APPLIED TO THIS PRODUCT MUST BE SUPPORTED BY 18050 STABILIZING STRAPS.****\*\* FAILURE TO PROPERLY SUPPORT NON-TRAILER LOADS WILL VOID PRODUCT WARRANTY\*\*****HAVING INSTALLATION QUESTIONS? CALL TECHNICAL SUPPORT AT 1-800-798-0813**

Parts List			
ITEM	QTY	PART NUMBER	DESCRIPTION
1	1	CM-.375-FW	FISHWIRE TOOL
2	2	1/2 - 13 x 2"	CARRIAGE BOLT
3	2	HFN 1213	HEX FLANGE NUT
4	1	M6-1.00	HEX NUT
5	2	CM-SP2	.250 x .88 x 2.25" SQUARE HOLE SPACER
6	2	3/8-16 x 1 1/2	CARRIAGE BOLT
7	2	HFN3816	HEX FLANGE NUT
8	1	1_4 LOCK WASHER	1/4" LOCK WASHER
9	1	M6 - 1.00 X 40 TAP BOLT	TAP BOLT
10	1	CM-11472-TPS	.250" x 2.00" TRUNK PAN SUPPORT

**FISHWIRE TECHNIQUE**

INSERT COILED END OF FISHWIRE TOOL THROUGH HITCH MOUNTING HOLE IN VEHICLE FRAME RAIL AND OUT THE ACCESS HOLE. PASS COILED END OF FISHWIRE THROUGH SPACER AND THREAD BOLT INTO COIL. KINK WIRE TO KEEP SPACER SEPERATE FROM BOLT AS SHOWN. PULL FISHWIRE, SPACER, AND BOLT THROUGH FRAME AND OUT MOUNTING HOLE. USE FISHWIRE TO GUIDE HITCH DURING MOUNTING AND PREVENT LOSS OF BOLT / SPACER INSIDE FRAME RAIL.

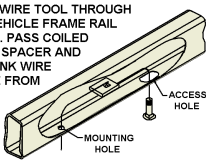

\*\*NOTE: SOME VEHICLES MAY FISHWIRE THROUGH END OF FRAME\*\*

HITCH WEIGHT: 25 LBS.

**INSTALL TIME**

PROFESSIONAL: 60 MINUTES

NOVICE (DIY): 120 MINUTES

**INSTALL NOTES:**

- DRILLING REQUIRED
- FISHWIRE HARDWARE
- SILICONE SEAL HARDWARE

**FRONT**  
↕  
**REAR**

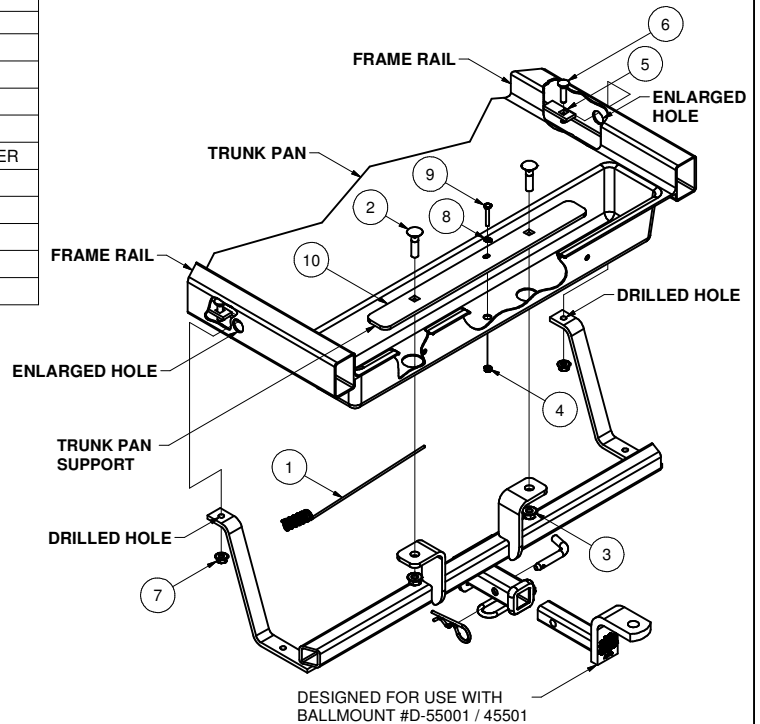
**INSTALLATION STEPS**

1. Remove jack and jack box from trunk by removing (2) plastic fasteners and (1) bolt, reuse later.
2. Remove rubber plugs from under carpet in the trunk pan and from sides of frame rails, discard.
3. Install 1/2" carriage bolts and trunk pan support through trunk as shown
4. Pull heat shield back and raise hitch into position securing with flange nuts.
5. Using the hitch as a template mark and center punch hitch arm holes on the frame rails.
6. Lower hitch and drill center punched holes using a 1/2" drill.
7. Enlarge holes in sides of frame rails to 1".
8. Fishwire 3/8" carriage bolts and spacers through enlarged holes and out drilled holes.
9. Raise hitch into position over carriage bolts and secure with flange nuts as shown.
10. Torque all 1/2" fasteners to 110 lb-ft, all 3/8" fasteners to 45 lb-ft. and all M6 fasteners to 9 lb-ft.
11. Reinstall jack box and jack removed in Step 1.
12. Use silicone sealant to seal hardware installed through trunk pan.

**PERIODICALLY CHECK THIS RECEIVER HITCH TO ENSURE THAT ALL FASTENERS ARE TIGHT AND THAT ALL STRUCTURAL COMPONENTS ARE SOUND.**

Curt Manufacturing Inc., warrants this product to be free of defects in material and/or workmanship at the time of retail purchase by the original purchaser. If the product is found to be defective, Curt Manufacturing Inc., may repair or replace the product, at their option, when the product is returned, prepaid, with proof of purchase. Alteration to, misuse of, or improper installation of this product voids the warranty. Curt Manufacturing Inc.'s liability is limited to repair or replacement of products found to be defective, and specifically excludes liability for incidental or consequential loss or damage.

247472