

11496 ACURA TL AND TSX (INCLUDING SPORT WAGON), HONDA ACCORD

3/18/2011

GROSS LOAD CAPACITY WHEN USED AS A WEIGHT CARRYING HITCH: 2,000 LBS. TRAILER WEIGHT & 200 LBS. TONGUE WEIGHT.

*****DO NOT EXCEED VEHICLE MANUFACTURER'S RECOMMENDED TOWING CAPACITY.*****

WARNING: ALL NON-TRAILER LOADS APPLIED TO THIS PRODUCT MUST BE SUPPORTED BY AUXILIARY STABILIZING STRAPS.

**** FAILURE TO PROPERLY SUPPORT NON-TRAILER LOADS WILL VOID PRODUCT WARRANTY****

HAVING INSTALLATION QUESTIONS? CALL TECHNICAL SUPPORT AT 1-800-798-0813

Parts List			
ITEM	QTY	PART NUMBER	DESCRIPTION
1	2	7/16-14	HEX FLANGE NUT
2	2	7/16-14 x 1 1/2	CARRIAGE BOLT
3	2	CM-SP11	.250 x 1.00 x 2.50" SQUARE HOLE SPACER
4	2	7_16 FISHWIRE	7/16" FISHWIRE
5	2	HFN3816	HEX FLANGE NUT
6	1	3_8 - 16 x 1.00 x 1.88	U-BOLT

HOLE ENLARGEMENT WITH DIE GRINDER / ROTARY TOOL

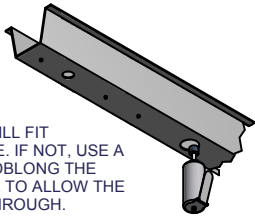
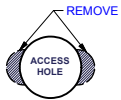

CHECK IF HARDWARE WILL FIT THROUGH ACCESS HOLE. IF NOT, USE A GRINDER / DREMEL TO ENLARGE THE HOLE AS SHOWN ABOVE TO ALLOW THE FASTENERS TO PASS THROUGH.

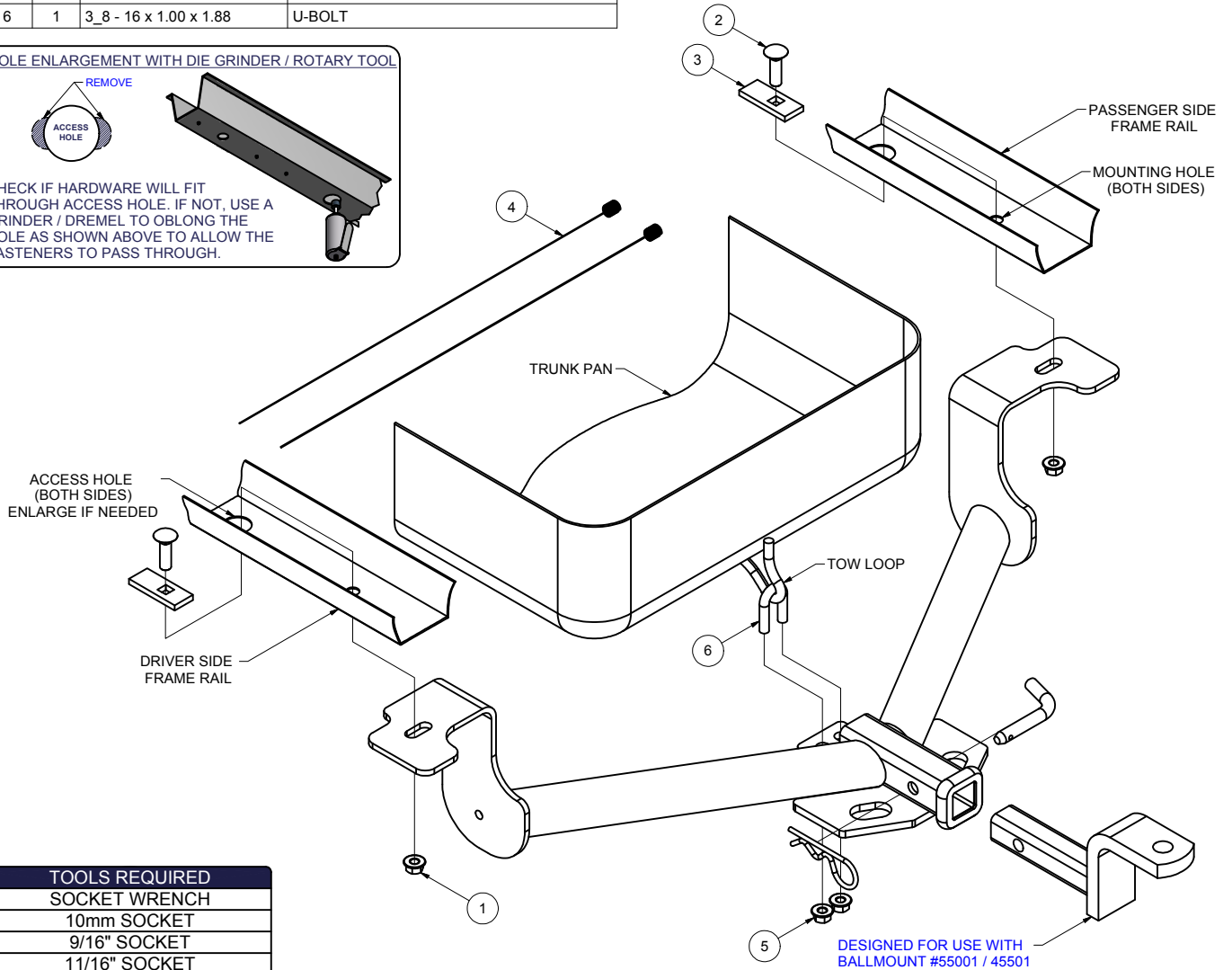

TOOLS REQUIRED
SOCKET WRENCH
10mm SOCKET
9/16" SOCKET
11/16" SOCKET
TORQUE WRENCH
DIE GRINDER/ROTARY TOOL
AVIATION SHEARS

HITCH WEIGHT: 23 LBS.
 INSTALL TIME: 45 MINUTES
 INSTALL NOTES:

- HOLE ENLARGEMENT REQUIRED
- HEAT SHIELD TRIMMING REQUIRED
- FISHWIRE HARDWARE

FISHWIRE TECHNIQUE

INSERT COILED END OF FISHWIRE TOOL THROUGH HITCH MOUNTING HOLE IN VEHICLE FRAME RAIL AND OUT THE ACCESS HOLE. PASS COILED END OF FISHWIRE THROUGH SPACER AND THREAD BOLT INTO COIL. KINK WIRE TO KEEP SPACER SEPARATE FROM BOLT AS SHOWN. PULL FISHWIRE, SPACER, AND BOLT THROUGH FRAME AND OUT MOUNTING HOLE. USE FISHWIRE TO GUIDE HITCH DURING MOUNTING AND PREVENT LOSS OF BOLT / SPACER INSIDE FRAME RAIL.

****NOTE: SOME VEHICLES MAY FISHWIRE THROUGH END OF FRAME****

PERIODICALLY CHECK THIS RECEIVER HITCH TO ENSURE THAT ALL FASTENERS ARE TIGHT AND THAT ALL STRUCTURAL COMPONENTS ARE SOUND.

Curt Manufacturing Inc., warrants this product to be free of defects in material and/or workmanship at the time of retail purchase by the original purchaser. If the product is found to be defective, Curt Manufacturing Inc., may repair or replace the product, at their option, when the product is returned, prepaid, with proof of purchase. Alteration to, misuse of, or improper installation of this product voids the warranty. Curt Manufacturing Inc.'s liability is limited to repair or replacement of products found to be defective, and specifically excludes liability for incidental or consequential loss or damage.

11496 ACURA TL AND TSX (INCLUDING SPORT WAGON), HONDA ACCORD

3/18/2011

GROSS LOAD CAPACITY WHEN USED AS A WEIGHT CARRYING HITCH: 2,000 LBS. TRAILER WEIGHT & 200 LBS. TONGUE WEIGHT.

*****DO NOT EXCEED VEHICLE MANUFACTURER'S RECOMMENDED TOWING CAPACITY.*****

WARNING: ALL NON-TRAILER LOADS APPLIED TO THIS PRODUCT MUST BE SUPPORTED BY AUXILIARY STABILIZING STRAPS.

**** FAILURE TO PROPERLY SUPPORT NON-TRAILER LOADS WILL VOID PRODUCT WARRANTY****

HAVING INSTALLATION QUESTIONS? CALL TECHNICAL SUPPORT AT 1-800-798-0813

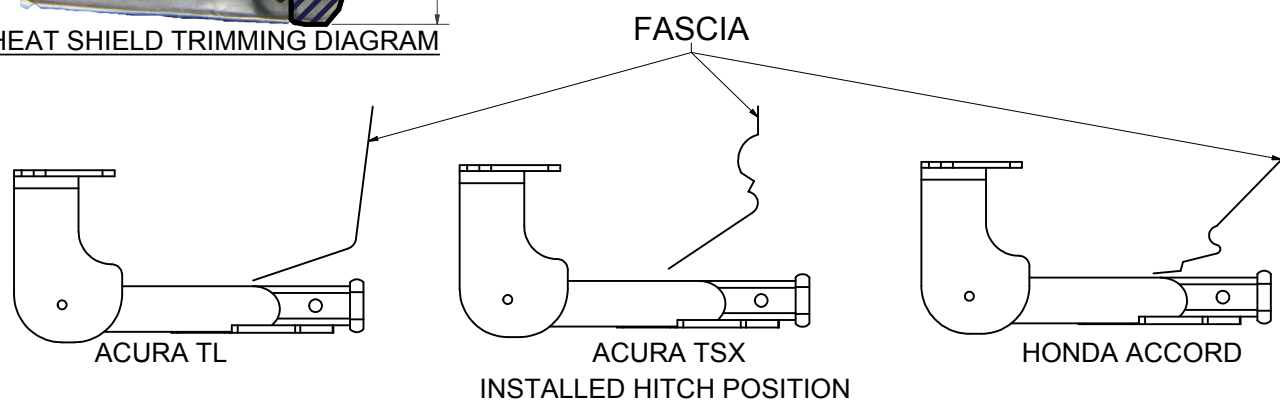
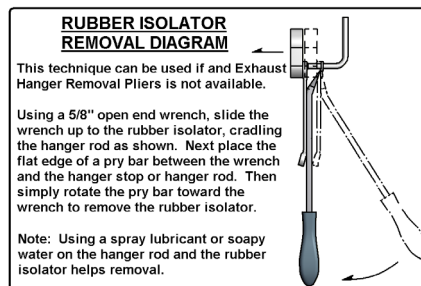
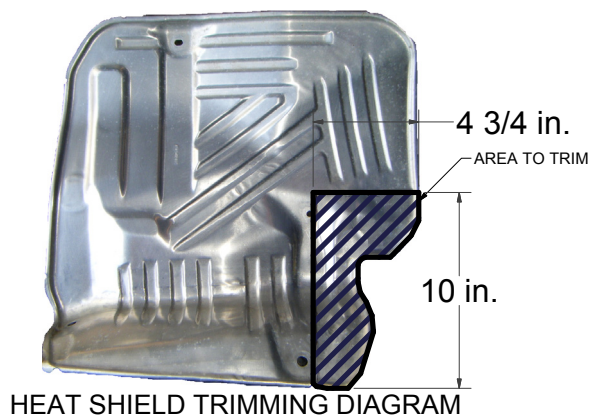

INSTALLATION STEPS

1. Lower exhaust by removing two (2) rubber exhaust isolators for single exhaust vehicles and four (4) isolators for dual exhaust vehicles. (See RUBBER ISOLATOR REMOVAL DIAGRAM.)
2. Remove heat shield(s) by removing four (4) screws per shield. Save screws and shields for reinstallation in Step 8.
3. Check if hardware can be inserted through access holes in frame rails. If not, enlarge the holes with a die grinder or rotary tool until hardware can pass through.
4. Fishwire 7/16-14 x 1 1/2 carriage bolts and CM-SP11 spacers through access holes and out mounting holes in both frame rails, as shown. (See FISHWIRE TECHNIQUE diagram.)
5. Insert 3/8" U-bolt through tow hook as shown.
6. Raise hitch into position and secure it with 7/16-14 hex flange nuts on to carriage bolts and 3/8-16 hex flange nuts on to U-bolt, as shown.
7. Torque all 7/16" hardware to 50 lb-ft and 3/8" hardware to 30 lb-ft.
8. Reinstall heat shields with hardware removed in Step 2. Trim heat shields around hitch. (See HEAT SHIELD TRIMMING DIAGRAM.)
9. Raise exhaust and reattach rubber isolators removed in Step 1.

PERIODICALLY CHECK THIS RECEIVER HITCH TO ENSURE THAT ALL FASTENERS ARE TIGHT AND THAT ALL STRUCTURAL COMPONENTS ARE SOUND.

Curt Manufacturing Inc., warrants this product to be free of defects in material and/or workmanship at the time of retail purchase by the original purchaser. If the product is found to be defective, Curt Manufacturing Inc., may repair or replace the product, at their option, when the product is returned, prepaid, with proof of purchase. Alteration to, misuse of, or improper installation of this product voids the warranty. Curt Manufacturing Inc.'s liability is limited to repair or replacement of products found to be defective, and specifically excludes liability for incidental or consequential loss or damage.