

11647

## 86-89 TOYOTA CELICA HATCHBACK

3/25/2013

GROSS LOAD CAPACITY WHEN USED AS A WEIGHT CARRYING HITCH: 2,000 LBS. TRAILER WEIGHT &amp; 200 LBS. TONGUE WEIGHT.

\*\*\*DO NOT EXCEED VEHICLE MANUFACTURER'S RECOMMENDED TOWING CAPACITY.\*\*\*

WARNING: ALL NON-TRAILER LOADS APPLIED TO THIS PRODUCT MUST BE SUPPORTED BY 18050 STABILIZING STRAPS.

\*\* FAILURE TO PROPERLY SUPPORT NON-TRAILER LOADS WILL VOID PRODUCT WARRANTY\*\*

HAVING INSTALLATION QUESTIONS? CALL TECHNICAL SUPPORT AT 1-800-798-0813

Parts List			
ITEM	QTY	PART NUMBER	DESCRIPTION
1	4	M12 - 1.25 x 40 HEX	HEX BOLT
2	6	1/2"	LOCK WASHER
3	4	7/16 WASHER	WASHER
4	2	M12-1.25 x 30mm	HEX BOLT
5	2	M12 - 1.25 HANDLE-NUT	HANDLE NUT

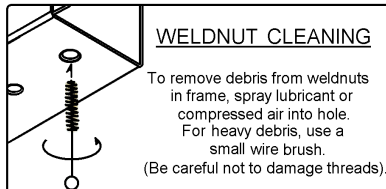

FRONT  
↕  
REAR

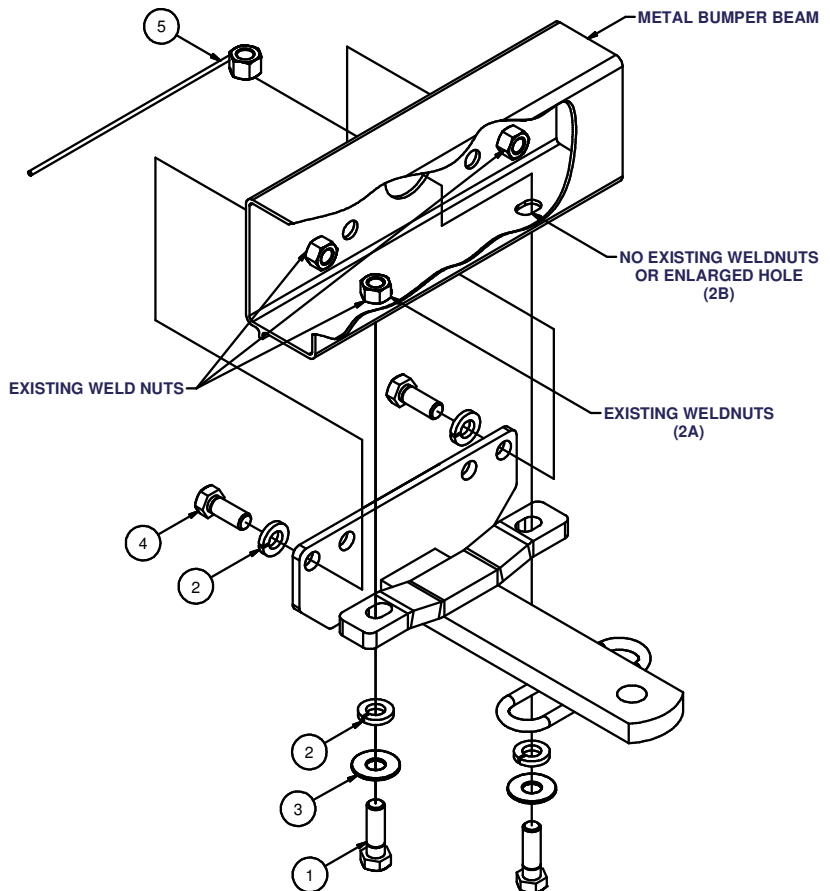

HITCH WEIGHT: 7 LBS.

## INSTALL TIME

PROFESSIONAL: 45 MINUTES

NOVICE (DIY): 90 MINUTES

## INSTALL NOTES:

- FASCIA TRIMMING REQUIRED
- ENLARGE HOLES
- DRILLING REQUIRED

## INSTALLATION STEPS

1. Position the hitch on the bumper so the front bracket holes align with the threaded holes in the front face of the bumper. Mark the metal retainer strip and plastic fascia at the bottom of the bumper. This area (approximately 1 1/2 x 8") must be clear for the bracket to fit directly against the metal bumper. Use a 10mm wrench to remove the retainer from the bumper, and trim marked area.
- 2A. Note the holes in the bottom of the metal bumper that match the holes in the hitch bumper bracket. For those bumpers with match 12mm weldnuts, the hitch can be bolted directly in place using 12mm bolts and washers called out. If the vehicle does not have threaded holes in the bottom surface; go to 2B.
- 2B. Some bumpers will have smaller threaded holes (weldnuts) for the retainer or no holes at all matching the holes in the hitch bracket. Remove the (2) small weld nuts (if any). Use the hitch as a template to drill matching 1/2" diameter holes in the metal bumper. Fasten the hitch at these holes as shown.
3. Torque all 12mm fasteners to 86 lb-ft.

**PERIODICALLY CHECK THIS RECEIVER HITCH TO ENSURE THAT ALL FASTENERS ARE TIGHT AND THAT ALL STRUCTURAL COMPONENTS ARE SOUND.**

Curt Manufacturing Inc., warrants this product to be free of defects in material and/or workmanship at the time of retail purchase by the original purchaser. If the product is found to be defective, Curt Manufacturing Inc., may repair or replace the product, at their option, when the product is returned, prepaid, with proof of purchase. Alteration to, misuse of, or improper installation of this product voids the warranty. Curt Manufacturing Inc.'s liability is limited to repair or replacement of products found to be defective, and specifically excludes liability for incidental or consequential loss or damage.

217383