

GROSS LOAD CAPACITY WHEN USED AS A WEIGHT CARRYING HITCH: 3,500 LBS. TRAILER WEIGHT & 350 LBS. TONGUE WEIGHT.

DO NOT EXCEED VEHICLE MANUFACTURER'S RECOMMENDED TOWING CAPACITY.

WARNING: ALL NON-TRAILER LOADS APPLIED TO THIS PRODUCT MUST BE SUPPORTED BY AUXILIARY STABILIZING STRAPS.

** FAILURE TO PROPERLY SUPPORT NON-TRAILER LOADS WILL VOID PRODUCT WARRANTY**

HAVING INSTALLATION QUESTIONS? CALL TECHNICAL SUPPORT AT 1-800-798-0813

Parts List			
ITEM	QTY	PART NUMBER	DESCRIPTION
1	4	1/2-13 x 1 1/2	CARRIAGE BOLT
2	4	CM-SP6	.250 x 1.00 x 3.00" SQ. HOLE SPACER
3	4	HFN 1213	HEX FLANGE NUT
4	2	1_2 FISHWIRE	1/2" FISHWIRE

TOOLS REQUIRED
10 AND 19mm SOCKETS
8" EXTENSION
RATCHET
TORQUE WRENCH
DRILL AND 17/32" BIT
ROTARY TOOL / CARBIDE BIT
TIN SNIPS / FILE

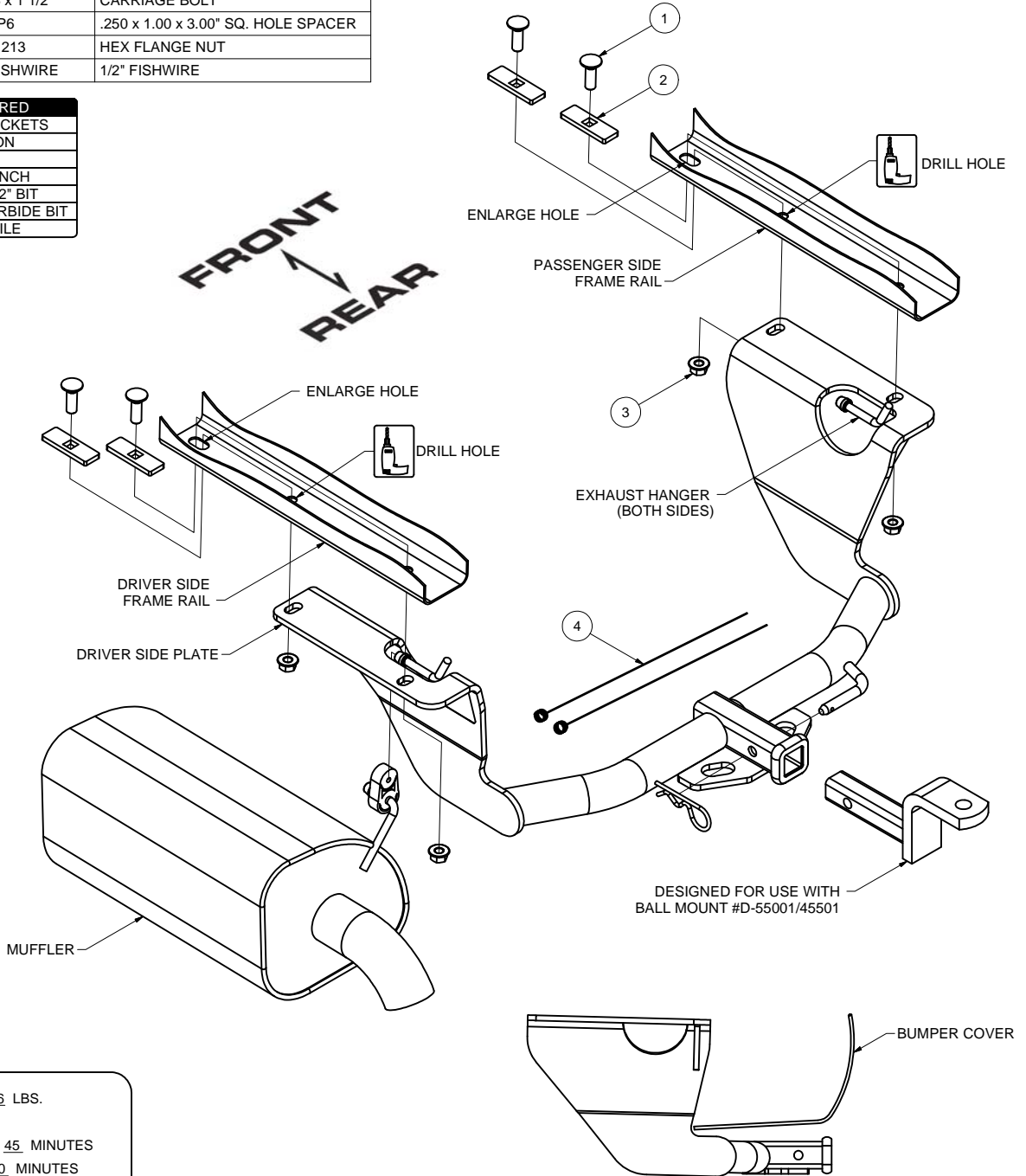

HITCH WEIGHT: .36 LBS.
 INSTALL TIME
 PROFESSIONAL: .45 MINUTES
 NOVICE (DIY): .90 MINUTES
 INSTALL NOTES:
 - DRILLING REQUIRED
 - FISHWIRE HARDWARE

PERIODICALLY CHECK THIS RECEIVER HITCH TO ENSURE THAT ALL FASTENERS ARE TIGHT AND THAT ALL STRUCTURAL COMPONENTS ARE SOUND.

Curt Manufacturing Inc., warrants this product to be free of defects in material and/or workmanship at the time of retail purchase by the original purchaser. If the product is found to be defective, Curt Manufacturing Inc., may repair or replace the product, at their option, when the product is returned, prepaid, with proof of purchase. Alteration to, misuse of, or improper installation of this product voids the warranty. Curt Manufacturing Inc.'s liability is limited to repair or replacement of products found to be defective, and specifically excludes liability for incidental or consequential loss or damage.

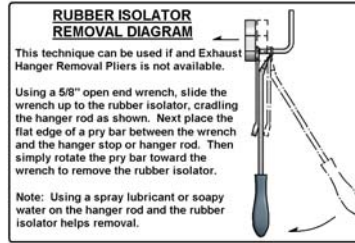
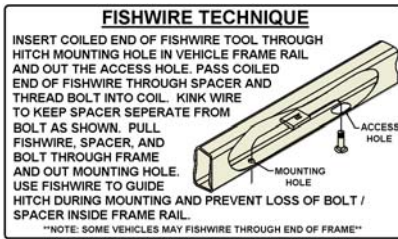

HEAT SHIELD TRIM DIAGRAM

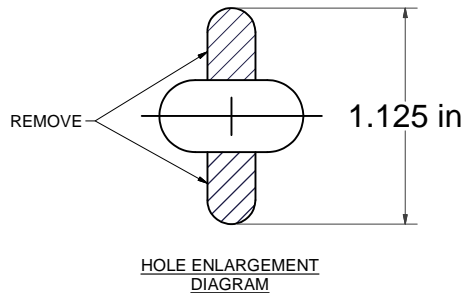

INSTALLATION STEPS

1. Lower the exhaust by removing the (3) rearmost rubber exhaust isolators from the frame mounted hangers. Note: Support the exhaust during installation to prevent damage. (See Rubber Isolator Removal Diagram.)
2. Remove the muffler heat shield and trim to clear the mounting plate. (See Heat Shield Trim Diagram.)
3. Remove the (2) rubber plugs in each frame rail. Enlarge the forwardmost hole on each frame rail to allow the carriage bolt and spacer to be inserted into the frame rail. (See Hole Enlargement Diagram.)
4. Fishwire a carriage bolt and spacer into the rearmost hole in each frame rail as shown. (See Fishwire Hardware Technique.)
5. Raise the hitch into position, taking care not to push the fishwired hardware into the frame rails. Center the hitch on the vehicle and loosely secure the hitch to the vehicle with hex flange nuts as shown.
6. Mark and drill the forwardmost holes in the frame rail using the hitch as your template.
7. Fishwire a carriage bolt and spacer into each drilled hole and secure the hitch with a hex flange nuts as shown.
8. Torque all hardware to 75 ft-lbs.
9. Reinstall the heat shield, raise the exhaust and reinstall the rubber isolators.

PERIODICALLY CHECK THIS RECEIVER HITCH TO ENSURE THAT ALL FASTENERS ARE TIGHT AND THAT ALL STRUCTURAL COMPONENTS ARE SOUND.