



# 13155 INSTALLATION INSTRUCTIONS



Safety glasses should be worn at all times while installing this product.

YEARS: 2013

MAKE: MERCEDES BENZ

MODEL: GLK250 BLUETEC

STYLE: SUV

**WARNING: NEVER EXCEED YOUR VEHICLE MANUFACTURER'S RECOMMENDED TOWING CAPACITY**

**WEIGHT CARRYING:**  
TRAILER WEIGHT: 3,500 LBS.  
TONGUE WEIGHT: 525 LBS.

**WARNING:**  
WE RECOMMEND THE USE OF 18050 STABILIZING STRAPS FOR ALL NON-TRAILER (WHEEL-LESS) LOADS. PLEASE SEE THE CURT CATALOG OR VISIT US ONLINE AT [WWW.CURTMFG.COM](http://WWW.CURTMFG.COM) FOR FURTHER INFORMATION.

## INSTALLATION TIME: 45/90 MIN.

THE INSTALL TIME LISTED IS FOR PROFESSIONAL/NOVICE INSTALLERS. IF YOU ARE HESITANT TO UNDERTAKE THIS TASK ON YOUR OWN, CONTACT AN AUTHORIZED CURT INSTALLER FOR ADDITIONAL ASSISTANCE.

## INSTALLATION TIPS:

1. BEFORE YOU BEGIN INSTALLATION, READ ALL INSTRUCTIONS THOROUGHLY.
2. TO EASE INSTALLATION, 2 PEOPLE MAY BE REQUIRED.
3. USING PROPER TOOLS WILL GREATLY IMPROVE THE QUALITY OF THE INSTALL AND REDUCE THE TIME REQUIRED.
4. NEED HELP OR HAVE SOME QUESTIONS? CALL TECHNICAL SUPPORT AT 800.798.0813

## INSTALLATION REQUIRES:

 SAFETY GLASSES	 RATCHET	 T40 TORXBIT SOCKET
 6" SOCKET EXTENSION	 SCREW DRIVER	 WIRE PIPE BRUSH
 DRILL BIT 1/2"	 POWER DRILL	 DIE GRINDER
 3/4" 1 1/16" SOCKET	 TORQUE WRENCH	

## LEVEL OF DIFFICULTY: MODERATE

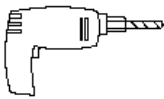
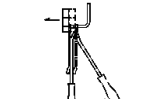
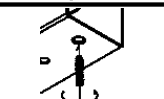
EASY	MODERATE	HARD
	- ENLARGE HOLES	
	- LOWER EXHAUST	
	- WELDNUT CLEANING	

## VEHICLE PHOTO:



REPRESENTATIVE PHOTO

## HITCH ILLUSTRATION:

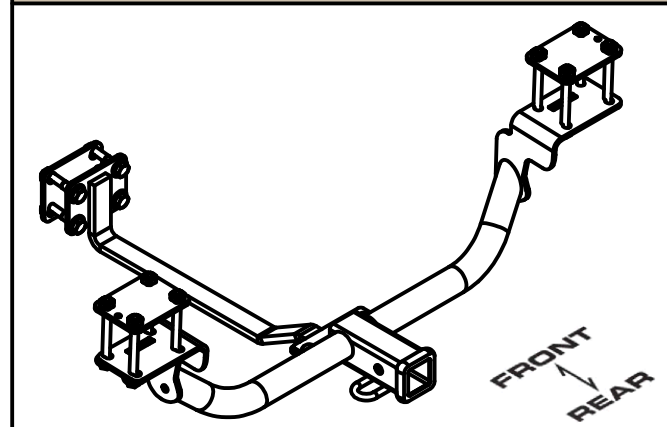

MAKE SURE YOUR HITCH MATCHES

**PERIODICALLY CHECK THIS RECEIVER HITCH TO ENSURE ALL FASTENERS ARE TIGHT AND ALL STRUCTURAL COMPONENTS ARE SOUND**

CURT Manufacturing Inc. warrants this product to be free of defects in material and/or workmanship at the time of retail purchase by the original purchaser. If the product is found to be defective, Curt Manufacturing Inc. may repair or replace the product at their option, when the product is returned, prepaid, with proof of purchase. Alteration to, misuse of, or improper installation of this product voids the warranty. Curt Manufacturing Inc.'s liability is limited to repair or replacement of products found to be defective, and specifically excludes liability for incidental or consequential loss or damage.

For more information log onto [www.curtmfg.com](http://www.curtmfg.com), & for helpful towing tips log onto [www.hitchinfo.com](http://www.hitchinfo.com)

## INSTALLATION WALKTHROUGH:

Parts List			
ITEM	QTY	PART NUMBER	DESCRIPTION
1	3	CM-NP1W	NUT PLATE WELDMNT
2	8	1_2 - 13 x 5 HEX	HEX BOLT
3	2	7/16-14	HEX FLANGE NUT
4	4	1/2 - 13 x 2 3/4	HEX BOLT
5	12	1/2"	CONICAL TOOTHED WASHER
6	2	7/16-14 x 1	CARRIAGE BOLT

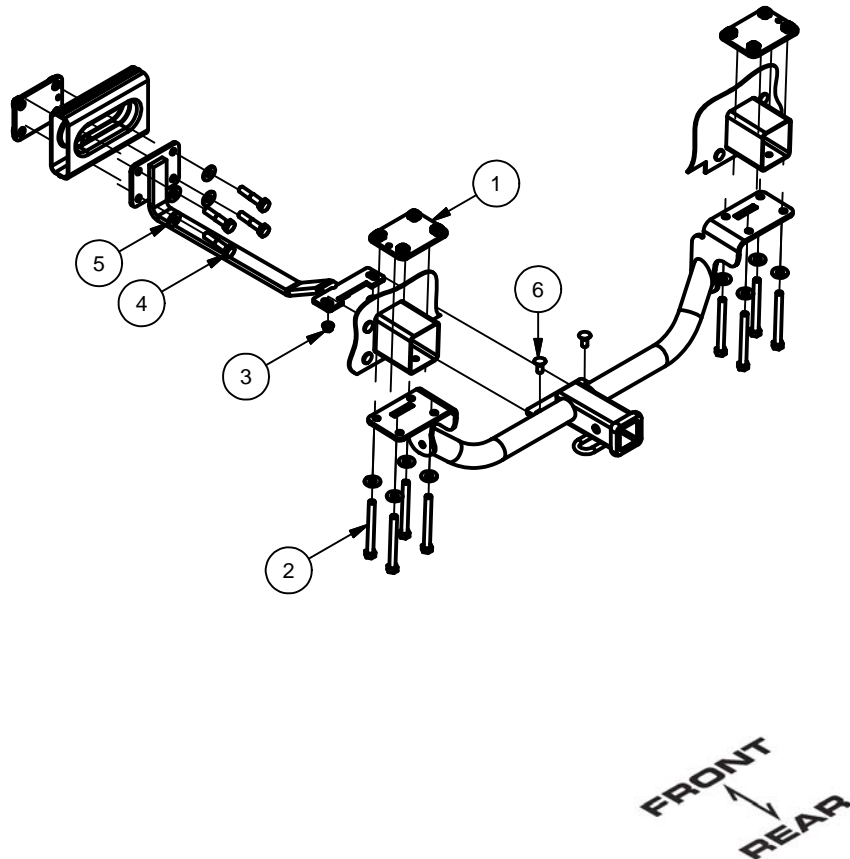

1. Remove 3 fascia clips from each side of the vehicle with a flat head screwdriver. This will allow for the fascia to flex slightly for socket access during installation.



2. Remove exhaust tips by removing T40 torx screws from 3 locations on each side of the vehicle with a short torx bit and ratchet extension. Tips will be reinstated when hitch installation is complete.

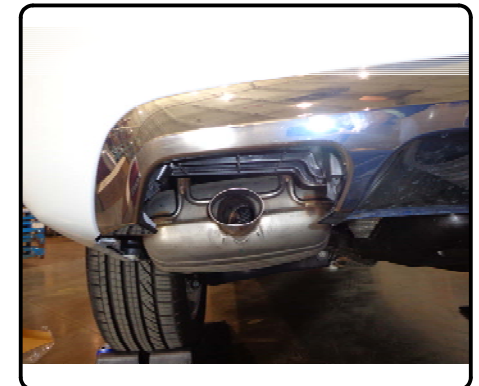

## INSTALLATION WALKTHROUGH:

3. Lower exhaust by removing (2) isolators on the driver side muffler, (2) isolators on the passenger side muffler, and (2) isolators forward of the mufflers. Note: Exhaust can pivot on driver side at ball joint location for increased access to rear vehicle mounting location.

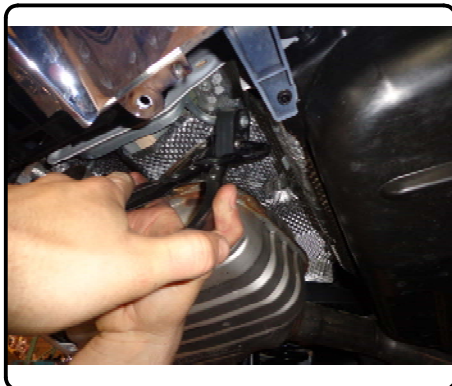

4. Locate plastic fascia support webbing and drill out center inboard section. Enlarge section for 3/4" socket access in order to tighten hitch to nut plates over bumper beam.



5. Locate supplied nut plates from hitch and hardware assembly. Nut plate weldnut threads may need to be cleaned with a wire brush before assembly.

6. Place supplied nut plates over bumper beam, as shown.



7. Raise hitch into position over exhaust.

8. Secure hitch to nut plates, with finger tightened 1/2" x 5" hex bolts and 1/2" conical toothed washers, as shown. (Note: Be sure to slide hitch as far forward as possible but not so it rests on the weld seam on the vehicle bumper beams.)

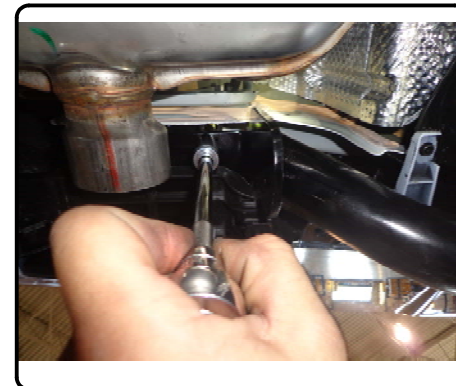

## INSTALLATION WALKTHROUGH:

9. Raise mounting strap behind vehicle crossmember, as shown.
10. Secure mounting strap to hitch with finger tightened 7/16" hex flange nuts.



11. Raise nut plate in front of vehicle cross member.
12. Secure nut plate to mounting strap with finger tightened 1/2" x 2 3/4" hex bolts and 1/2" conical toothed washers.



13. Torque all 1/2" hardware to 110 lb-ft and all 7/16" hardware to 70 lb-ft.
14. Raise exhaust back into position.



15. Reattach exhaust tip (3 mounting locations each side.)
16. Reattach fascia clips (3 locations each side of vehicle.)

Installation is complete.

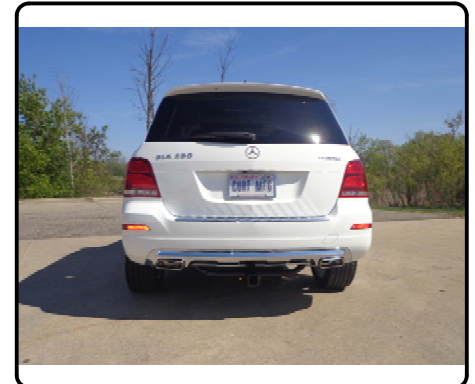

GROSS LOAD CAPACITY WHEN USED AS A WEIGHT CARRYING HITCH: 3,500 LBS. TRAILER WEIGHT & 525 LBS. TONGUE WEIGHT.

\*\*\*DO NOT EXCEED VEHICLE MANUFACTURER'S RECOMMENDED TOWING CAPACITY.\*\*\*

WARNING: ALL NON-TRAILER LOADS APPLIED TO THIS PRODUCT MUST BE SUPPORTED BY AUXILIARY STABILIZING STRAPS.

\*\* FAILURE TO PROPERLY SUPPORT NON-TRAILER LOADS WILL VOID PRODUCT WARRANTY\*\*

HAVING INSTALLATION QUESTIONS? CALL TECHNICAL SUPPORT AT 1-800-798-0813

Parts List			
ITEM	QTY	PART NUMBER	DESCRIPTION
1	12	1/2"	CONICAL TOOTHED WASHER
2	2	7/16-14	HEX FLANGE NUT
3	8	1_2 - 13 x 5 HEX	HEX BOLT
4	2	7/16-14 x 1	CARRIAGE BOLT
5	4	1/2 - 13 x 2 3/4	HEX BOLT
6	3	CM-NP1W	NUT PLATE WELDMENT

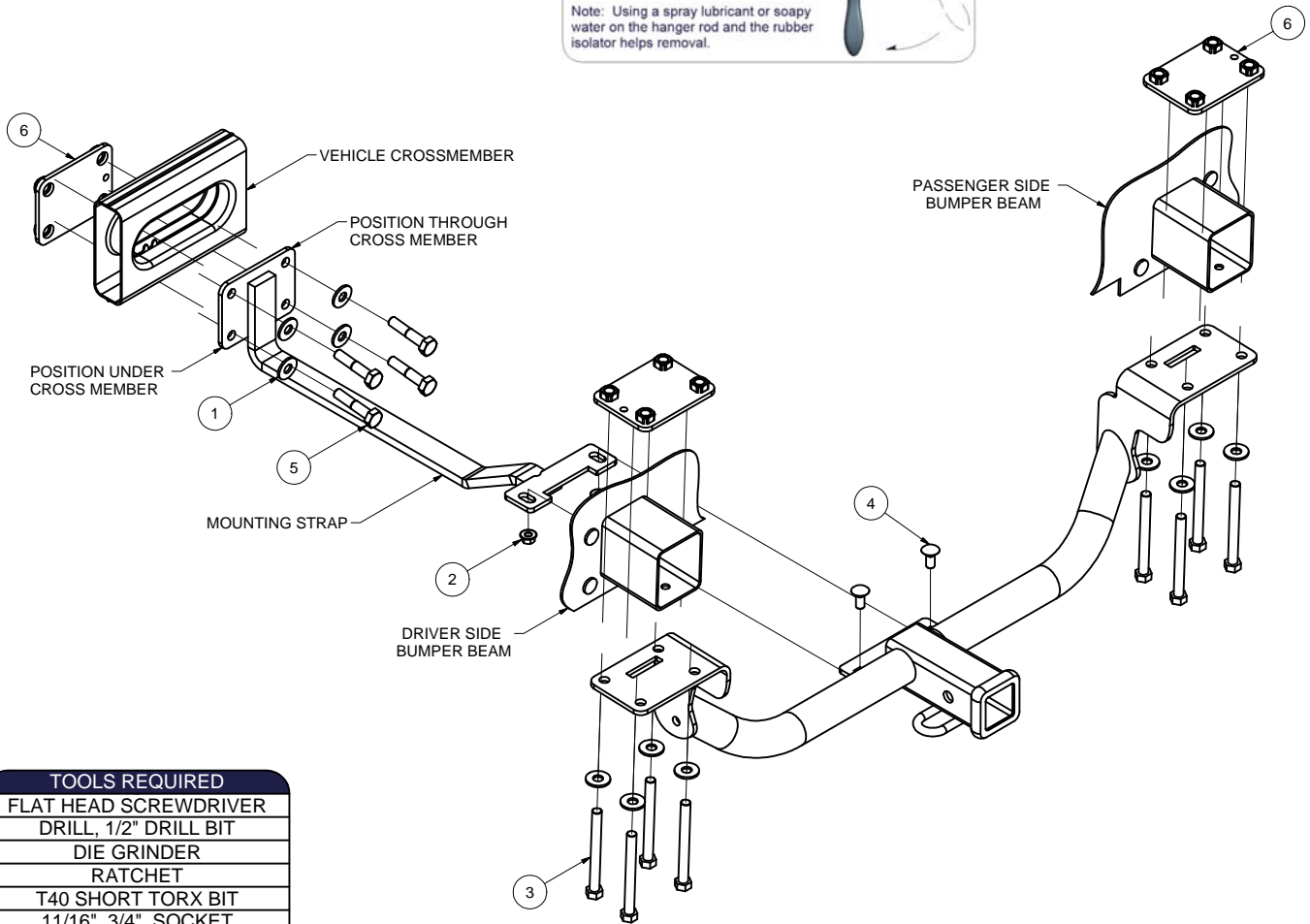
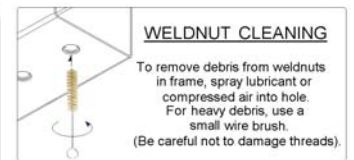
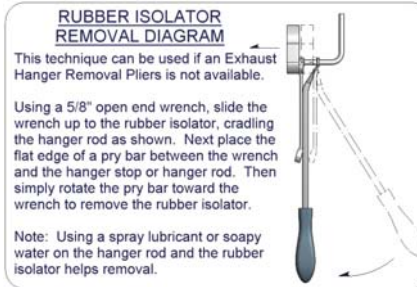

- TOOLS REQUIRED**
- FLAT HEAD SCREWDRIVER
  - DRILL, 1/2" DRILL BIT
  - DIE GRINDER
  - RATCHET
  - T40 SHORT TORX BIT
  - 11/16", 3/4" SOCKET
  - WIRE BRUSH
  - 6" SOCKET EXTENSION
  - TORQUE WRENCH

- HITCH WEIGHT:** .33 LBS.
- INSTALL TIME**
- PROFESSIONAL: 45 MINUTES
  - NOVICE (DIY): 90 MINUTES
- INSTALL NOTES:**
- LOWER EXHAUST
  - FISHWIRE HARDWARE

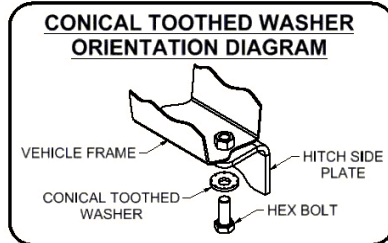

PERIODICALLY CHECK THIS RECEIVER HITCH TO ENSURE THAT ALL FASTENERS ARE TIGHT AND THAT ALL STRUCTURAL COMPONENTS ARE SOUND.

Curt Manufacturing Inc., warrants this product to be free of defects in material and/or workmanship at the time of retail purchase by the original purchaser. If the product is found to be defective, Curt Manufacturing Inc., may repair or replace the product, at their option, when the product is returned, prepaid, with proof of purchase. Alteration to, misuse of, or improper installation of this product voids the warranty. Curt Manufacturing Inc.'s liability is limited to repair or replacement of products found to be defective, and specifically excludes liability for incidental or consequential loss or damage.

GROSS LOAD CAPACITY WHEN USED AS A WEIGHT CARRYING HITCH: 3,500 LBS. TRAILER WEIGHT & 525 LBS. TONGUE WEIGHT.

\*\*\*DO NOT EXCEED VEHICLE MANUFACTURER'S RECOMMENDED TOWING CAPACITY.\*\*\*

WARNING: ALL NON-TRAILER LOADS APPLIED TO THIS PRODUCT MUST BE SUPPORTED BY AUXILIARY STABILIZING STRAPS.

\*\* FAILURE TO PROPERLY SUPPORT NON-TRAILER LOADS WILL VOID PRODUCT WARRANTY\*\*

HAVING INSTALLATION QUESTIONS? CALL TECHNICAL SUPPORT AT 1-800-798-0813

## INSTALLATION STEPS

1. Remove 3 fascia clips from each side of the vehicle with a flat head screwdriver. This will allow the fascia to flex slightly for socket access during installation.
2. Remove exhaust tips by removing T40 torx screws from 3 locations on each side of the vehicle with a short torx bit and ratchet extension. Tips will be reinstalled when hitch installation is complete.
3. Lower exhaust by removing (2) isolators on the driver side muffler, (2) isolators on the passenger side muffler, and (2) isolators forward of the mufflers.  
(See RUBBER ISOLATOR REMOVAL DIAGRAM.)  
Note: Exhaust can pivot on driver side at ball joint location for increased access to rear vehicle mounting location.
4. Locate plastic fascia support webbing and drill out center inboard section. Enlarge section for 3/4" socket access in order to tighten hitch to nut plates over bumper beam.
5. Locate supplied nut plates from hitch and hardware assembly. Nut plate weldnut threads may need to be cleaned with a wire brush before assembly. (See WELDNUT CLEANING DIAGRAM.)
6. Place supplied nut plates over bumper beam, as shown.
7. Raise hitch into position over exhaust.
8. Secure hitch to nut plates, with finger tightened 1/2" x 5" hex bolts and 1/2" conical toothed washers, as shown. (Note: Be sure to slide hitch as far forward as possible but not so it rests on the weld seam on the vehicle bumper beams.)
9. Raise mounting strap behind vehicle crossmember, as shown.
10. Secure mounting strap to hitch with finger tightened 7/16" hex flange nuts, as shown.
11. Raise nut plate in front of vehicle crossmember.
12. Secure nut plate to mounting strap with finger tightened 1/2" x 2 3/4" hex bolts and 1/2" conical toothed washers, as shown.
13. Torque all 1/2" hardware to 110 lb-ft and all 7/16" hardware to 70 lb-ft.
14. Raise exhaust back into position.
15. Reattach fascia screws (3 locations each side of vehicle.)
16. Reattach exhaust tips (3 mounting locations each side of vehicle.)

**PERIODICALLY CHECK THIS RECEIVER HITCH TO ENSURE THAT ALL FASTENERS ARE TIGHT AND THAT ALL STRUCTURAL COMPONENTS ARE SOUND.**