

13358

SPRINTER 2500 & 3500 CARGO VAN W/ FACTORY STEP BUMPER 144" & 170" WHEEL BASE (EXCEPT 3500 144")

9/10/2012

GROSS LOAD CAPACITY WHEN USED AS A WEIGHT CARRYING HITCH: 5,000 LBS. TRAILER WEIGHT & 500 LBS. TONGUE WEIGHT.
GROSS LOAD CAPACITY WHEN USED AS A WEIGHT DISTRIBUTION HITCH: 7,500 LBS. TRAILER WEIGHT & 750 LBS. TONGUE WEIGHT

***** DO NOT EXCEED VEHICLE MANUFACTURER'S RECOMMENDED TOWING CAPACITY.*****

Parts List			
ITEM	QTY	PART NUMBER	DESCRIPTION
1	2	CM-SP56	.375 x 1.25 x 2.00" ROUND HOLE SPACER
2	2	M12 - 1.75 x 120 HEX	HEX BOLT
3	2	M12-1.75	HEX FLANGE NUT

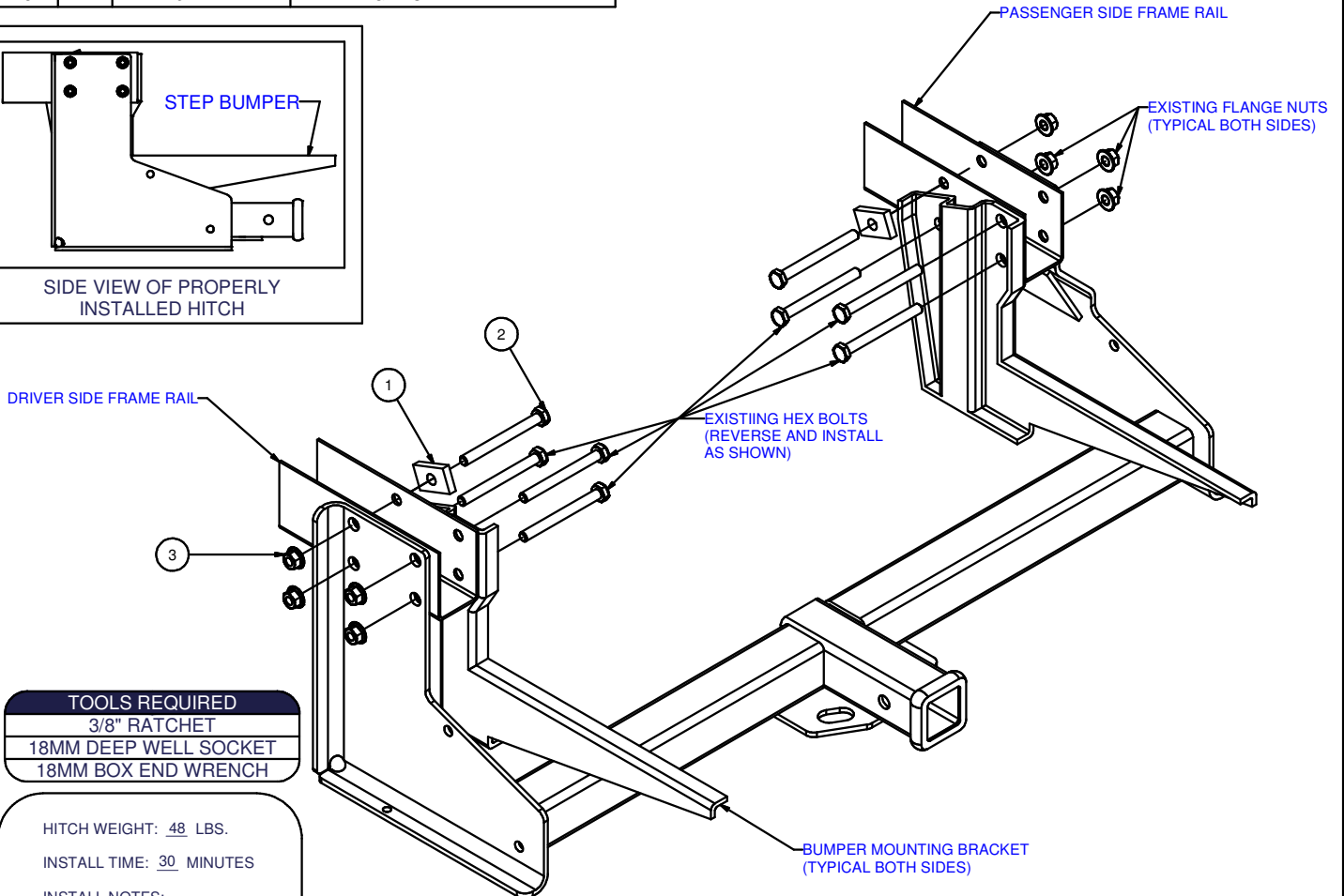
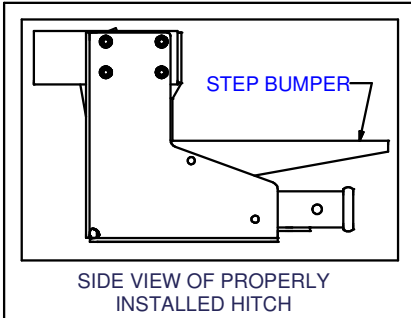

TOOLS REQUIRED

3/8" RATCHET
18MM DEEP WELL SOCKET
18MM BOX END WRENCH

HITCH WEIGHT: 48 LBS.

INSTALL TIME: 30 MINUTES

INSTALL NOTES:

- NO DRILLING REQUIRED

INSTALLATION STEPS

1) Remove all existing nuts from bumper mounting bracket bolts.(3 per side) **Note:** Only remove nuts at this time. Removal of all bolts and nuts at the same time will cause the step bumper to fall and possibly cause step bumper and personal injury.

2) One at a time, remove bolt and reverse placement, inserting bolt from inside of frame outward. Push bolt into bumper mounting bracket hole and three-quarters of the way through frame. Repeat this for all existing bolts.

3) Place hardware provided into existing holes as shown.

4) Raise hitch into position aligning holes as shown. Push the remainder of each bolt through holes and fasten using nuts.

5) Torque all M12 fasteners to 79 lb-ft.

**PERIODICALLY CHECK THIS RECEIVER HITCH TO ENSURE THAT ALL FASTENERS
ARE TIGHT AND THAT ALL STRUCTURAL COMPONENTS ARE SOUND.**

Curt Manufacturing Inc., warrants this product to be free of defects in material and/or workmanship at the time of retail purchase by the original purchaser. If the product is found to be defective, Curt Manufacturing Inc., may repair or replace the product, at their option, when the product is returned, prepaid, with proof of purchase. Alteration to, misuse of, or improper installation of this product voids the warranty. Curt Manufacturing Inc.'s liability is limited to repair or replacement of products found to be defective, and specifically excludes liability for incidental or consequential loss or damage.