

# INSTALLATION MANUAL

13459

## Level of Difficulty

Difficult

Installation difficulty levels are based on time and effort involved and may vary depending on the installer level of expertise, condition of the vehicle and proper tools and equipment.

## Weight Carrying Capacity

Gross trailer weight (GTW)	3,500 lbs.
Tongue weight (TW)	350 lbs.

## Parts List

Item	Qty	Description
1	4	Hex bolt, M10 x 1.25 x 40mm
2	2	Flange nut, M10 x 1.25
3	4	Conical tooth washer, 7/16"
4	2	Carriage bolt, 1/2" - 13 x 2"
5	2	Round hole washer, 2" x 1-1/2" x 1/2"
6	2	Square hole washer, 1/4" x 1" x 2.5"
7	2	Flange nut, 1/2" - 13
8	2	Fishwire, 1/2"

## Tools Required

Ratchet	Flathead screwdriver
Torque wrench	Phillips screwdriver
Socket, 3/4"	Socket extension, 6"
Socket, 14mm	Metal snips
Socket, 17mm	Safety glasses

\* For a tools reference guide visit [curtmfg.com/trailer-hitch-installation](http://curtmfg.com/trailer-hitch-installation)

## ⚠ WARNING

Never exceed the vehicle manufacturer's recommended towing capacity.

## Product Photo



## NOTICE

Visit [www.curtmfg.com](http://www.curtmfg.com) for a full-color copy of this instruction manual, as well as helpful videos, guides and much more!

Before you begin installation, read all instructions thoroughly.

Proper tools will improve the quality of installation and reduce the time required.

This installation requires:

- Trimming of the rear bumper panel
- Removal and reinstallation of the rear bumper cover

Periodic inspection of the trailer hitch should be performed to ensure all mounting hardware remains tight and structural components are secure.

To help prevent damage to the product or vehicle, refer to the specified torque specifications when securing hardware during the installation process.

## SAFETY INSTRUCTIONS

Safety glasses should be worn at all times while installing this product.

## Product Registration and Warranty

CURT stands behind our products with industry-leading warranties. To get copies of the product warranties, register your purchase or provide feedback, visit: [warranty.curtgroup.com/surveys](http://warranty.curtgroup.com/surveys)

# ASSEMBLY

## Parts List

Item	Qty	Description
1	4	Hex bolt, M10 x 1.25 x 40mm
2	2	Flange nut, M10 x 1.25
3	4	Conical tooth washer, 7/16"
4	2	Carriage bolt, 1/2" - 13 x 2"
5	2	Round hole washer, 2" x 1-1/2" x 1/2"
6	2	Square hole washer, 1/4" x 1" x 2.5"
7	2	Flange nut, 1/2" - 13
8	2	Fishwire, 1/2"

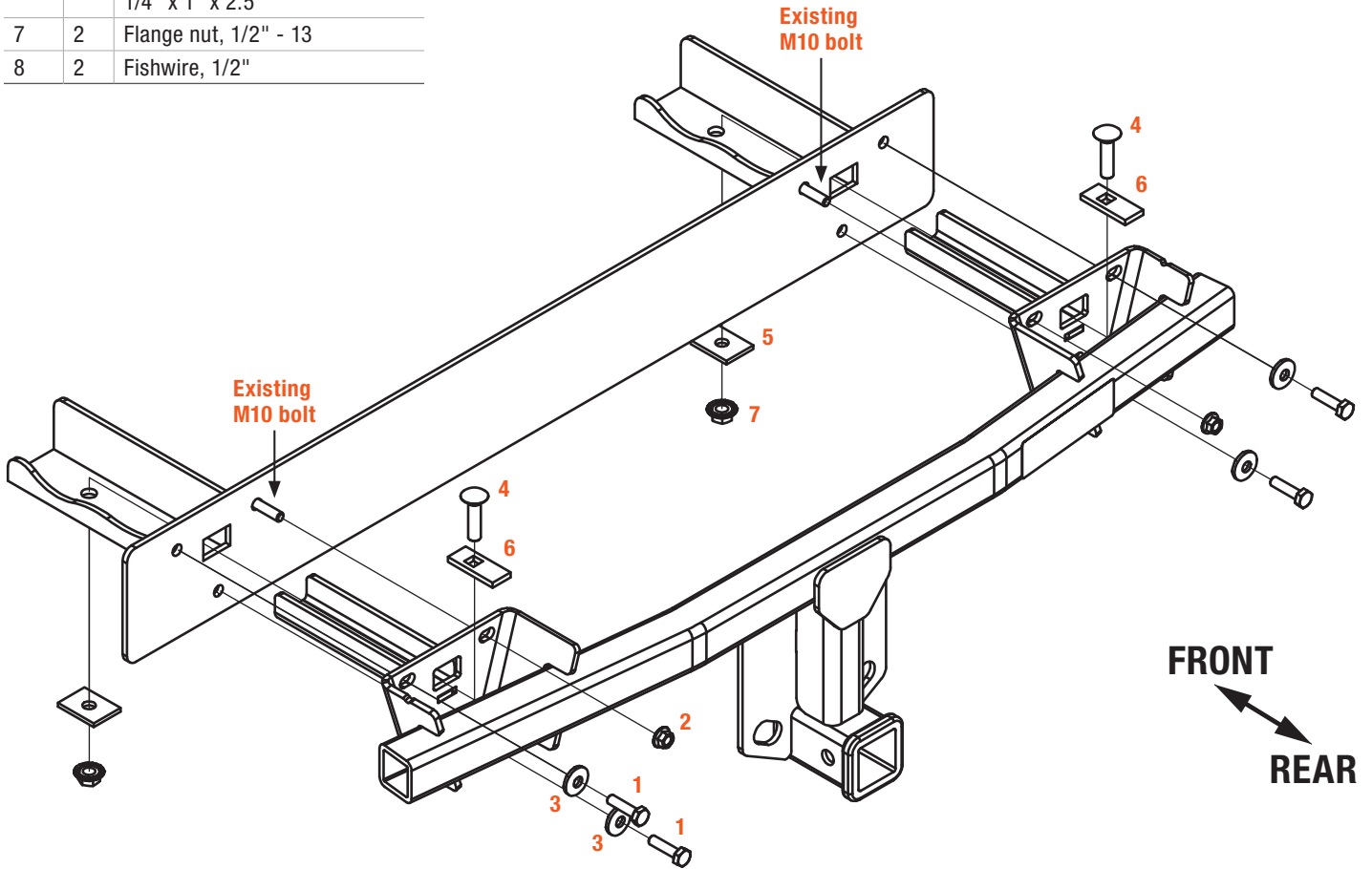

### RUBBER ISOLATOR REMOVAL DIAGRAM

This technique can be used if exhaust hanger removal pliers are not available.

Using a 5/8" open end wrench, slide the wrench up to the rubber isolator, cradling the hanger rod as shown.

Place the flat edge of a pry bar between the wrench and the hanger stop or hanger rod. Then simply rotate the pry bar toward the wrench to remove the rubber isolator.

**Note:** Using a lubricant or soapy water on the hanger rod and the rubber isolator helps removal.

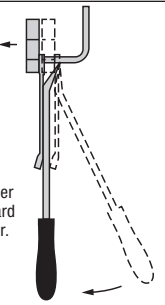

### FISHWIRE TECHNIQUE

Insert coiled end of fishwire tool through hitch mounting hole in vehicle frame rail and out the access hole. Pass coiled end of fishwire through spacer and thread bolt into coil. Kink wire to keep spacer separate from bolt as shown. Pull fishwire, spacer and bolt through frame and out mounting hole. Use fishwire to guide hitch during mounting and prevent loss of bolt or spacer inside frame rail.

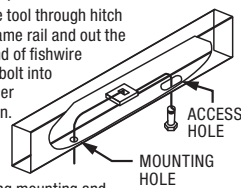

### CONICAL TOOTHED WASHER ORIENTATION

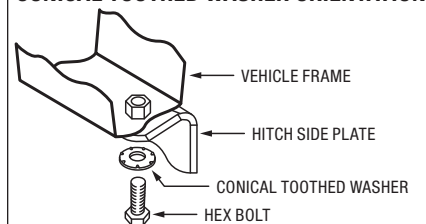

### Step 1

Open the trunk and remove the taillight cover on the passenger side of the vehicle using a Philips screwdriver to remove the two retainers.

Repeat on the driver side.

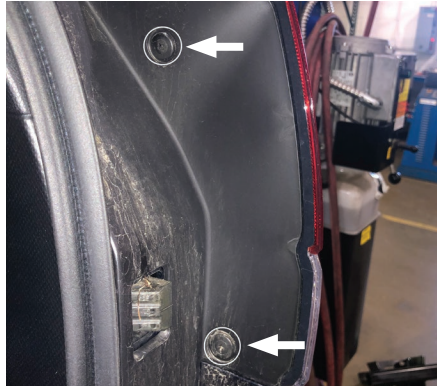

### Step 2

On both sides of the vehicle, unplug the taillight connectors and remove the taillight bracket bolts. Remove the taillights and set aside.

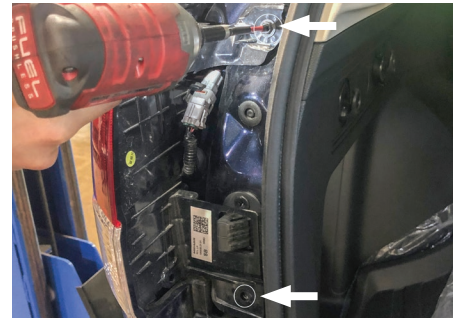

### Step 3

Using a flathead screwdriver, remove the seven plastic rivets in the fascia panel as shown.

Remove one plastic rivet from the wheel well on each side of the vehicle. **Note:** Some trim levels may have three rivets on each side.

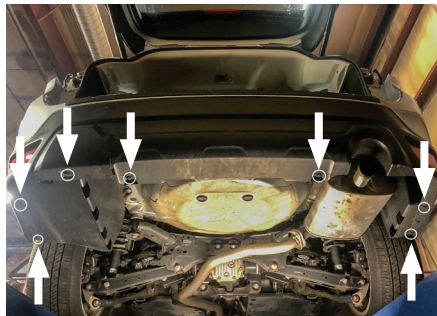



#### Step 4

Gently pull the fascia up from the rear wheel trim panel on each side of the vehicle. Work up to the taillights and continue to remove the fascia along the bottom of the taillights to the bottom of the trunk.

After the panel is loose all around, slowly pull back the panel and unplug the rear bumper sensor.

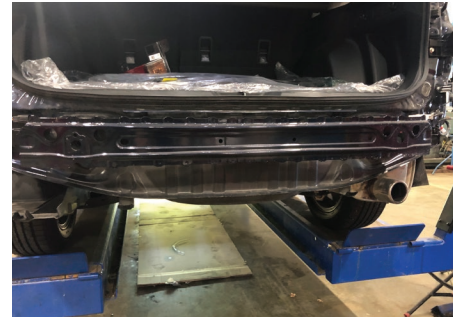

#### Step 5

Using a 14mm socket and socket extension, remove the nut and two bolts on each side of the bumper. Remove the bumper and insert the trailer hitch as shown.



#### Step 6

Secure the trailer hitch with the provided 7/16" conical tooth washer (#3), M10 flange nut (#2) and M10 hex bolts (#1).



### Step 7

Lower the muffler by removing the two rearmost rubber exhaust hangers.

**Note:** Be sure to support the exhaust to prevent damage during removal.

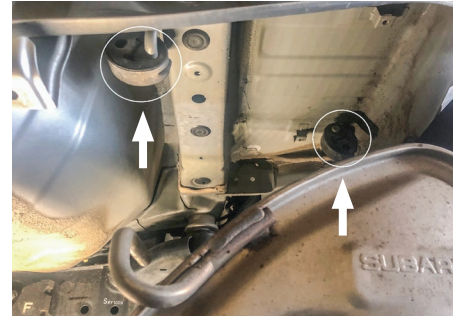

### Step 8

Using a 10mm socket, remove the four screws securing the heat shield. Remove heat shield and trim off the area marked 'M'.

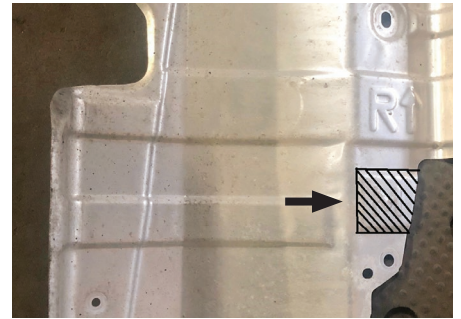

### Step 9

On both sides of the vehicle, fishwire (#8) a square hole washer (#6), and 1/2" carriage bolt (#4) through the square hole on the bumper to the plug hole.

Remove the fish wire and install a round hole washer (#5) and 1/2" flange nut (#7).

Using a torque wrench and 3/4" socket, tighten to 110 ft-lbs.

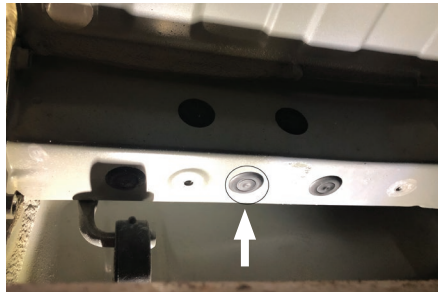



## Step 10

Using a 14mm socket, tighten the bumper nuts on each side of the vehicle to 33.4 lb-ft.

Tighten the bumper bolts to 47.8 lb-ft.



## Step 11

Cut a 3" x 8-1/2" and 2-1/2" x 1-1/2" opening in the center of the bumper fascia as shown.

Reinstall the heat shield, exhaust hangers, fascia and taillights.

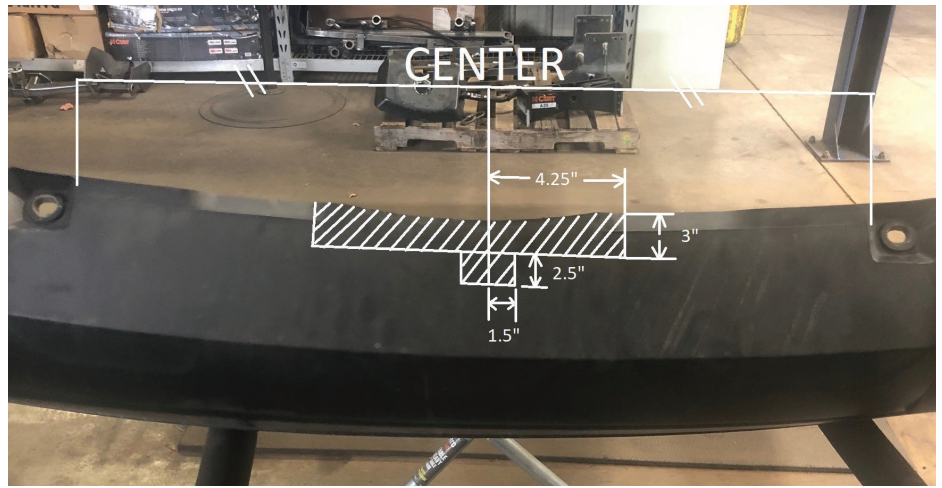

## Final Installed Image



## TOWING BASICS & SAFETY INFORMATION

For information on safely towing your trailer, visit [curtmfg.com/understanding-towing](https://www.curtmfg.com/understanding-towing).