

13651**FORD ESCAPE / MAZDA TRIBUTE / MERCURY MARINER**

1/28/2013

(VEHICLES WITH O.E.M. HITCHES)

GROSS LOAD CAPACITY WHEN USED AS A WEIGHT CARRYING HITCH: 3,500 LBS. TRAILER WEIGHT & 350 LBS. TONGUE WEIGHT.
 GROSS LOAD CAPACITY WHEN USED AS A WEIGHT DISTRIBUTION HITCH: 5,000 LBS. TRAILER WEIGHT & 500 LBS. TONGUE WEIGHT

*****DO NOT EXCEED VEHICLE MANUFACTURER'S RECOMMENDED TOWING CAPACITY.*****

Parts List			
ITEM	QTY	PART NUMBER	DESCRIPTION
1	2	1/2-13 x 1 3/4	CARRIAGE BOLT
2	2	CM-SP6	.250 x 1.00 x 3.00" SQUARE HOLE SPACER
3	2	1/2"	CONICAL TOOTHED WASHER
4	2	1/2-13	HEX NUT
5	2	CM-SP7	.250 x 1.00 x 2.00" SQUARE HOLE SPACER
6	4	9/16" CONICAL WASHER	CONICAL TOOTHED WASHER
7	4	M14-2 x 40mm LG.	HEX BOLT
8	2	1_2 FISHWIRE	1/2" FISHWIRE

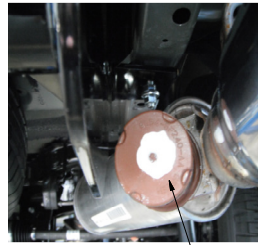

EXHAUST DAMPENER

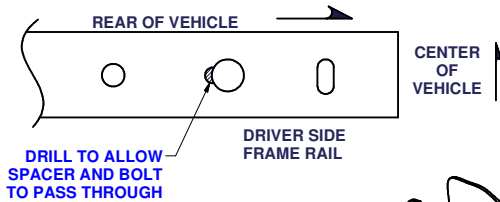

DRILL TO ALLOW SPACER AND BOLT TO PASS THROUGH

DRIVER SIDE FRAME RAIL

TIGHTEN THIS HARDWARE 1ST

TIGHTEN THIS HARDWARE 2ND

FRONT
↑
REAR

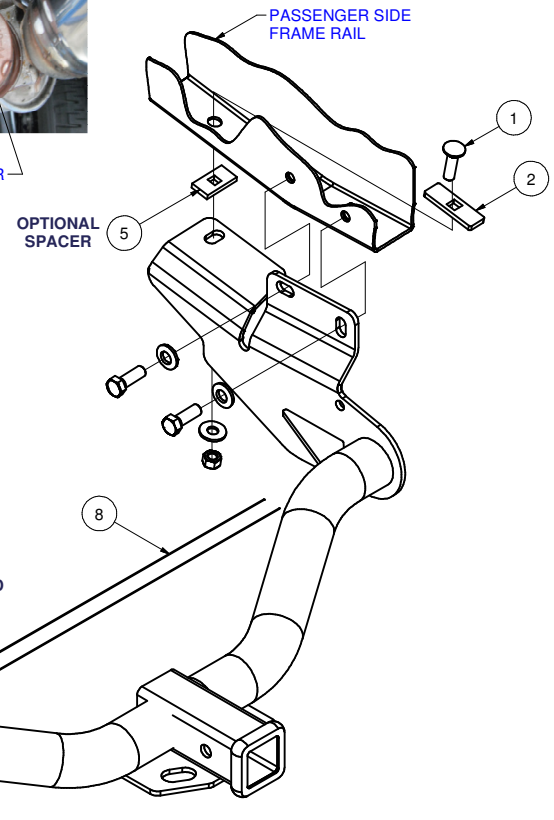

HITCH WEIGHT: 38 LBS.
 INSTALL TIME: 60 MINUTES
 INSTALL NOTES:
 - REQUIRES DRILLING
 - MAY REQUIRE EXHAUST BRACKET MODIFICATION

INSTALLATION STEPS

NOTES:

- If vehicle is equipped with an exhaust vibration dampener that interferes with the side plate, bend or pry the dampener away from the side plate as needed.
- 1) Remove four existing bolts from inside frame rails. Relocate existing electrical bracket by removing two screws and rotating the bracket 180°, repositioning connector to face toward the rear of the vehicle as before.
 - 2) Using the fishwire, pull the carriage bolts and spacers through the previously enlarged frame rail holes and into position.
 - 3) Raise hitch into position and install conical tooth washers and hex bolts into existing weldnuts. (Optional spacers can be assembled at this time). 1/2" hardware to be tightened 1st. M14 hardware 2nd.
 - 4) Torque all 1/2" hardware to 110 ft-lbs and all M14 hardware to 126 ft-lbs.

PERIODICALLY CHECK THIS RECEIVER HITCH TO ENSURE THAT ALL FASTENERS ARE TIGHT AND THAT ALL STRUCTURAL COMPONENTS ARE SOUND.

Curt Manufacturing Inc., warrants this product to be free of defects in material and/or workmanship at the time of retail purchase by the original purchaser. If the product is found to be defective, Curt Manufacturing Inc., may repair or replace the product, at their option, when the product is returned, prepaid, with proof of purchase. Alteration to, misuse of, or improper installation of this product voids the warranty. Curt Manufacturing Inc.'s liability is limited to repair or replacement of products found to be defective, and specifically excludes liability for incidental or consequential loss or damage.