

14041 1997-2004 F-150 & F-250 / F-250 & F-350 SUPER DUTY

6/13/2012

GROSS LOAD CAPACITY WHEN USED AS A WEIGHT CARRYING HITCH: 10,000 LBS. TRAILER WEIGHT & 1,000 LBS. TONGUE WEIGHT.
GROSS LOAD CAPACITY WHEN USED AS A WEIGHT DISTRIBUTION HITCH: 12,000 LBS. TRAILER WEIGHT & 1,200 LBS. TONGUE WEIGHT

***** DO NOT EXCEED VEHICLE MANUFACTURER'S RECOMMENDED TOWING CAPACITY.*****

HAVING INSTALLATION QUESTIONS? CALL TECHNICAL SUPPORT AT 1-800-798-0813

Parts List			
ITEM	QTY	PART NUMBER	DESCRIPTION
1	6	CM-SP1	.250 x 1.50 x 2.00" SQUARE HOLE SPACER
2	6	1/2 - 13	HEX FLANGE NUT
3	6	1/2-13 x 1 3/4	CARRIAGE BOLT

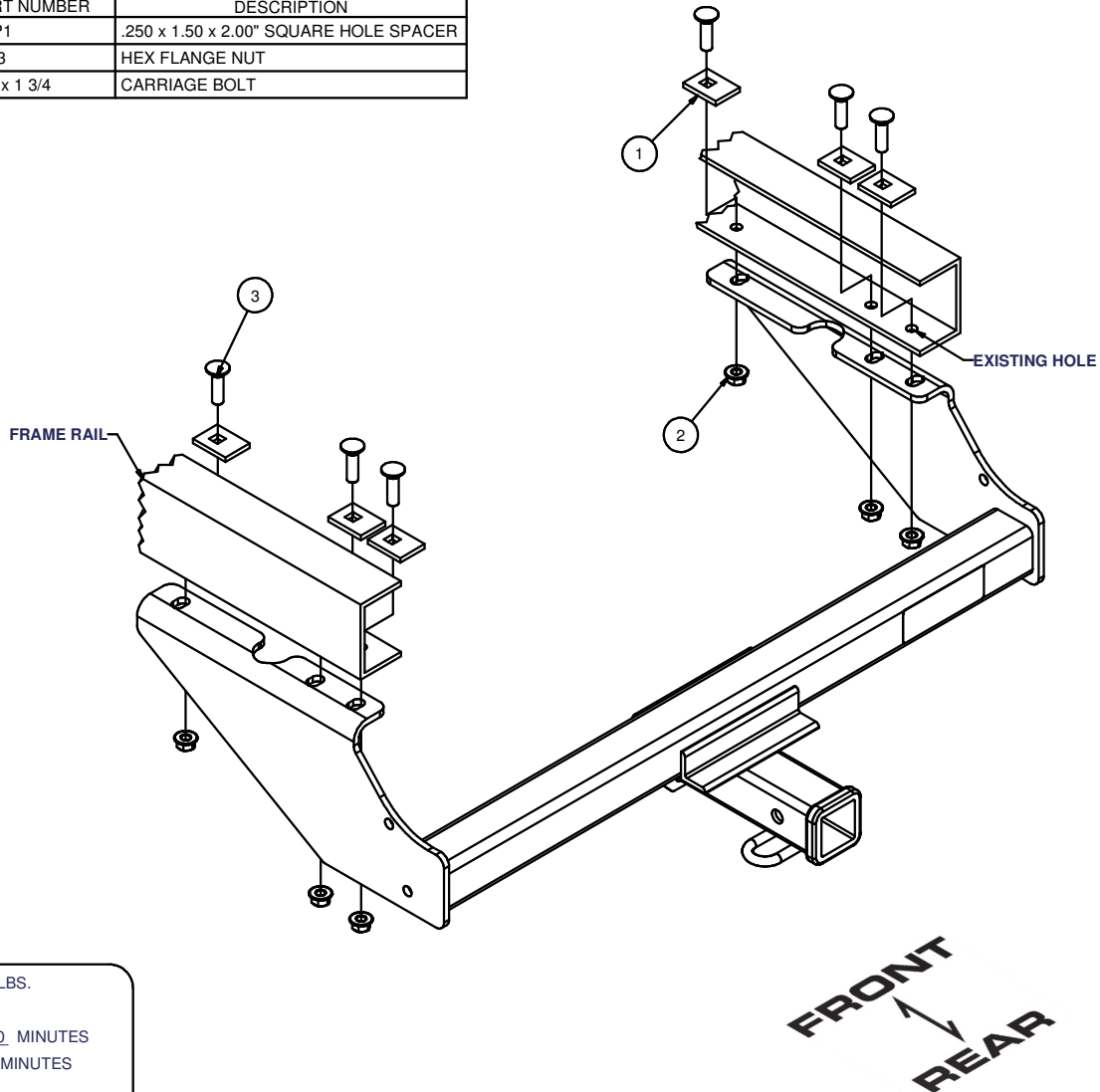

HITCH WEIGHT: 52 LBS.

INSTALL TIME

PROFESSIONAL: 30 MINUTES

NOVICE (DIY): 60 MINUTES

INSTALL NOTES:

- NO DRILLING REQUIRED

INSTALLATION STEPS

1. Lower the spare tire before beginning hitch installation. **Note:** Spare will be reinstalled after hitch installation.
2. Insert the 1/2-13 x 1 3/4" carriage bolts and the SP1 spacers through the holes in the frame rails.
3. Raise the hitch into position by aligning the carriage bolts with the holes in the hitch and secure with 1/2" flange nuts.
4. Torque all hardware to 110 ft-lbs.
5. Reinstall the spare tire. **Note:** After the hitch is installed you may need to push the spare tire toward the front of the truck to provide clearance between the tire and the hitch.

PERIODICALLY CHECK THIS RECEIVER HITCH TO ENSURE THAT ALL FASTENERS ARE TIGHT AND THAT ALL STRUCTURAL COMPONENTS ARE SOUND.

Curt Manufacturing Inc., warrants this product to be free of defects in material and/or workmanship at the time of retail purchase by the original purchaser. If the product is found to be defective, Curt Manufacturing Inc., may repair or replace the product, at their option, when the product is returned, prepaid, with proof of purchase. Alteration to, misuse of, or improper installation of this product voids the warranty. Curt Manufacturing Inc.'s liability is limited to repair or replacement of products found to be defective, and specifically excludes liability for incidental or consequential loss or damage.