



INSTALLATION INSTRUCTIONS
2005-up Ford Mustang 10-POINT ROLL CAGE
C3240

Please read the instructions completely BEFORE starting this project.

Competition Engineering 10-Point Roll Cages are **not** designed for use in vehicles where the stock floor has been removed. Check your sanctioning body's rulebook for installation guidelines.

To help you install this 10-Point Roll Cage; we've provided you with this step-by-step instruction manual. These directions are a general guideline for a typical roll cage installation and are not written specifically for your application. If you have installed a roll cage before, this will be a quick refresher course.

The installation process will involve fitting the bar components into the racecar, notching the tube ends, trimming the bars to fit and then tack welding the tubing together before making the final welds. By following this procedure, any minor mistakes can be corrected easily and with the smallest loss of valuable time.

NOTE: THE MATERIAL FURNISHED IS NOT TO BE CONSIDERED A COMPLETELY FINISHED AND FITTED ASSEMBLY. INSTALLED DIMENSIONS ARE NOT PROVIDED WITH THESE INSTRUCTIONS. THE ROLL CAGE IS TO BE INSTALLED TO YOUR OWN PERSONAL SATISFACTION WITHIN SANCTIONING BODY RULES AND THE GUIDELINES SET BY COMPETITION ENGINEERING IN THESE INSTRUCTIONS.

This Roll Bar has been designed specifically for the 2005-up Mustang application. Some of the tubes will require notches, and some minor trimming to meet your specific needs. Refinement of the notches should be done as carefully as possible. We recommend using a hand grinder or if possible a hole saw type tube notcher to prepare the ends of the tube for proper fit. The notches should allow for a slight gap to help maximize weld penetration. Also make sure to dress the notched end of the tube with a grinder or hand file to remove burrs and provide a chamfer for improved weld appearance.

We recommend that all welds be done with the approved MIG or TIG welding process. A machine with 130-amps or higher should be used. **DO NOT USE FLUX CORE WIRE TO WELD THIS ROLL BAR.**

If you are unsure about your welding abilities, have a professional welder complete the installation. Follow all safety guidelines that are provided with the equipment you are using. Always wear eye protection.

*For Technical Assistance, call Competition Engineering's Tech Line at
(203) 458-0542, 8:30am-5:00pm Eastern Time*

COMPETITION ENGINEERING
80 Carter Drive • P.O. Box 1470 • Guilford CT 06437
Phone: (203) 453-6571 • Fax: (203) 458-3581

TABLE OF CONTENTS

- I. Material parts list with identifying names
- II. List of tools required
- III. Step-by-step instructions
- IV. Illustrations for reference

I. PARTS LIST

- | | |
|--------------------------------|-----------------------|
| 1) Main Hoop | 1) Top Eyebrow Hoop |
| 2) Rear Struts | 2) Door Struts |
| 1) Main Harness Crossbrace | 2) Forward Downstruts |
| 12) Gussets | 2) 6"x6" Plates |
| 2) Main Hoop Plates | 2) Rear Strut Plates |
| 2) Main Hoop Supports 39" Long | |

II. TOOL LIST

- Power Band Saw or Hand hacksaw to shorten tubing
- Body Grinder with coarse wheel to remove paint and rust. Also to refine tube notches.
- MIG or TIG Welder with 130 amp minimum rating
- Protective Face Shield for grinding and welding
- Sheetmetal Shears to modify or remove interior panels.
- Die Grinder or Electric Drill with rotary file to notch tube ends.
- Tape Measure, Hammer, C-Clamps, Locking Pliers, Magic Marker
- 4 Jack Stands to support vehicle
- Carpenter's Level and Angle Finder
- Bench Vise to hold tubing while grinding and cutting.

For a professional looking installation we highly recommend the following materials and tools:

- .030"-.035" Mild steel welding wire
- Thin cardboard to cover the windows. This protects the glass from welding and grinder sparks.
- 80-Grit sandpaper to remove paint and light surface rust
- Holesaw type tube notcher
- Scrap pieces of sheetmetal to protect the headliner during welding.

III. INSTALLATION

1. Always disconnect both battery cables before welding
2. Always check for fuel lines under the vehicle before welding; remove or isolate as necessary
3. Begin the installation process by removing the interior from the vehicle. This includes both front and rear seats, carpet and sound deadening.
4. Install the protective cardboard over all exposed interior glass. Don't forget to cover-up your gauges and radio if they are installed. Grinder and welding sparks go everywhere.
5. Jack-up the vehicle and support it in four places with approved jack stands. You want to take extra time to make sure the vehicle is level from front to back and side to side. Steel shims can be used between the jackstands and the chassis to achieve proper level.
NOTE: Do not let the chassis droop on the jackstands. If this is allowed to happen during the roll cage installation this droop will become permanent.
6. We are now going to trial fit the main hoop. Take a measurement from the headliner to the mounting point for the base of the main hoop. Turn the main hoop upside down on the shop floor and measure from the floor to the end of the hoop leg. Mark the hoop legs at the dimension you measured in the car. Cut the tubes at this mark. (For the 2005-up Mustang- the main hoop for the cage can pass thru the factory drain holes and floor plate to mate up with Competition Engineering # C3142 frame connectors. To do so remove the factory drain plugs from the floor pans. Clean any attaching area for welding. Our frame connector will be the main attaching point of the main hoop in conjunction with the floor plates. If not using Competition Engineering frame connectors, the main hoop must be welded to the included floor plates.)
7. With the driver's seat installed and the driver seated with helmet on, determine the position of the main hoop.
NOTE: It is recommended that the main hoop be no further than 6" from the back of the driver's helmet (check your sanctioning bodies rulebook).
Trial fit the main hoop in the car. Try to align the vertical positions of the main hoop with the door pillar. Make sure it is centered in the vehicle by measuring from the door jam to the edge of the hoop on each side. If it fits snug, mark the leg positions on the floor with a marker. Remove the hoop from the car. (If using connectors measure from the topside of the connector tube to headliner and follow previous instructions. Angle the main hoop to match door line.)
8. Place the main hoop flat on the floor and stand the top hoop on the main hoop so that the open ends of the tubes make contact just below the "A" bends. Check the fit. Modify the ends to achieve a good weld joint.
9. Grind the area marked in Step 5 so that you can install the supplied steel floor plates.
10. Position two of the plates on the floor under the area of the main hoop legs. Tack weld them in place. (remove or completely isolate fuel lines under floor)
11. Re-install the main hoop in the car and tack weld it to the previously installed plates. Re-check the position of the main hoop. (If using Competition Engineering frame connectors drop hoop through drain holes and tack weld main hoop to the frame connector joints as well as the floor plate. remove or completely isolate fuel lines under floor)

12. We are now going to install the rear struts. The rear struts connect the main hoop with the rear frame at the upper spring mounts. They should be installed parallel to each other and directly over the rear frame rails.
- Drop a plumb bob down from the top of the main hoop even with the outside of the rear frame rails and mark the position on the hoop. This is the outside mounting point for the rear struts.
 - Take a measurement from the mark on the main hoop to the desired end point for the rear struts.
 - Cut the struts to this dimension. Remember to take into account the angle needed, if any, on the end of the tube.
 - For rear trunk plate mounting points. Place mounting plate over attaching point, now mark and prep the area for welding (remove seam sealer/paint.) The plates are to be located as far back to the tail panel as possible. The hole in the plate should line up with the factory stud sticking up. Using a cut off wheel remove existing stud or trim it back to allow stud to pass thru mounting plate and allow sufficient height to weld to. Now tack and weld completely around the trunk plate, be sure when welding to keep the heat from welding within the mounting plate and not to the cars thinner sheet metal, this may structurally weaken your welding points. Tack weld the rear struts in place.
13. With the driver seated, measure for the height of the main hoop harness bar. This is the tube that mounts between the legs of the main hoop and supports the driver's seat in the event of impact. It also acts as a structural member for the shoulder harness. Follow your sanctioning body's guideline for correct placement.
- Cut the un-notched end of the tube to the correct dimension taking into account the notch that needs to be added to the end of the tube (typically 5/8" extra).
 - Fit the crossbrace and tack in place if the fit is correct. Make sure that the tube is level.
14. We will now install the top hoop. The top hoop should be installed so that the front is level and pushed as high into the roof as possible. It should not limit the driver's vision.
- Take a measurement from the main hoop to where the front of the top hoop should be. If necessary, shorten the top hoop to meet this dimension and re-notch.
 - Fit the hoop in the car, and then mark its location on the main hoop.
 - Check the positioning of the top hoop and tack weld in place.
- NOTE: If you are working alone; there are several methods of holding the top hoop in place for tack welding. One method is to tie a rope around the hoop and hang it from the roof of the car. Or, if you have access to a ratcheting tie-down, you can support the front of the hoop with a piece of 2"x4" cut to proper length with a V-notch in one end and loop the tie-down around the top of main hoop and the front of the top hoop. Tighten the tie-down so that it draws the top hoop towards the main hoop.
15. Now measure and install the two forward downstruts. These tubes support the front of the top hoop and are designed to mount in front of the dashboard. Their position has a direct relationship on the driver's visibility so space them as far apart as possible and as close to the windshield posts as possible. (See strut diagram for ideal trimmed length).
- Determine the location of the tubes and where they will meet the floor. Clean this area on the floor and tack weld another set of 6" x 6" plates.
 - Fit the downstrut tubes to determine how much, if any, needs to be trimmed from the end of the tube. Make sure that the notch fits properly and that you can weld the joint completely.
 - Tack weld the tubes in place. (Remove or completely isolate fuel lines under floor).

16. The next part of the installation is the main hoop supports. These tubes span from the intersection of the main hoop and main hoop crossbrace to the top of the subframe connector or rear frame rail near the front ladder bar or 4-link brackets. These supports will improve chassis reaction time and make the car less flexible.
- Determine the route for the tube. Make a template of the notch required on the ends of the tube using a piece of paper wrapped around the end of the tube. Slide the paper up into the location for the notch and mark the contours on the paper. Trim the paper as if it were the piece of tube being notched. Refine the cut in the paper until you have a perfect fit. Transfer this shape to the end of the main hoop supports.
 - Trial fit the tube to the car. Tack weld in place.
17. The last part of the roll cage to be installed is the door bars. The door bar spans from the main hoop to the intersection of the front downstruts and the floor plate. Most sanctioning bodies require that the door bar passes by the driver at a point between the shoulder and the elbow. The driver should be seated in the car to properly locate the door bars. Follow your sanctioning body's guideline for correct placement.
- The front of the door bar is to be located at the bottom of the front downstrut where it meets the floor plate. Notch and fit the front of the door bar so that it gets welded to both the floor plate and the front downstrut.
 - Notch the back of the door bar to fit against the main hoop. Work slowly and carefully here, mistakes happen easily on this type of notch.
 - When you are satisfied with the fit, tack weld the bar in place (remove or completely isolate fuel lines under floor).

Tip: Door bars - Trim the door bars to lie on the floor plate and mate with forward strut. Make sure there is sufficient clearance between the door panel and door bars with the doors closed, otherwise contact with the door panel may occur. Fit up door bar to floor plate and main hoop, mark the favored position.

18. With all the roll cage tubes tack welded in place, proceed to check each union to ensure that no tack welds have broken. Secondary tack welds are placed at every union and at areas where previous tack welds have been completed. You can obtain the best results by following this procedure. Begin by placing additional tack welds opposite existing tack welds. You will need between two and three tacks around each tube to prevent the cage from drawing. Secondary tacks should also be placed in areas that will be difficult to reach during finish welding. Other areas for secondary tack welds will include tubes that don't fit tightly or are in areas where the tubes form a deep angle.
19. Finally, we come to the last major step: finish welding all frame substructures and floor plates. This should be done from side to side and top to bottom of each union, starting from the inboard and working your way outward to the rocker sill area. Be sure each connection is free from grease, oil or dirt; this will make the end result much better visually and structurally. Finish weld the entire roll cage in the same order you installed each component part. Work on the center section first, then move on to the rear and then the front sections, using the same side to side, top to bottom welding method. If you are not able to weld completely around a joint, a gusset must be used on both sides of the incomplete weld. If any porosity is encountered during welding, grind it out and re-weld. Be sure to check each joint for complete welds around the circumference of the tube joint. With the welding completed, the roll cage can be degreased, sanded and painted.

Tip: To fit stock rear package tray back into car: Trace the holes cut into metal rear deck frame, for the rear struts, onto the package tray itself. You can use Competition Engineering Firewall / Tray kit part# C4990, aluminum kit to meet sanction body requirements.

Now install the rear struts and tack them in place. Now continue with the previous steps to complete installation.

Tip: The main hoop can be dropped thru the drain holes in order to tack and weld the rear struts to the main hoop before the front struts and door bars are tacked in place.

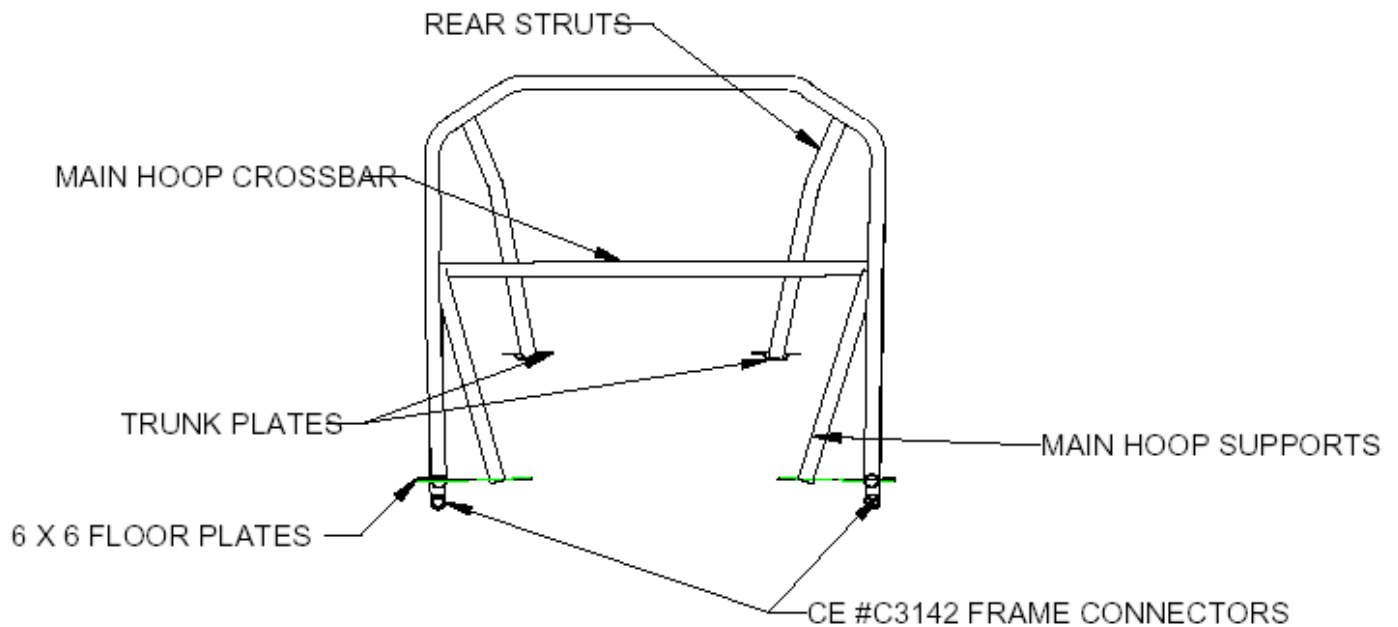
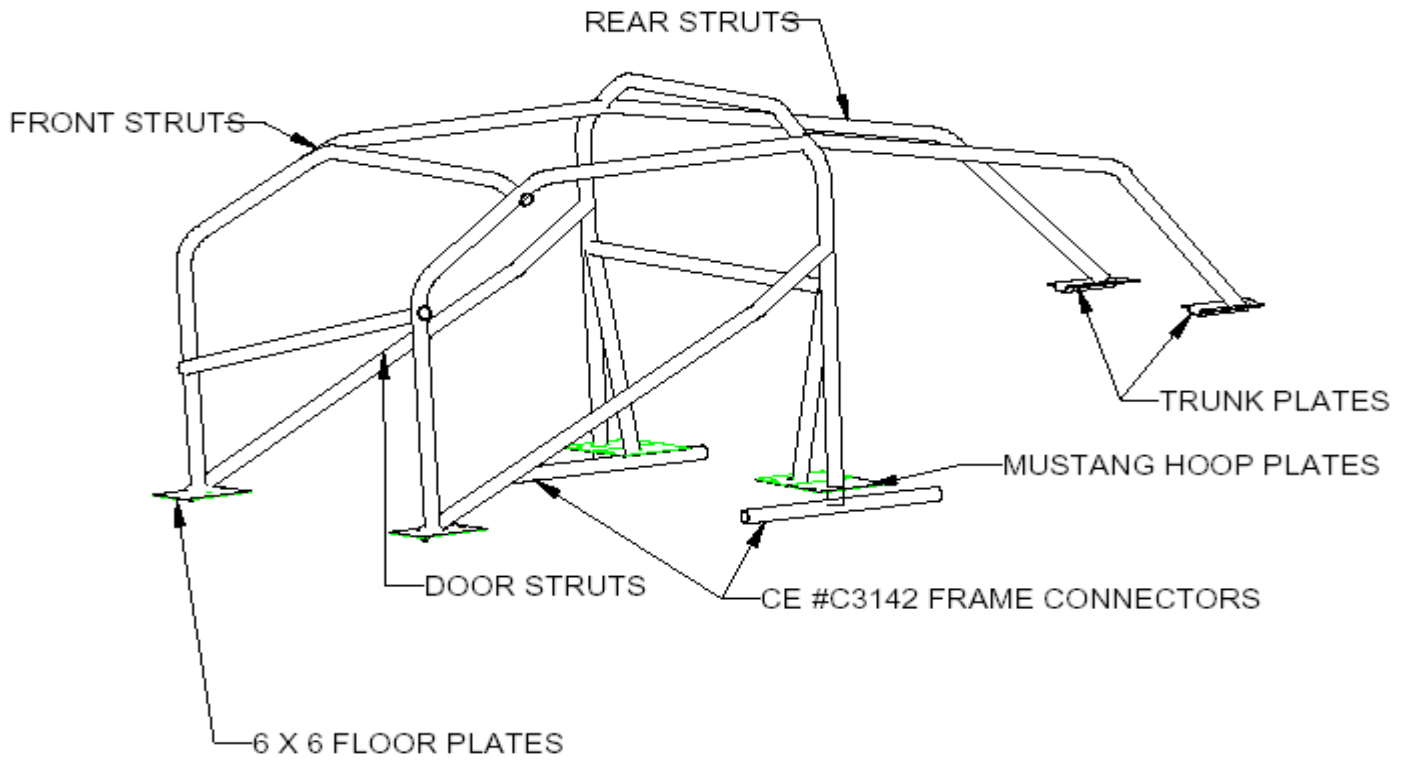

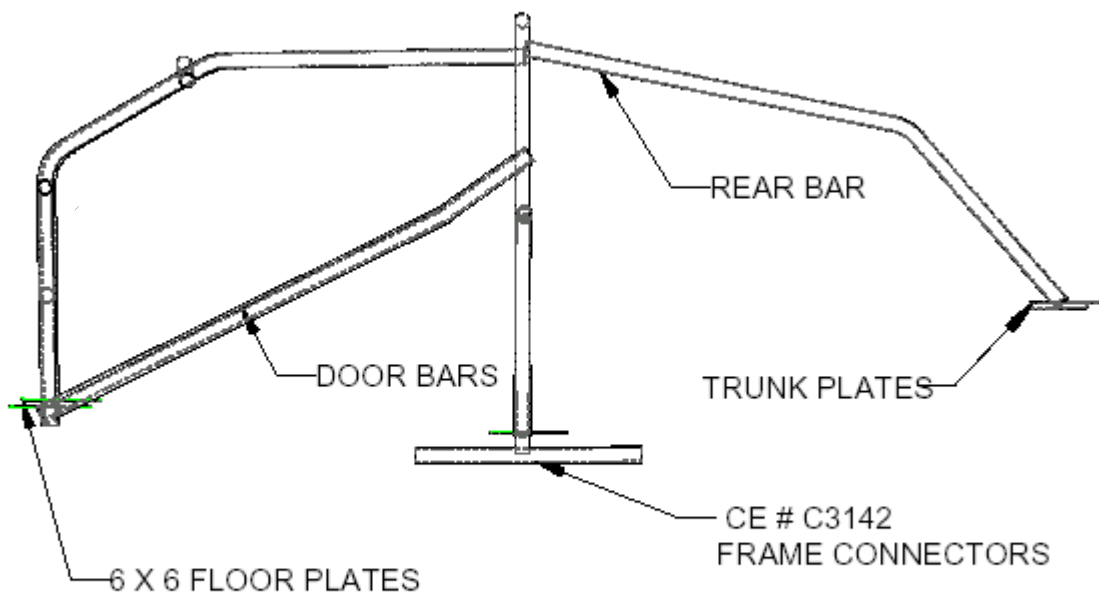
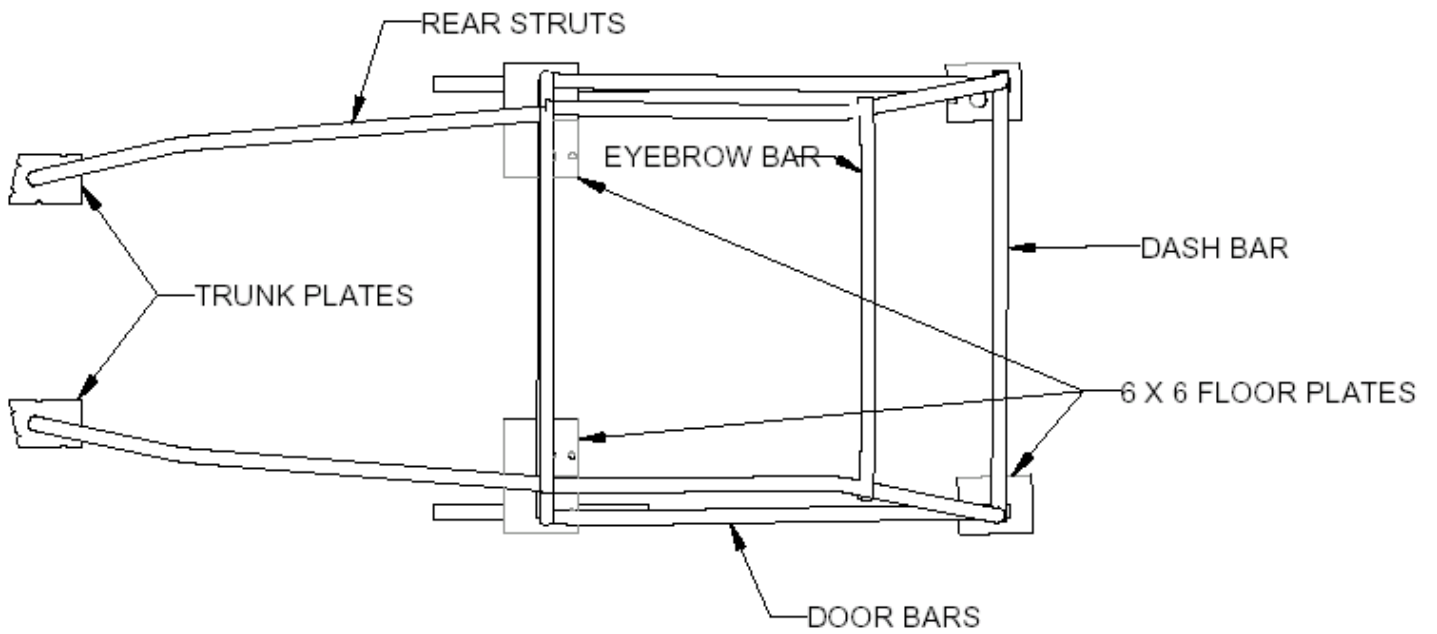

STRUT DIAGRAM

