

**2021+ Chevy Tahoe & Suburban
5.3L/L84 Side Exit**



**IMPORTANT!
WARRANTY AND INSTALLATION
INSTRUCTIONS**

Please Forward All Information to End Consumer

Be sure to review the enclosed instructions prior to beginning the installation process. If you have any questions about the enclosed parts or instructions, or if you encounter a problem during installation:

CALL TECHNICAL SUPPORT: 440.891.0999 or 800.486.0999

**TO ACTIVATE YOUR WARRANTY, GO TO:
corsaperformance.com/warranty**

**COLOR INSTRUCTIONS ARE AVAILABLE BY PART NUMBER ON:
corsaperformance.com**



NEVER work on a hot exhaust system.
Allow time for the vehicle to cool.

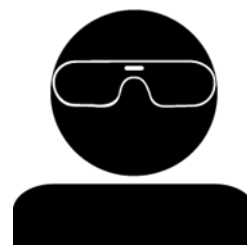

**Always wear eye protection
when working under a vehicle.**

INSTALL DIFFICULTY



Recommended Tools & Supplies

- 11mm Socket & Ratchet or Wrench
- 13mm Socket & Ratchet or Wrench
- 15mm Socket & Ratchet or Wrench
- Grommet Pulling Pliers or Similar
- Torque Wrench
- Small Flat Head Screwdriver

Please take time to read and understand these installation instructions.

CORSA recommends that the installation of this system be performed by a qualified service center or professional installer who has the necessary equipment, tools, and experienced personnel. However, if you decide to perform this installation yourself, the use of an additional person may be required.

WARNING: Never work on a hot exhaust system. Allow time for the vehicle to cool.
Always wear eye protection when working under a vehicle.

This warranty does not extend to damaged or defect in the finish of a product or to any product, that in the opinion of CORSA Performance, has been misused, damaged by accident or negligence, altered, or modified in any way, faulty installation or installed contrary to CORSA installation instructions, or repaired by an unauthorized service facility. Full warranty available on www.corsaperformance.com

Please confirm that all parts are present according to the bill of materials before beginning the installation.

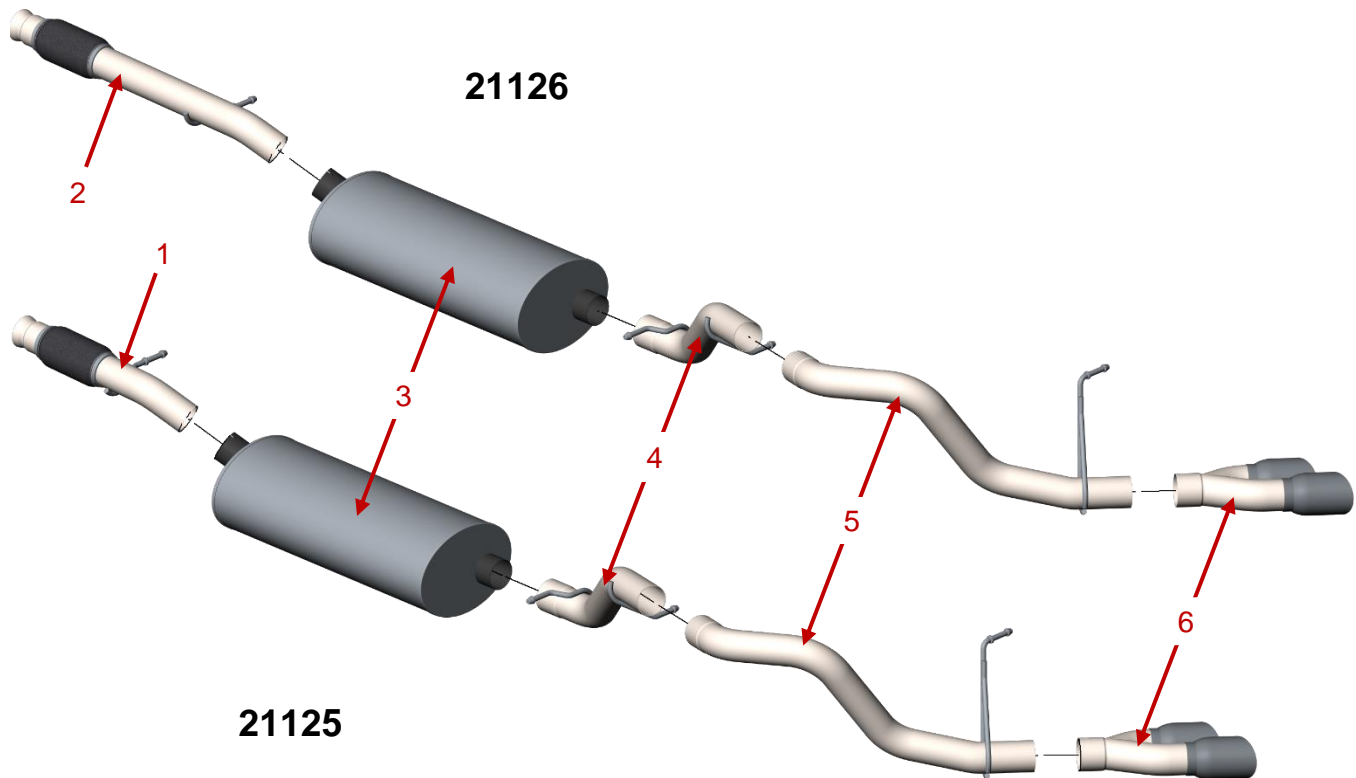

Bill of Materials

1. Short Wheelbase Head Pipe (16YD4113)	2. Long Wheelbase Head Pipe (16YD4117)
3. Muffler (16YD2014)	4. Mid-Pipe (16YD4115)
5. Tail Pipe (16YD4119)	6. Tip Assembly (14001)
7. Hardware Kit (16YD7054) (Not Shown)	8. Instructions (INS5422) (This Document)

If something is missing, call CORSA Tech Support at 440.891.099 or Toll Free: 1.800.486.0999

Removal Instructions

Factory Exhaust



1. Use a 13mm Socket & Ratchet or Wrench to remove the 4 Bolts that attach the Anti-Sway Bar to the Frame. Keep the Bolts in a safe place. They will be reinstalled on Installation Step 8.

After the Bolts are removed, rotate the Anti-Sway Bar down so it is out of the way.



2. Use a 13mm Socket & Ratchet or Wrench to remove the 2 Nuts from Flange Connection between the Factory Front Section and the Factory Tail Pipes.

This connection is above the Rear Axle.



3. Using Grommet Pulling Pliers or similar, remove the Tail Pipe Exhaust Hanger from the Grommet.

The use of a soap and water solution will aid in the removal of the hangers from the Factory Grommets.

After the Hanger is out of the Grommet, the Factory Tail Pipe can be removed by pulling it rearward and out behind the Passenger Rear Fender Well.

Continued on Next Page...

Removal Instructions

Factory Exhaust

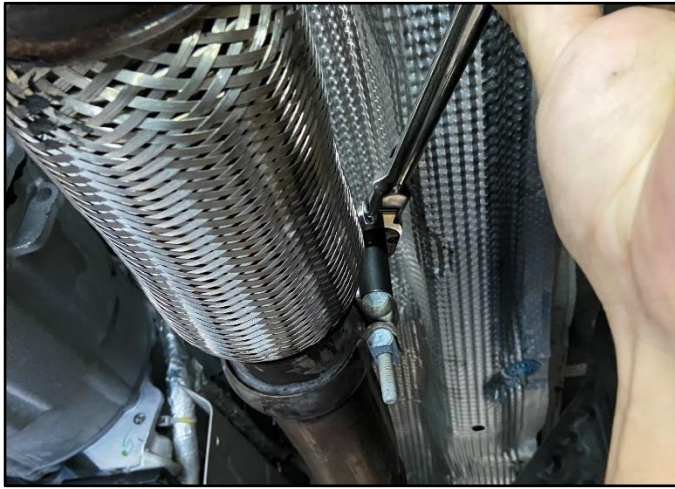

4. Using a 13mm Socket & Ratchet or Wrench, loosen the Spherical Clamp on Head Pipe. The clamp is attached to the Factory Head Pipe and will be removed in Installation Step 1.

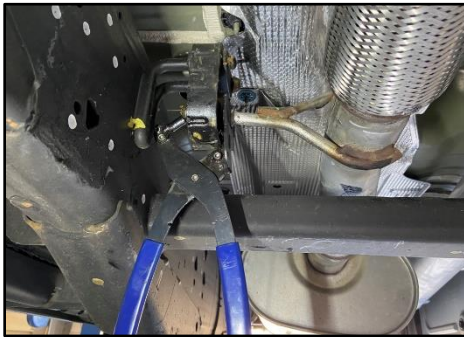

Head Pipe



Front Mid-Pipe

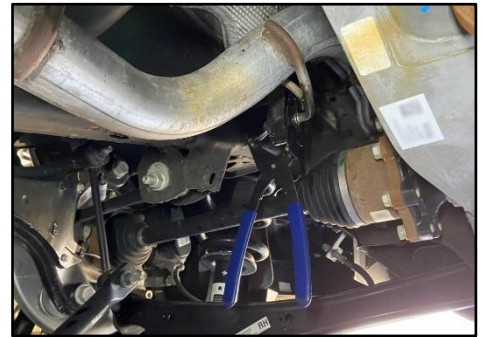

Rear Mid-Pipe

5. Using Grommet Pulling Pliers or similar, remove the Head Pipe Exhaust Hanger, the Front Mid-Pipe Exhaust Hanger, and the Rear Mid-Pipe Exhaust Hanger from the respective Grommets. Rest the Factory Mid-Pipe Flange on the vehicle's Rear Crossmember.
6. Next, pull back on the Factory Exhaust to release the connection at the Head Pipe until the Inlet and Flex Coupler can be pulled under the Crossmember. Then, bring the Factory Exhaust forward, under the Front Crossmember, and out from under the Vehicle. A second person may be needed to assist with this step.

This concludes the removal of the factory exhaust.

WARNING!!

DO NOT SKIP THIS STEP

WARNING!!

Apply the supplied Anti-Seize Lubricant to **ONLY** the threads of the clamps and flange bolts. Failure to follow this procedure can cause nuts to seize on clamps and potentially destroy the threads.

After applying anti-seize lubricant, be sure to thoroughly clean your hands. The Anti-Seize lubricant will tarnish stainless steel.

All clamps should be tightened using a properly calibrated Torque Wrench. Using an impact gun will damage the clamp and reduce its ability to effectively seal the joint. It may also cause the joint to separate, thereby causing damage to your exhaust system and to your vehicle.

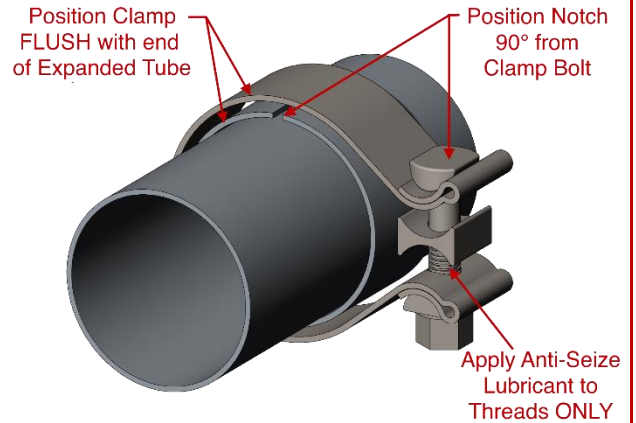

PRO TIP

Before installing, make a line 1 3/4 in on 3 in from the end of non-expanded side of the pipes and muffler. This is CORSA's nominal 3 in joint overlap. This will help during final adjustment. Do not be alarmed if the overlap varies slightly when the installation is complete. Any differences are caused by manufacturing variances from vehicle to vehicle and exhaust to exhaust.

Install Instruction

CORSA Exhaust



1. Locate the Factory Exhaust, using a small Flat Head Screwdriver, pry the Locking Tab up to release the Spherical Clamp from the Factory Head Pipe. Install the Spherical Clamp onto the CORSA Head Pipe.

Continued on Next Page...

Install Instruction

CORSA Exhaust

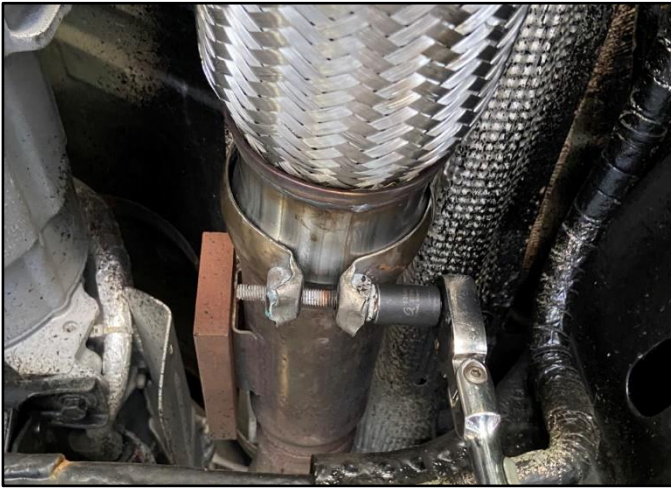

2. Slide the CORSA Head Pipe with previously installed Factory Spherical Clamp over the Connection on the Factory Exhaust Pipe. Press the Head Pipe Exhaust Hanger into the Grommet. Then, **SNUG** the Clamp with a 13mm Socket & Ratchet or Wrench.

DO NOT FULLY TIGHTEN at this time!



3. Install the CORSA Mid-Pipe by pushing the Front and Rear Mid-Pipe Exhaust Hangers into the corresponding Grommets. Note that the Inlet of the CORSA Mid-Pipe is the Expanded side.

Next, slide Exhaust Clamps over the Inlet and Outlet of the Mid-Pipe, and over the outlet of the Head Pipe



4. Lift the CORSA Muffler into position and slide the expanded inlet over the Head Pipe outlet. Then, while pushing the CORSA Mid-Pipe back, rotate the CORSA Muffler up. Slide the expanded Inlet of the Mid-Pipe over the outlet of the Muffler.

Confirm the joint overlaps and clearances to the vehicle, then **SNUG** the Clamps each side of the Muffler with a 15mm Socket & Ratchet or Wrench.

DO NOT FULLY TIGHTEN at this time!

Continued on Next Page...

Install Instruction

CORSA Exhaust

5. Install the CORSA Side Exit Pipe by positioning it above the vehicle's Rear Crossmember and over the Outlet of the CORSA Mid-Pipe. The Tail Pipe should have an approximate $\frac{3}{4}$ in vertical clearance to the Rear Crossmember. Adjust the clearance by rotating the Tail Pipe Inlet on the Mid-Pipe Outlet.

Once the clearance is correct, **SNUG** the Clamp with a 15mm Socket & Ratchet or Wrench.

DO NOT FULLY TIGHTEN at this time!

6. Starting at the Head Pipe, verify the all Hangers are properly in the Grommets, the Muffler is close to level, all connections are straight and there is proper clearance around the entire CORSA Exhaust and the Vehicle. Then starting at the Front Clamp, use a Torque Wrench to tighten the clamps to 45ft-lbs and the Factory Hanger Bolts to Factory specifications.

A second person may be needed to hold the components in the correct position while the clamps are being torqued.

7. Install the Side Exit Tip assembly by first sliding a 3in Exhaust Clamp over the outlet of the Side Exit Tail Pipe. Then push the Inlet of the Tip assembly over the Outlet of the Side Exit Tail Pipe. Align the Tip assembly so the Tips are parrallel with the body lines. There should be approxiamtly $\frac{3}{4}$ in between the top of the both Tips and the Vehicle Body. You may need to loosen the Tail Pipe Clamp for proper alignment.

Once everything is adjusted, retorque any loosen Clamps and Tip Assembly to 45ft-lbs. A second person may be needed to hold the Tip Assembly in the correct position while the clamps are being torqued.

8. Rotate the Anti-Sway Bar up into position and reinstall the 4 Bolts that attach to the Frame. Use a 13mm Socket & Ratchet or Wrench and tighten the bolts to the factory recommended torque value.

This concludes the installation of the CORSA Exhaust.

Before Road Testing

1. Start engine, leaving the transmission in park and/or securing the parking brake.
2. Make sure to look and listen for any unusual noises. Repair problems if needed.
3. Immediately following the installation of your exhaust system, you may experience a trace of smoke after initial start-up. Do not be alarmed. The smoke is caused by the burning of a small amount of forming oil residue used in the manufacturing process.
4. It is strongly suggested that the alignment of the components be checked and all clamps re-torqued after road testing the vehicle and allowing the system has fully cooled.
5. During cold weather start-ups, you may experience an exhaust sound that is deeper and louder in tone than usual. This is temporary and will diminish to normal levels once your engine has reached its normal operating temperature.