

Please take time to read and understand these installation instructions.

dB Performance Exhaust recommends that installation of this system be performed by a qualified service center or professional muffler installer who has the necessary equipment, tools and experienced personnel. However, if you decide to perform this installation, the use of a hoist or lift and an additional person will be required.

CAUTION: Never work on a hot exhaust system. Allow time for the vehicle to cool. Always wear eye protection when working under a vehicle.

Please confirm that all parts are present before beginning the factory exhaust system removal and dB Performance exhaust system installation.

Bill of Materials:

- 1 – dB 4" Slash Cut Tip (16SE3023)
- 2 – Sport Muffler (25TU2003)
- 3 – Front Tailpipe Assembly (25TU4046)
- 4 – Rear Tailpipe Assembly (25TU4049)
- 5 – Head Pipe Assembly (25TU4052)
- 6 – Hardware Kit (25TU7024)

Recommended Tools:

- Safety Glasses
- 12mm Socket
- 13mm Socket
- 14mm Socket
- 9/16" Socket
- 3/8" Ratchet
- Grommet Pullers
- Soap & Water Solution
- Torque Wrench

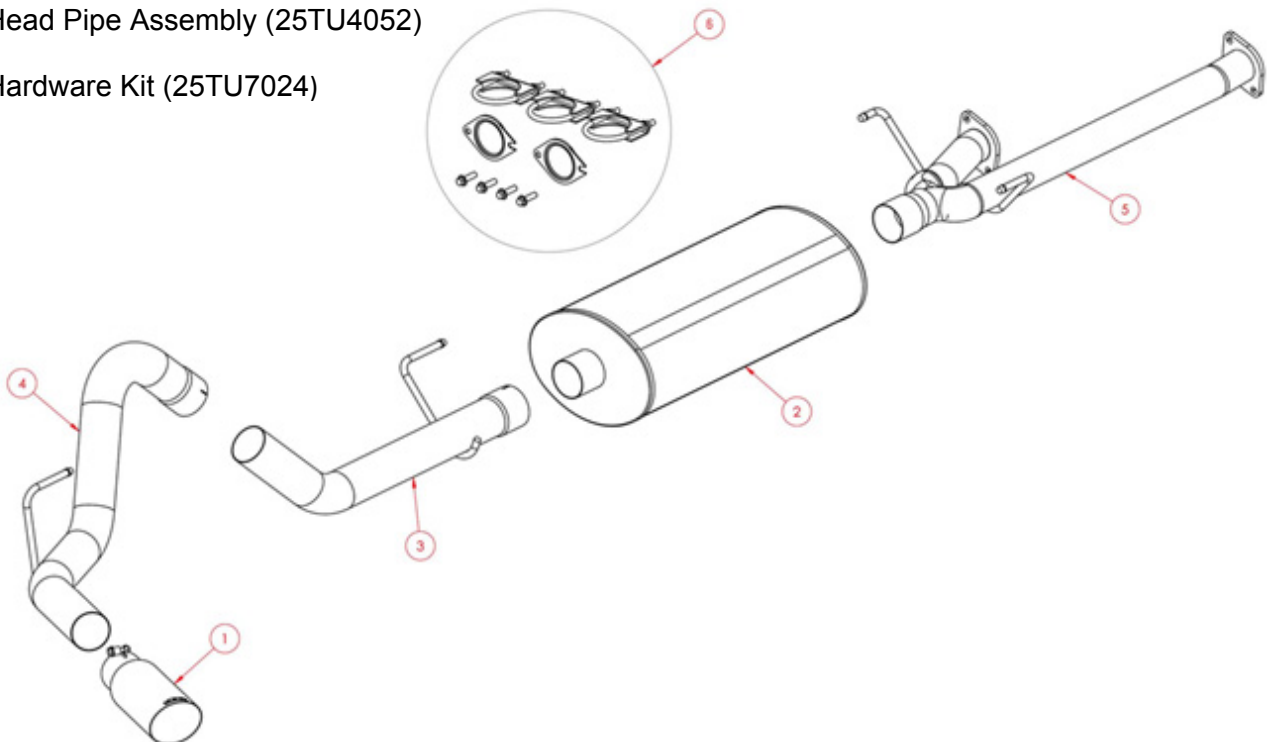

REMOVAL OF STOCK EXHAUST:

1. Remove the V-band clamp bolt and clamp located just behind the muffler outlet using a 12mm socket. You do not need to reuse the V-band clamp. **(See Fig. A)**
2. Remove the tailpipe hangers from the rubber grommets using grommet pullers or similar device. Then remove the tailpipe by lifting it up off of the muffler outlet pipe and sliding it back and over the rear axle. **(See Figs. B & C)**

NOTE: Using a soapy water solution on all grommet holes will make the job easier.

3. Remove the driver and passenger front pipes and muffler by removing the (4) flange bolts after the catalytic converters using a 14mm socket. **(See Fig. D)**
4. Remove the muffler hangers from the rubber grommets using grommet pullers or similar device and remove the front pipes and muffler assembly. This completes the removal of the stock system. **(See Figs. E, F & G)**



FIG. A

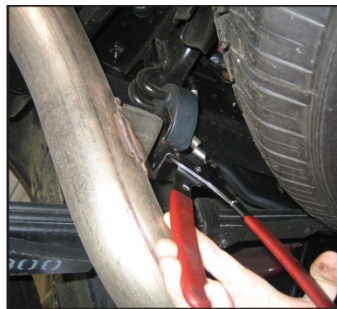

FIG. B



FIG. C

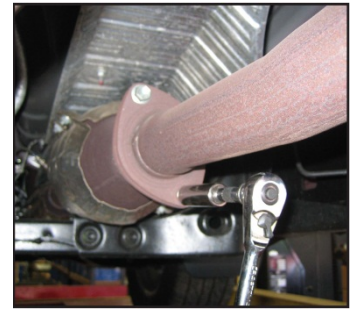

FIG. D.



FIG. E



FIG. F



FIG. G

If at any time you need technical assistance, call (800) 486-0999 to speak with a representative or visit www.dbexhaust.com

Installation of Exhaust System:

NOTE: The supplied double edge clamps in this system will crush and permanently deform the exhaust piping as they are tightened. **DO NOT** tighten these clamps any more than is necessary to lightly hold the exhaust components in place, until the very end of this installation process. It will be difficult or impossible to make any positional or rotational adjustments to the exhaust system after these clamps have been tightened down.

VERY IMPORTANT: Align all clamps so that the open edge of the clamp bracket is parallel and aligned with the notch in the pipe, and the outside edge of the clamp bracket is approximately 1/8" from the end of the pipe expansion. (See Fig. H) Failure to properly position or orient the clamps could result in a weak clamping load, or even a potential leak at the clamp joints.

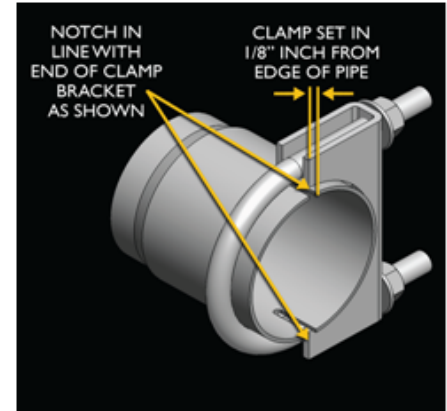

Fig. H

1. Remove all exhaust system components from the shipping carton, including the three supplied clamps, both flange gaskets, and the four M10 flange bolts.

NOTE: Using a soapy water solution on the hanger grommets at this time will make the following steps much easier to accomplish.

2. Locate the dB Performance head-pipe assembly, along with the four supplied M10 flange bolts and the two supplied flange gaskets. Replace both of the flange gaskets, then place both of the head-pipe hangers into the factory rubber grommets. Align the head pipe flanges to the factory flanges, and then snug tighten the two bolts at each flange location using a 14mm socket and ratchet. **(See Figs. I, J & K)**
3. Locate the dB Performance muffler, and one of the supplied clamps. Slide the expanded end of the muffler inlet pipe onto the outlet of the head-pipe assembly. **(See Fig. L)**

IMPORTANT: Make sure that the small drain hole in the rear of the muffler is facing straight downwards when the muffler is installed. **(See Fig. M)**

4. Secure the muffler in place with the supplied clamp as shown, using a 9/16" socket and ratchet, making sure to only tighten the clamp nuts just enough to hold the muffler onto the head-pipe. Note the position and orientation of the clamp. **(See above clamp notes & See Fig. N)**
5. Locate the dB Performance front tailpipe assembly, and another supplied clamp. Slide the expanded end of the tailpipe onto the outlet of the rear muffler, and then place the hanger into the factory rubber grommet as shown. **(See Fig. O & P)**

6. Secure the front tailpipe in place with the supplied clamp as shown, using a 9/16" socket and ratchet, making sure to only tighten the clamp nuts just enough to hold the front tailpipe onto the muffler. (See Fig. Q)
7. Locate the rear tailpipe assembly, and the last of the supplied clamps. Place the hanger into the factory rubber grommet as shown, and then slide the expanded end of the rear tailpipe onto the outlet of the front tailpipe. (See Fig. R & S)
8. Rotate the rear tailpipe assembly until the rearmost section of the pipe is horizontal, and then secure it with the supplied clamp as shown, using a 9/16" socket and ratchet, making sure to only tighten the clamp nuts just enough to hold the rear tailpipe onto the front tailpipe. (See Fig. T)
9. Locate the dB Performance straight tip assembly, which has a clamp built into it. Slide the clamp end of the tip onto the end of the tailpipe. (See Fig. U) Rotate the tip until the dB Performance logo is centered on the top side of the tip. (See Fig. V) Snugly tighten the clamp as shown using a 13mm socket and ratchet, making sure to only tighten the clamp enough to hold the tip in place on the tailpipe. (See Fig. W)
10. Visually inspect the exhaust system position, tip alignment, clamp orientation and position, and exhaust pipe clearance. Make any necessary adjustments at the slip joints.
11. Fully tighten the 14mm bolts that mount both head pipe flanges. Torque to 35 ±5 ft-lbs.
12. Start at the front of the vehicle, and tighten the nuts on the three supplied clamps. Torque the nuts on the clamps to 35 ft-lbs. Finally, tighten the clamp that is built into the tip to 16-20 ft-lbs.
13. It is **STRONGLY SUGGESTED** that all clamps be checked and re-tightened (if necessary) to the recommended torque after initial road testing of the vehicle, as thermal cycling has occurred on the system. Please wait until system has fully cooled to conduct this process.



FIG. I



FIG. J



FIG. K.

FIG. L.

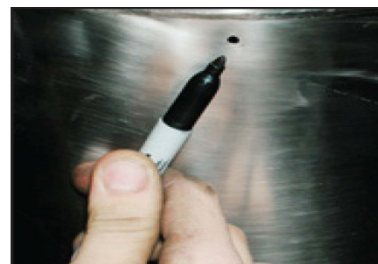

FIG. M.



FIG. N



FIG. O



FIG. P



FIG. Q



FIG. R



FIG. S



FIG. T



FIG. U



FIG. V



FIG. W

DO NOT MAKE ANY MODIFICATIONS TO PARTS AS THIS WILL VOID YOUR WARRANTY. If you have questions, please contact the manufacturer.

During cold weather start-ups, you may experience an exhaust note that is deeper and louder than normal. This is temporary, as the noise levels will return to normal once your engine has reached normal operating temperature.

Immediately following the installation, you may experience a trace of smoke after start-up. **DO NOT** be alarmed. This is normal and temporary due to oil residue from the manufacturing process.