

INSTALLATION INSTRUCTION ENGINE BLOCK HEATER

Subject to alteration without notice

09-28-00

K6858427

Expert Fitment Required

DAIMLERCHRYSLER

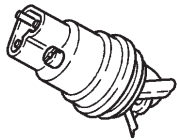

A

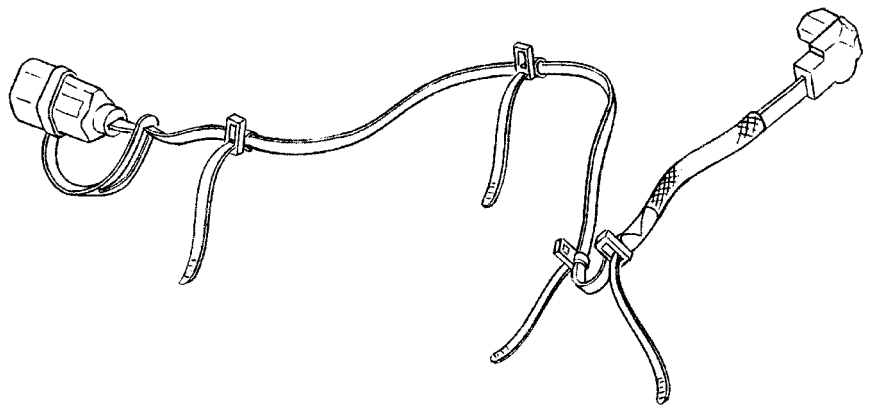

B

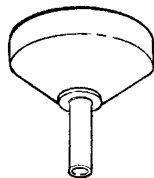
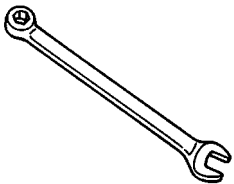

Coolant Salvage
Container

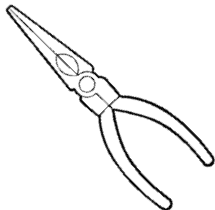
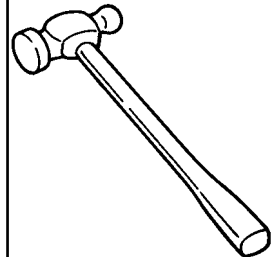
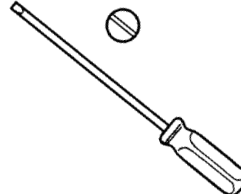

Non-Petroleum
Based Lubricant

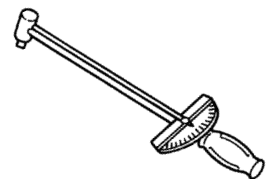

APPLICATION: PT CRUISER

CAUTION! Before connecting the block heater/cord set to a power source, be sure that the element is immersed in coolant. NEVER energize heater in the open air. The element sheath could burst.

- Disconnect air cleaner hose and pull out air cleaner assembly to access the battery. Disconnect and isolate the negative battery cable.
- Drain coolant from the radiator and cylinder block and save for re-use. Refer to cooling system draining procedure in the service manual.

CAUTION! Make sure that vehicle has completely cooled off before starting the install.

- Raise and secure the vehicle on a lift.

1

- Remove two bolts attaching power steering cooler to the vehicle front crossrail.
 - Disengage clip from the cooler lines. Pull cooler down far enough to allow access to the core plug on engine block.
 - Using a long flat blade screwdriver and hammer, carefully strike the bottom edge of the core plug to break it loose.
- CAUTION! Take care that the core plug does not drop inside the engine block.**

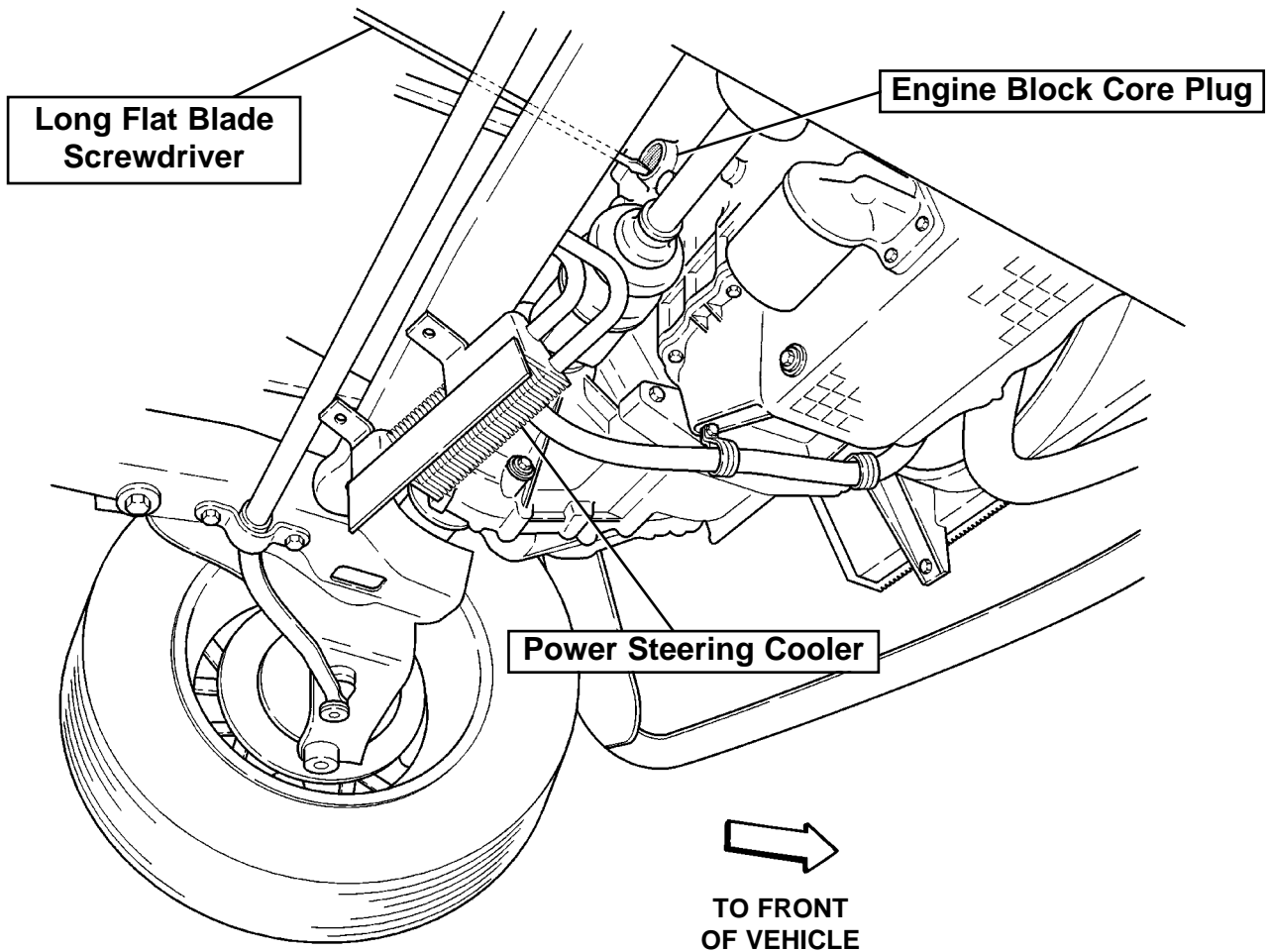

2

- Using pliers, grasp the plug firmly and remove it.
- Clean the machined part of hole; remove burrs, compound, paint, rough spots or sharp outer edges.

- Apply a coating of lubricant to the surface of hole and the "O" ring on the block heater.
- Insert block heater as shown. Push into block until fully seated. Tighten the center screw to 14-19 in.-lbs. **Do not overtighten.**

3

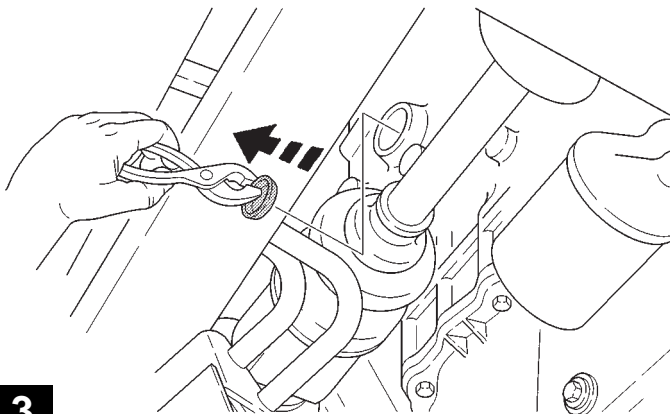

4

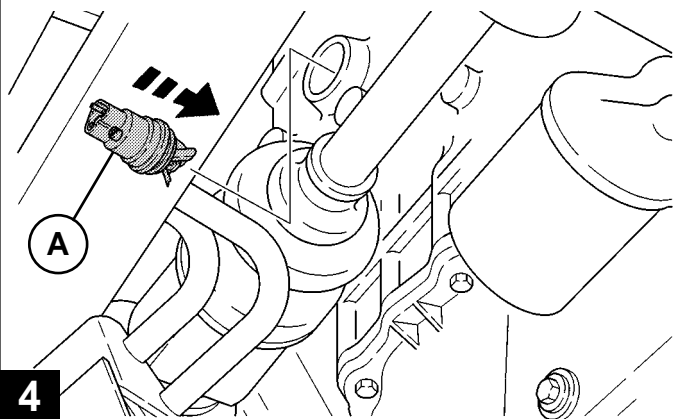

- Plug the cordset firmly into the block heater.
- Remove cap from male receptacle on cordset to ease routing. Save for re-use.
- Route cordset up over the transmission and along the bulkhead harness (at plenum). Secure to engine harness with one in-line tie strap.
- Lower the vehicle and open the hood.

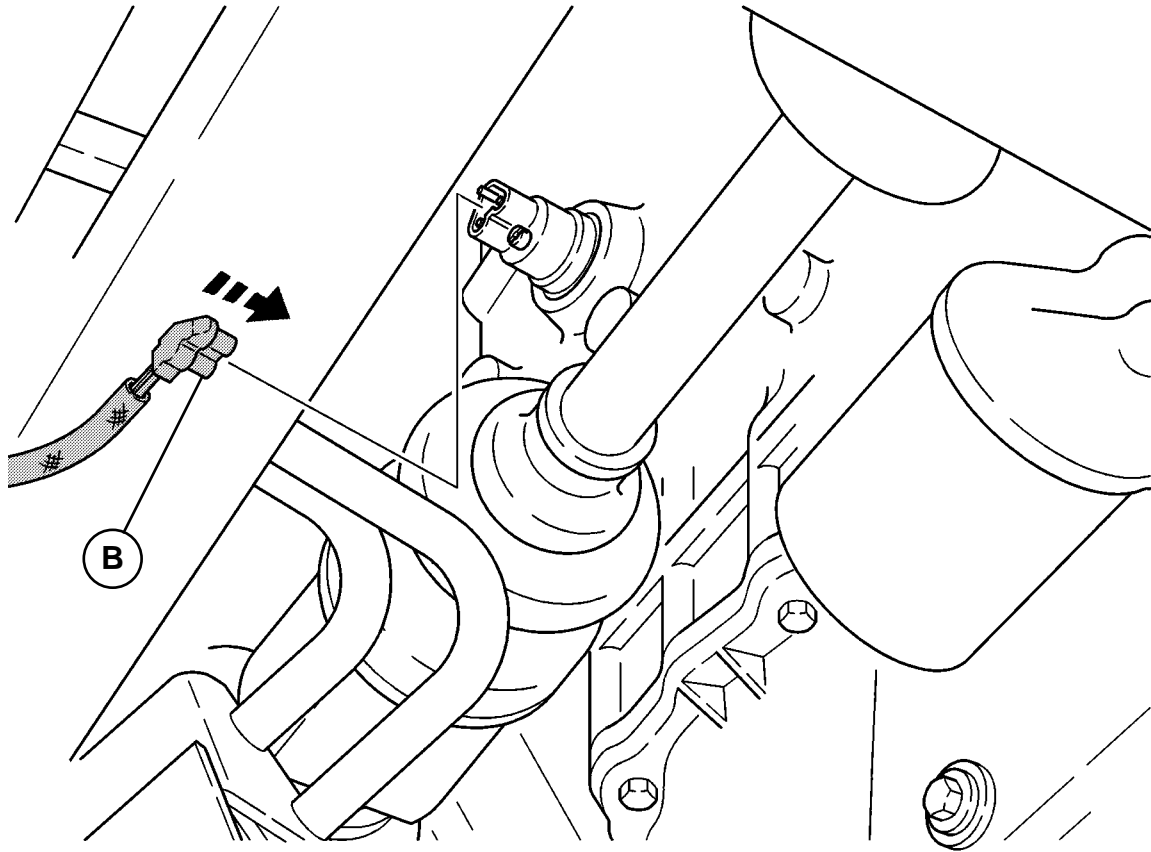

5

Bulkhead Harness

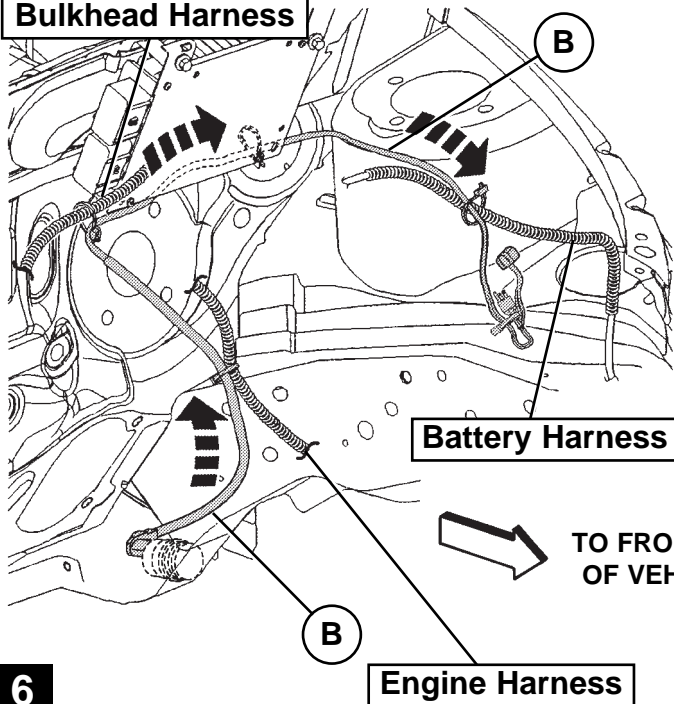

6

- Route cordset upwards and secure to bulkhead harness (under the electronic control module) with two in-line tie straps.
- Route cordset forward in-between battery tray and inner fender. Secure to battery harness with one in-line tie strap.
- Re-install cap to the cordset.
- Re-fill cooling system with the retained coolant.
- Re-connect the negative battery cable.