

# Dee Zee Triangle Trailer Tool Box DZ 91716 / DZ 91717 Installation Instructions

<b>A</b> Triangle Trailer Toolbox  <p style="text-align: right;"><b>X1</b></p>	<b>B</b> 1/4 x 1" Sheet Metal Screw  <p style="text-align: right;"><b>X4</b></p>	<b>C</b> 1/4" Flat Washer  <p style="text-align: right;"><b>X4</b></p>	
---	--	---	--

<b>Tools Required:</b> <b>Outils Nécessaires:</b>	 <b>3/8"</b>	 <b>3/16"</b>
--	---	---

**1** Position the triangle trailer toolbox (A) onto the trailer tongue of your trailer. Drill four 3/16" holes through the bottom of the triangle trailer toolbox (A) and the trailer tongue.

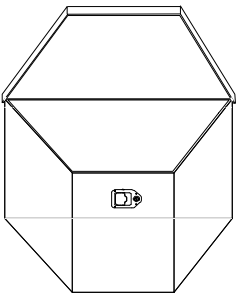
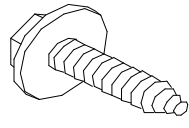
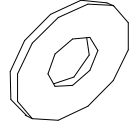
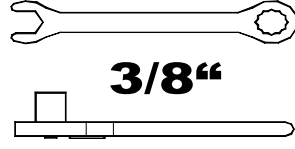
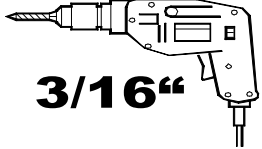
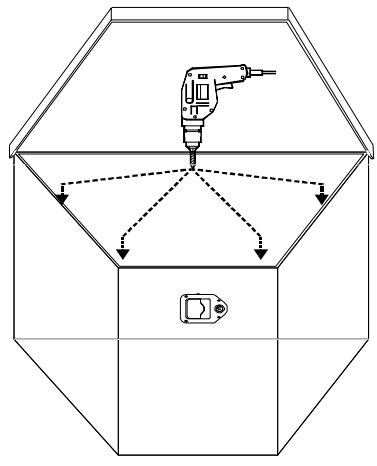

**2** Secure the triangle trailer toolbox (A) to the trailer tongue of your trailer using the provided 1/4 x 1" sheet metal screws (B) and 1/4" flat washers (C). Tighten into place using a 3/8" wrench / socket.

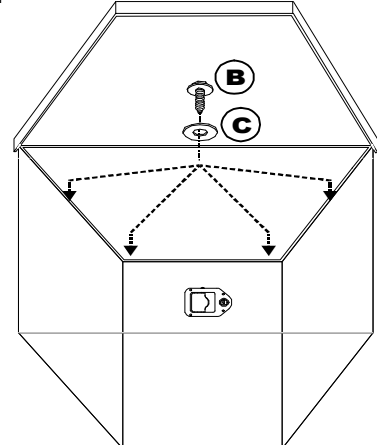

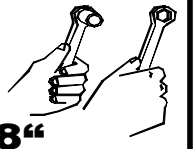
  
**3/8"**

**MAINTENANCE INSTRUCTIONS:** All locks, latches, latching rods, and hinges should be lubricated regularly to assure smooth and proper operation for the life of the toolbox.

**INSTRUCTIONS D'Entretien:** Toutes les serrures, verrous, verrouillant des tiges, et des charnières devraient être lubrifiées régulièrement pour assurer l'exécution sans heurt et appropriée pendant la vie de la boîte à outils.

**Toolbox Latch Assembly**

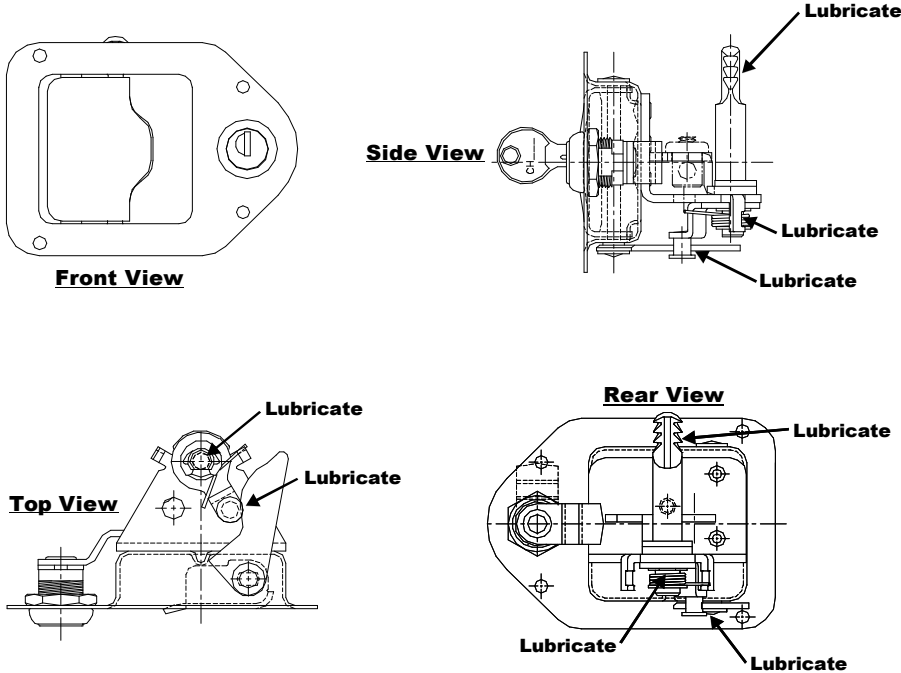

**Toolbox Catch Assembly**

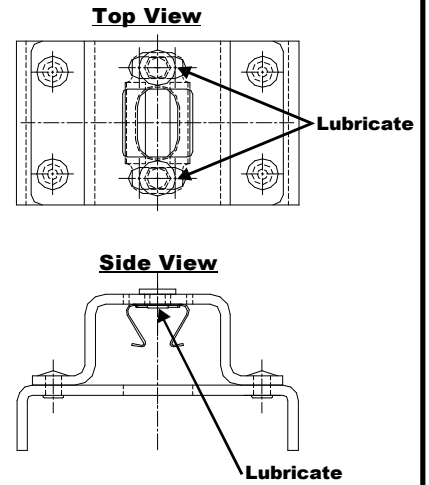

**Ever lose your keys? Save Yourself Time and Trouble?**

Order some extra keys now and have them when you need them. Please fill out and mail this portion to us. We'll send you a couple of extra keys for your Tool Box for just \$5.00 (American).

Name: \_\_\_\_\_

Day Phone: \_\_\_\_\_ - \_\_\_\_\_ - \_\_\_\_\_

Address: \_\_\_\_\_  
 \_\_\_\_\_  
 \_\_\_\_\_

Method of Payment:  
 Cash, Check, or Money Order  
 Master Card  
 Visa

City, State, Zip: \_\_\_\_\_

Expiration Date: \_\_\_\_\_

KEY and LOCK#: \_\_\_\_\_

Card Number: \_\_\_\_\_

Please mail form and payment to : Dee Zee, Inc.  
 OR P.O. Box 3090  
 Fax to: 515-265-7926 Des Moines, IA 50316

**CLEANING INSTRUCTIONS:** To maintain the luster of your tool box, use a mild detergent.

**\*\*Locks are provided as a deterrent to inadvertent opening or easy access to the contents of your toolbox. Contents stored in the toolbox are the responsibility of the user. Dee Zee does not insure loss of contents.**

After drilling, Dee Zee recommends putting a sealant or rust inhibitor around all holes drilled into the body panel of the vehicle.

If you should incur any problems with the installation of this product, please feel free to call us at 1-800-779-8222. So that we may better serve you when you call, please have the W/O#, SEQUENCE#, and the DATE from the label on the outside of the box.

# Replacement Parts for Triangle Trailer Toolbox

## Shocks

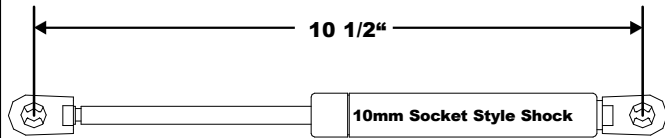

10mm Socket Style Shock					
Shock #	20#	40#	60#	80#	100#
Part Number	SL-3220	SL-3240	SL-3260	SL-3280	SL-32100

## Miscellaneous Parts

**Foam Latch Gasket**  
Part Number: TB85409

**Striker Assembly**  
Part Number: TB85616

**1/4" Flat Washer**  
Part Number: PN 72

**1/4 x 1" Sheet Metal Screw**  
Part Number: PN 97

**Latch Cover Rivet**  
Part Number: PN 285

**Latch Rivet**  
Part Number: PN 157

**Hinge Rivet**  
Part Number: PN 208

**Rear View: Locking Latch**  
Part Number: TB85613

**Rear View: Non-Locking Latch**  
Part Number: TB85614

## Ordering Replacement Parts:

Ordering replacement parts for your Dee Zee single-lid / double-lid toolbox is fast, convenient, and easy. Just call our customer service phone number at 1-800-779-2102 for pricing and ordering information. Please provide the customer service representative with the part number from the above parts list.