

Installation Instructions:

6-116

FORD TRUCK BODY MOUNT KIT

'01-'05 FORD EXPLORER SPORT TRAC



PARTS LIST:

		QTY:
U-68129	SPORT TRAC MNT UPPER A	2
U-68130	SPORT TRAC MNT LOWER A	2
U-68132	SPORT TRAC MNT UPPER B	2
U-68133	SPORT TRAC MNT LOWER B	2
U-68135	SPORT TRAC MNT UPPER C	2
U-68136	SPORT TRAC MNT LOWER C	2
U-68138	SPORT TRAC MNT UPPER D	2
U-68139	SPORT TRAC MNT LOWER D	2
WASH-1161	1/2"X2.500X0.100 FLAT WASH GOLD	2

! Please refer to a factory service manual before any disassembly or reassembling of your vehicle for proper instructions. Check service manual to ensure proper torque specs during installation. **NOTE:** The Prothane Bushings generally do NOT meet in the center. The "crush" or amount the bolt can be tightened is determined by the length of the sleeve.

****Prothane Motion Control highly recommends this and all our polyurethane suspension kits be installed by a qualified technician.****

Installation:

****NOTE:** Before and during install, take care to note all body mount positions and respective parts (mount size/type, washers, spacers, bolts, shims, etc.) as some factory hardware pieces (not included in this kit) may have to be reused. Each vehicle, depending on model will have 3-6 mounts per side located between frame and body.

- 1) **SPRAY** liberally all mounting bolts and nuts to be removed with penetrating oil (ie. WD-40).
- 2) **SUPPORT** vehicle body properly before removing mounts. (**RECOMMENDED:** Use a 2"x4" piece of wood 24" long or any other suitable size between the jack and body panels to spread the load out so as not to damage body panels). If necessary, support the body in several areas.
- 3) **LOOSEN** all nuts and bolts but **DO NOT REMOVE**. Working from one side of the vehicle at a time **REMOVE** the nut and bolt from **ONE** mount location and raise body enough to replace mount, **NEVER HIGHER**. Check other areas of the body for interference problems when raising the body.

-NOTE: If penetrating oil did not work in freeing bolts, use of a torch may be required.-
- 4) **REPLACE** one mount at a time with similar size urethane mounts. If washers/sleeves have been provided, use in combination of original factory metal parts that are not replaced by hardware supplied in kit. **SEE DIAGRAM** for frame position and assembly order.

-NOTE: This kit requires **ALL FACTORY HARDWARE** to be REUSED!-
- 5) After all mounts have been replaced, **TORQUE ALL NUTS AND BOLTS TO FACTORY SPECIFICATIONS**. (Position A: 41 ft/lbs; Position B,C,D: 59 ft/lbs)

-NOTE: RECOMMEND applying blue loctite to threads factory bolts when reinstalling mounts. **RETORQUE** all nuts and bolts after initial settling of mounts (approximately 1000 miles of driving) to insure that fasteners have not come loose.-

FORD BODY MOUNT DISASSEMBLY INSTRUCTIONS

Most Fords use a unique 1pc. stamped washer and sleeve assembly. This type of assembly can be difficult to remove especially on older vehicles. Use this diagram and instructions to facilitate disassembly:

- 1) **REMOVE** body mount bolt from inside of cab.
- 2) **THREAD** a bolt from below into bottom nut/washer assembly until bolt is flush with inside of washer. This is to protect the threads of nut during removal.
- 3) **INSERT** a punch into body mount assembly from inside cab. **DRIVE** bottom washer/sleeve assembly downward away from top assembly.
- 4) Lip on sleeve of bottom stamped washer/sleeve assembly may have become mushroomed especially on older vehicles. **BEFORE** reinstalling this part **REMOVE** mushroomed lip to avoid any interference fit problems.

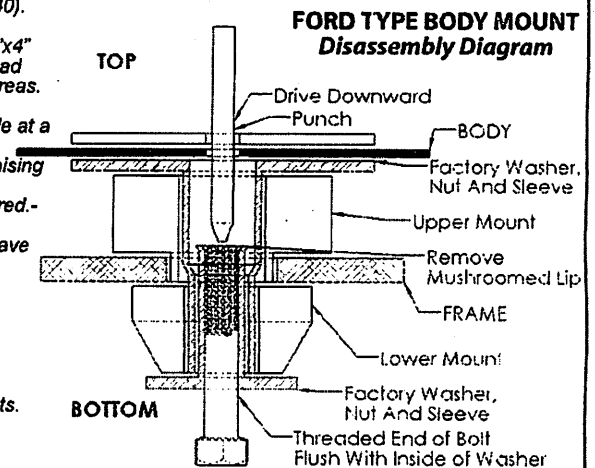

Frame Position Diagram

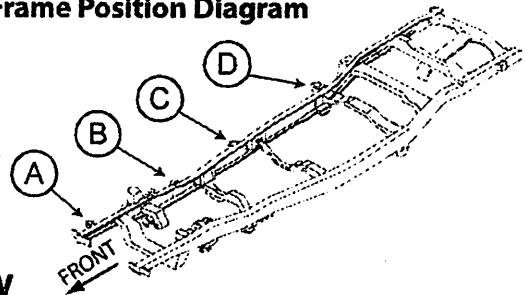

Assembly View

