



Detroit Speed, Inc.
Front Coilover Conversion Kit
2016+ Camaro
P/N: 030333, 030333-D

The Detroit Speed, Inc. 2016+ Camaro Front Coilover Conversion Kit provides bolt-on replacement aluminum strut assemblies that are fully adjustable. The adjustable spindle bracket allows ride height to be adjusted without affecting strut travel as well as easy spring changes. The ride height can also be "fine-tuned" with a coilover adjusting nut on the strut body. In addition, the Detroit Speed strut can achieve more negative camber than the OEM strut. The upper strut mount is replaced with a precision spherical bearing to eliminate compliance and improve response. In addition, the upper mounting plates offer *Speed-LIGN™* technology for quick, easy camber adjustments for track tuning.



Item	Description	Quantity
1	Front Strut Assembly	2
2	Coilover Spring 250# x 2.5"ID x 8"L	2
3	Strut Tower Mounting Plate, LH and RH	2
4	Upper Strut Monoball Mount Assembly	2
5	Lower Strut Mount	2
6	Strut Spring Perch w/Bearing	2
7	Strut Tapered Spacer	2
8	M10 Star Adjuster Assembly	4
9	5/8"L Straight Spacer	2
10	1/4"L Straight Spacer	2
11	Front Coilover Hardware Kit	1
12	Detroit Speed/JRi Spanner Tool	1
13	Instructions	1

Hardware Checklist			
Part Number	Description	Quantity	Check
9303313	Front Coilover Hardware Kit	1	
980075FS	M16-2.0 x 70mm Flange Head Bolt	4	
960071FS	M16-2.0 Flange Lock Nut	4	
960072FS	M6-1.0 Flange Lock Nut	2	
960073FS	5/8"-18 Nylock Jam Nut	2	
960081FS	M12-1.75 Flange Lock Nut	2	
970059FS	M8 Hardened Washer	4	
950101FS	M8-1.25 x 30mm Socket Head Cap Screw	4	
950102FS	M10-1.5 x 40mm Socket Head Cap Screw	4	
950116FS	M10-1.5 x 30mm Socket Head Cap Screw	6	
970031FS	M10 Washer	6	
99030379	Thrust Bearing	2	
99030380	Thrust Washer	4	
031062	Torrington Bearing Set	1	

NOTE: Since the Detroit Speed coilover kit replaces the magnetic ride control, you will need to purchase the X-inengineering Electronics GM shock simulator kit to keep the warning light off on the dash. Visit their site at www.xineering.com.

Installation Instructions:

1. With the vehicle safely up on jack stands, remove the front wheels.
2. Disconnect the front sway bar end link from the OEM strut (Figure 1 on the next page).

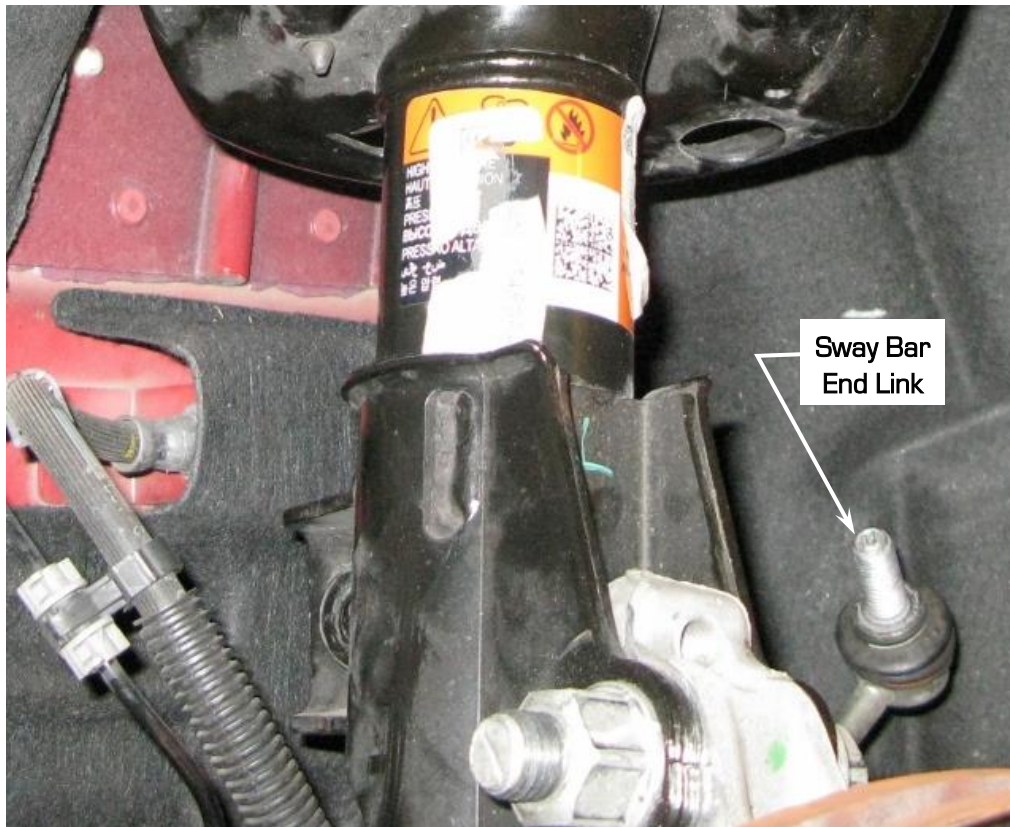

Figure 1 - Disconnect Sway Bar End Link

3. Disconnect the front brake line and ABS wire from each respective tab on the OEM strut (Figure 2). Save the M6 bolt from the brake line tab to be re-used later.

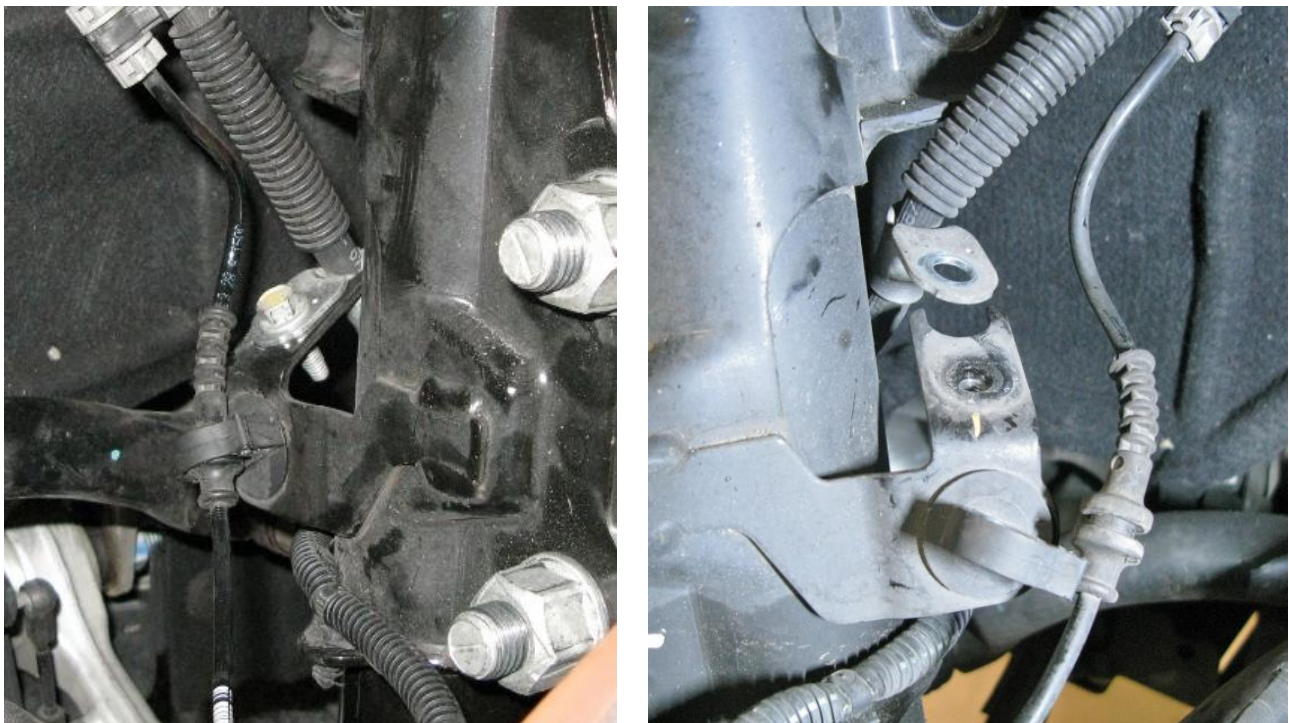

Figure 2 - Disconnect Brake Line & ABS Wire

4. Disconnect the magnetic ride control sensor. Lift up the red lock and pull the connector out (Figure 3).

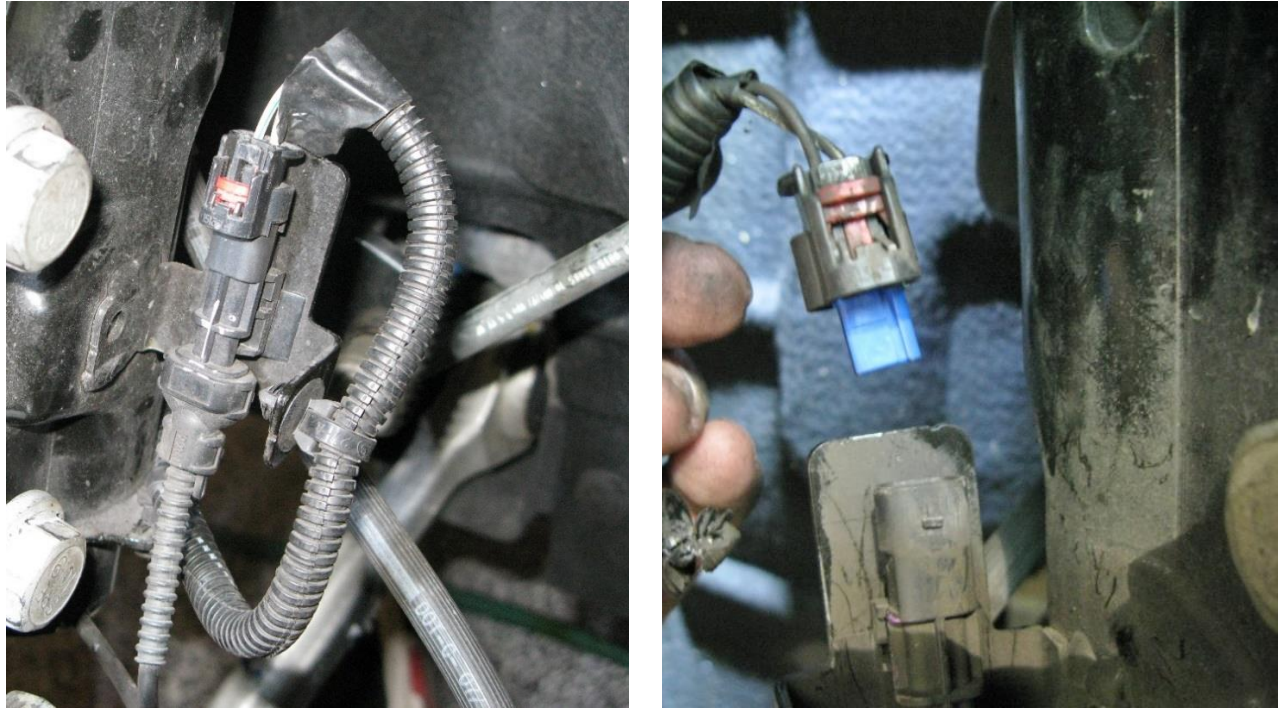

Figure 3 - Disconnect Magnetic Ride Control

5. Place a floor jack under the spindle or lower control arm to support the suspension while the strut is removed. Remove the two M16 nuts & bolts attaching the strut to the spindle using a 21mm and 24mm socket/wrench. At this time the spindle should swing clear of the strut assembly (Figure 4).

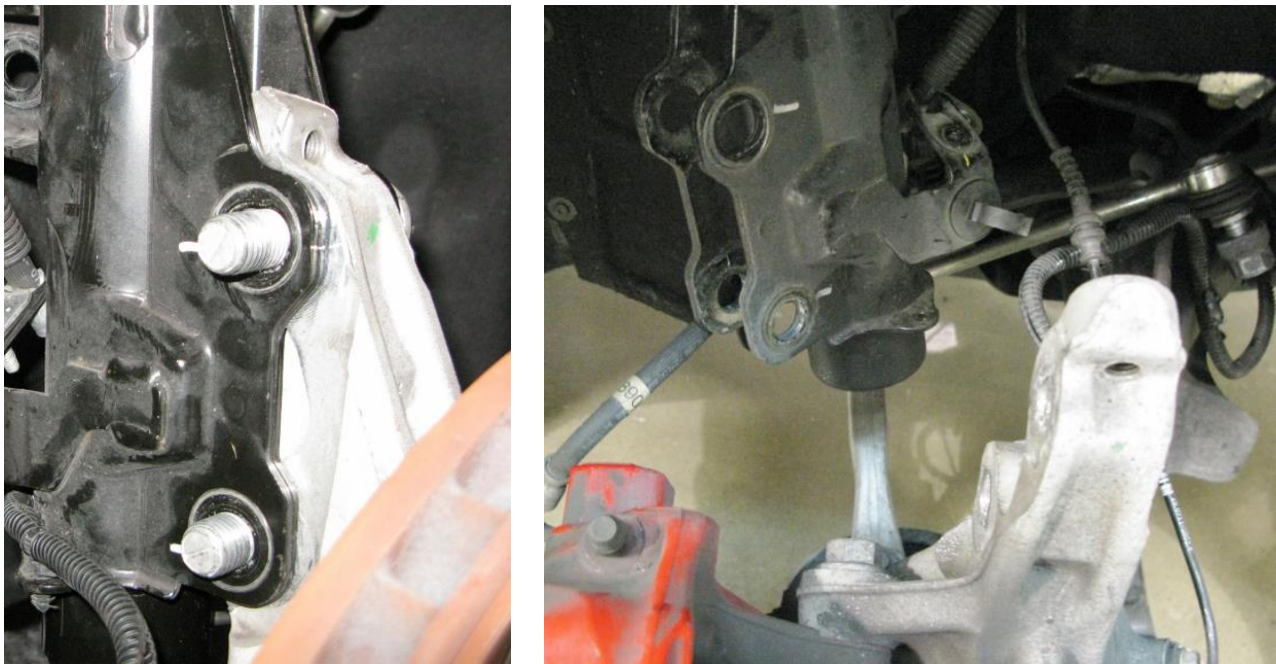

Figure 4 - Remove M16 Nuts & Bolts

6. Remove the strut assembly from the strut tower by removing the three M10 flange bolts using a 13mm socket. Hold the strut assembly with one hand while loosening the bolts so the strut doesn't fall. Remove the OEM strut assembly from the wheel house (Figure 5).



Figure 5 - Remove Strut Assembly

7. Place the lower strut mount underneath the strut tower. Using the 3 provided M10-1.5 x 30mm socket head cap screws and M10 washers, attach the lower strut mount to the strut tower from the top of the strut tower (Figure 6). Apply medium strength blue Loctite 242 to the threads of the bolts. Make sure the slotted holes in the lower strut mount are parallel with the front of the vehicle. Torque the M10 hardware to 35 ft. /lbs.



Figure 6 - Install Lower Strut Mount

NOTE: If you have the optional factory strut tower brace, you can attach it to the strut tower using the new hardware at this time.

8. Bolt the strut tower mounting plate to the lower strut mount using the M8-1.25 x 30mm socket head cap screws and M8 hardened washers (Figure 7 on the next page). Apply medium strength blue Loctite 242 to the threads of the bolts. Make sure you have the left and right hand mounting plate on the correct side. They are notched for the optional factory strut tower brace. Torque the M8 bolts to 27 ft. /lbs.



Figure 7 - Install Strut Mounting Plate

9. The Detroit Speed strut comes pre-assembled up to the point of loading the coilover spring. Install the Torrington bearing set (Figure 8) by installing one thrust washer, followed by the roller bearing and then another thrust washer. Detroit Speed recommends using high pressure grease between the roller bearing and thrust washers. Install the coilover spring onto the strut assembly.



Figure 8 - Torrington Bearing Set

10. Install the upper spring perch over the strut and on top of the coilover spring. Install the thrust bearing set by installing one thrust washer, followed by the thrust bearing and then another thrust washer. Detroit Speed recommends using high pressure grease between the thrust bearing and thrust washers.
11. Place the 1/4" long steel straight spacer over the strut assembly and onto the thrust bearing set. Then install the steel tapered spacer onto the straight spacer.
12. Insert the strut shaft through the upper strut monoball mount assembly making sure that the mount is orientated such that the snap ring for the monoball is on the bottom. Place the 5/8" long steel straight spacer over the strut shaft and thread the 5/8"-18 Nylock nut on the strut shaft.
13. Hold the strut shaft from turning by using a 3/4" wrench on the flats on the shaft between the upper spring perch and the 1/4" straight spacer. Tighten the 5/8"-18 Nylock nut using a 15/16" wrench while holding the 3/4" wrench from turning (Figure 9 on the next page). Torque to 50 ft. /lbs. **CAUTION: When tightening the 5/8"-18 Nylock Nut, failure to hold the shaft from turning too many times while under pressure can cause the inner shaft nut to loosen and fall off. This would result in sending the shocks back to be repaired at the customer's expense.**

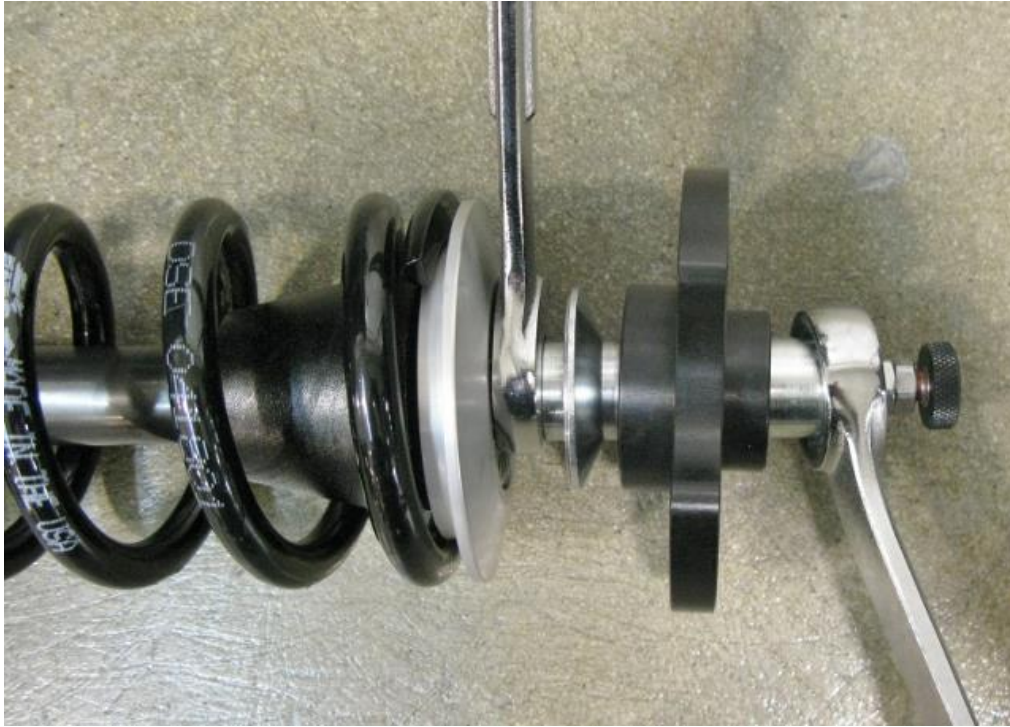

Figure 9 - Tighten Strut Assembly

14. Install the Detroit Speed strut assembly into the strut tower from the bottom side. Secure the assembly to the upper mounting plate with two M10-1.5 x 40mm socket head cap screws and two star adjusters. Set the stars to "0" in the center notch to start (Figure 10). Apply medium strength blue Loctite 242 and torque the M10 bolts to 30 ft. /lbs. **NOTE:** Optional factory strut tower brace shown.

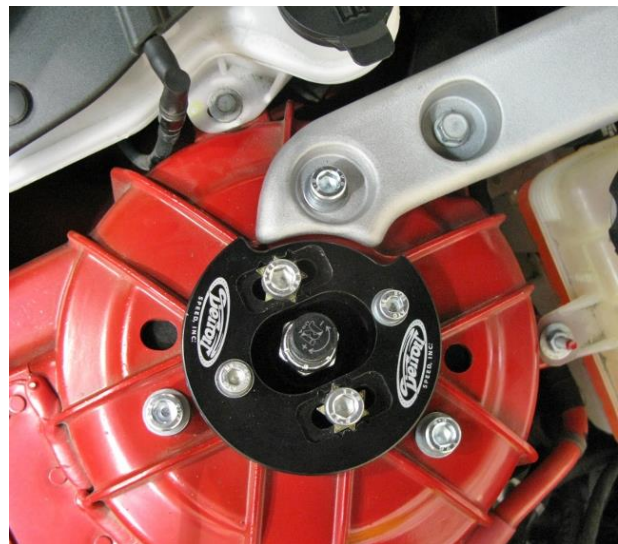
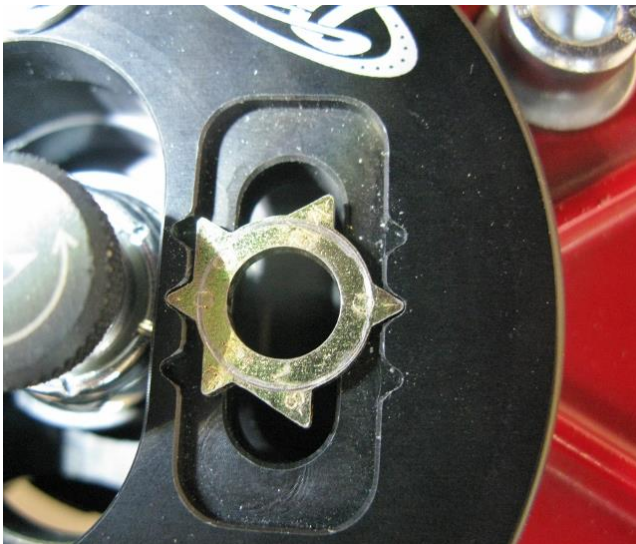

Figure 10 - Install Strut Assembly

15. Turn the coilover nut up to take any free play out of the spring if necessary. Attach the spindle to the new strut using the provided M16-2.0 x 70mm flange head bolts and flange nuts. Make sure the 1/4" camber slug is installed in the top mounting hole facing the rear of the vehicle as shown (Figure 11 on the next page). Torque the M16 nuts to 111 ft./lbs. +80-95°.



Figure 11 – Attach Strut to Spindle

16. Attach the front sway bar end link to the Detroit Speed strut assembly using the provided M12-1.75 flange lock nut (Figure 12). Tighten the end link nut with a wrench while holding the end link from turning with an Allen wrench in the end of the stud. Once the end link is snug, you can torque the end link nut with a socket to 45 ft. /lbs.



Figure 12 – Attach Sway Bar End Link

17. Attach the front brake line to the brake line bracket on the Detroit Speed strut assembly. Install the M6 bolt saved from earlier from the outboard side and secure it with the provided M6 flange nut. Wire tie the magnetic ride control sensor and harness out of the way (Figure 13).



Figure 13 - Attach Brake Line & Tie-up Sensor Harness

18. Detroit Speed recommends using the magnetic ride control shock simulator kit from X-ineering Electronics. Visit their site at www.xineering.com.

19. Repeat these steps for the opposite side of the vehicle (Figure 14).



Figure 14 - Final Assembly

20. Put the front wheels back on and torque the lug nuts to proper OEM specs.
21. Final set the ride height using the coilover nuts. Lock the coilover jam nut and set screws when finished. With the vehicle assembled with all components installed, adjust the vehicle ride height. Before adjusting the ride height, Detroit Speed recommends cleaning the threads of the shock. Once the threads are clean, Detroit Speed recommends applying dry bicycle chain lube to the threads of the shock body before adjusting the spanner nut and compressing the coilover spring. Allow the chain lube to dry before adjusting the spanner nut. If you have the non-adjustable shocks, the spanner nut has a soft tip set screw that will need to be tightened before the vehicle is driven. **NOTE:** Detroit Speed does include a Spanner Tool (P/N: 031060) to adjust ride height as shown in Figure 15.



Figure 15 - Detroit Speed Spanner Tool

22. Have a professional alignment completed following the specifications that Detroit Speed recommends for settings for performance street use (Figure 16) and settings for track use on street tires (Figure 17). **NOTE:** Increase camber for non-DOT racing tires.

Alignment Specifications	
Front	
Camber	-0.50° (-0.25° to -0.75°)
Caster	6.25° (Can be adjusted with DSE caster kit)
Toe	1/16" Toe-in (1/32" to 3/32")

Figure 16 - Specifications are listed as nominal with a range in parentheses

Alignment Specifications	
Front	
Camber	-1.5° (-1.0° to -2.0°)
Caster	6.25° (Can be adjusted with DSE caster kit)
Toe	1/16" Toe-Out (1/32" to 3/32")

Figure 17 - Specifications are listed as nominal with a range in parentheses

ADJUSTMENT STAR IS SET ON "0" IN THE CENTER NOTCH. MOVING THE STAR TO THE NEXT NOTCH MOVES THE STRUT 1/4" FROM CENTERLINE.

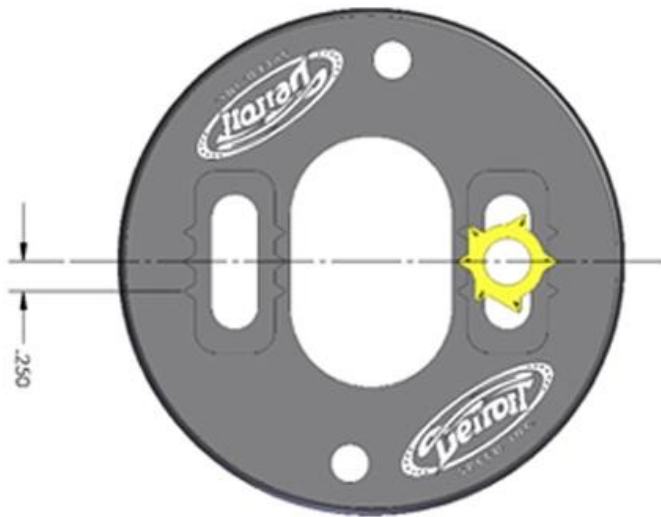

ADJUSTMENT STAR IS ROTATED TO A 1/16" MARK BUT REMAINS IN THE CENTER NOTCH. THIS MOVES THE STRUT 1/16" FROM CENTERLINE.

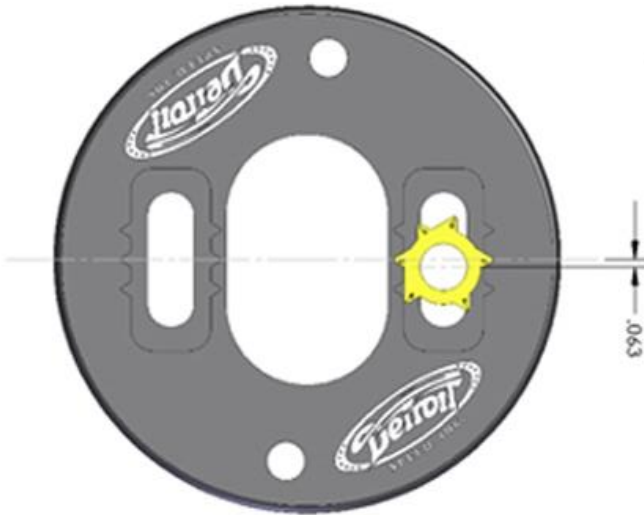

ADJUSTMENT STAR IS ROTATED TO A 1/8" MARK BUT REMAINS IN THE CENTER NOTCH. THIS MOVES THE STRUT 1/8" FROM CENTERLINE.

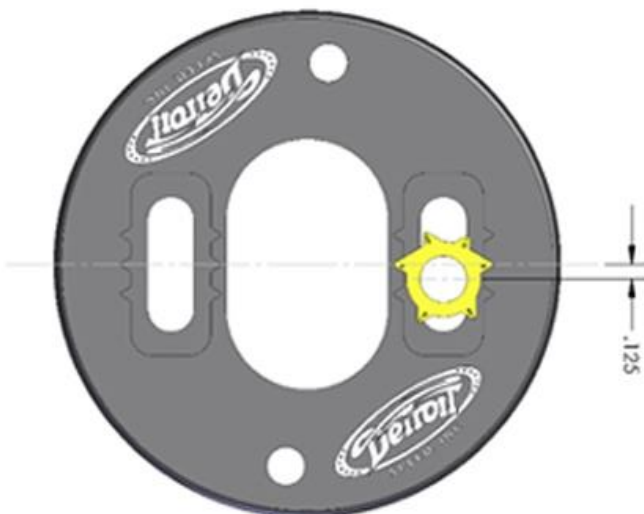

USE ANY COMBINATOIN OF STAR ROTATION AND NOTCH POSITION TO MOVE THE STRUT TOP "IN & OUT" FOR CAMBER ADJUSTMENT. EACH 1/16" OF STAR MOVEMENT CHANGES THE CAMBER ANGLE AT THE WHEEL BY APPROXIMATELY 0.15 DEGREES.

IT IS RECOMMENDED TO INITIALLY SET THE CAMBER WITH THE SLUGS AT THE SPINDLE BOLTS AND THEN USE THE ADJUSTMENT STARS IN THE STRUT MOUNTING PLATES FOR "FINE-TUNING" AND QUICK TRACK ADJUSTMENTS.

23. Refer to the following information for adjustment procedures for the single and double adjustable coilover shocks.

Detroit Speed Single Adjustable Shocks

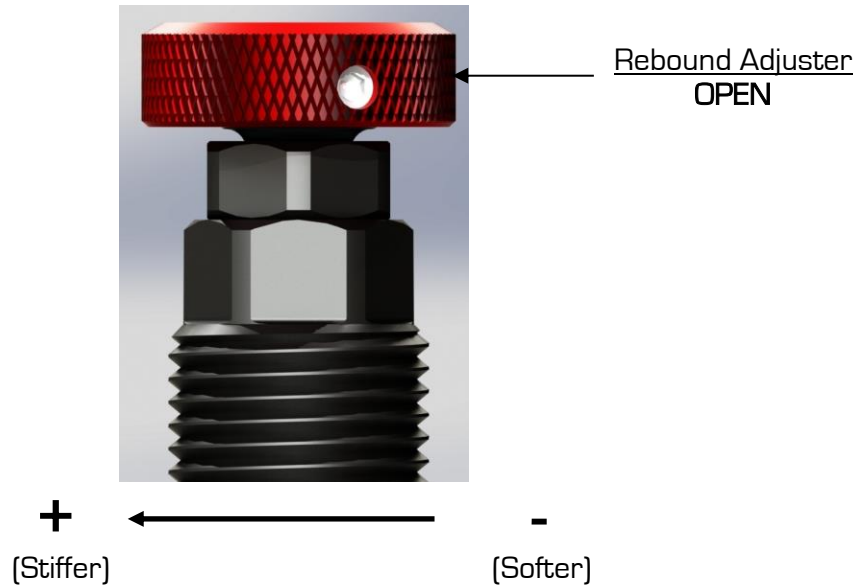

To change from the recommended “Detroit Tuned” valving, adjustments can be made independently to the rebound setting. The rebound is controlled by the knob at the upper strut mount (Strut is mounted body side down). The knob rotates clockwise (+) to increase the damping and counterclockwise (-) to decrease the damping.

To return to the Detroit Speed recommended settings, turn the knob clockwise (+) to full damping. Once at full damping, turn counterclockwise (-) to reach the recommended settings.

Rebound (Shaft Knob)..... 15 Open (counterclockwise)[-]

Detroit Speed Double Adjustable Shocks

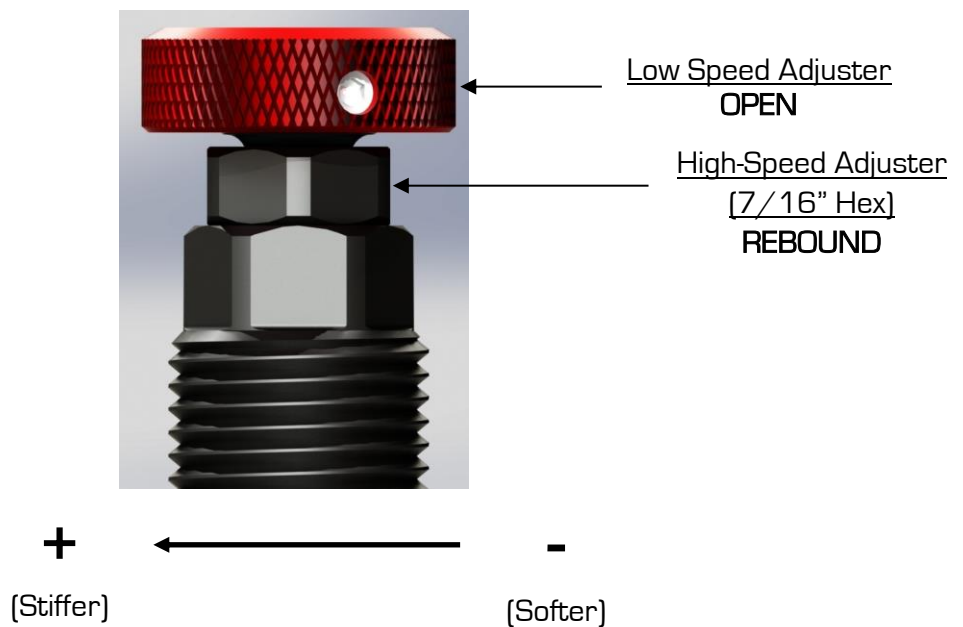

To change from the recommended “Detroit Tuned” valving, adjustments can be made independently to both the high and low speed settings. The rebound is controlled by the sweepers at the upper shock mount. The sweepers rotate clockwise (+) to increase the damping and counterclockwise (-) to decrease the damping.

The high-speed adjuster is a “sweep” style adjuster and the adjustment is measured by how many hex “flats” pass a given point. The high speed sweeper is directly below and is turned with a 7/16” wrench. The high-speed adjuster has 14 flats and is at its full soft position when the hex is bottomed out against the shaft end. The high-speed adjusters reference position is full soft and referred to as +0 (+0 = full soft, +14 = full stiff). Mark a line for reference to keep track of your adjustments.

The top knob is the low speed sweeper and can be turned by hand. It is a “clicker” style adjuster meaning that its adjustment is measured by detent grooves located inside the high-speed shaft and has 30 clicks. It uses a right-hand thread in its operation which means; as you increase low-speed, the adjuster will move down. The low speed adjuster’s reference position is full stiff and referred to as -0 (-0 = full stiff, -30 = full soft). The adjuster is at full stiff when it cannot turn towards the stiff position anymore. **NOTE: Do not exceed 30 clicks on the low speed screw. When turning to full soft, as soon as you feel clicks stop, stop turning and return to the last clicking setting. This is the end of your adjustment.**

NOTE: The low-speed adjustment does not change when adjusting the high-speed, even though the adjuster turns when adjusting the high-speed shaft.

When adjusting the low speed rebound start at full (+) position, when adjusting the high speed rebound start at full (-) position. To return to the Detroit Speed recommended settings turn the sweeper clockwise(+) to full damping for the low speed setting, and counterclockwise (-) to full damping for the high speed setting. Once at full damping, turn counterclockwise (-) for the low speed setting, and clockwise (+) for the high speed setting to reach the recommended settings.

Low Speed Rebound (Sweeper)..... 15 sweeps (counterclockwise)(-)
High Speed Rebound (Sweeper)..... 4 sweeps (clockwise)(+)

Detroit Speed Recommended Settings

Once again, we appreciate your business.
If you have any questions before or during the installation of this product please contact
Detroit Speed at tech@detroitsspeed.com or 704.662.3272

Legal Disclaimer: *Detroit Speed, Inc. is not liable for personal, property, legal, or financial damages from the use or misuse of any product we sell. The purchaser is solely responsible for the safety and performance of these products. No warranty is expressed or implied.*