



Detroit Speed, Inc.
Selecta-Speed Wiper Kit
 1975-1977 Camaro – Non Recessed Park
 1978 Camaro – Non Recessed Park
 P/N: 121406, 121408

A downpour of rain will no longer hinder your ability to clearly see the road. This Detroit Speed Inc. Selecta-Speed Wiper Kit provides you with the performance and convenience of a late model wiper system in a package that easily and cleanly mounts in your 1975-78 Camaro.



Figure 1 - P/N: 121406

Item #	Description	Quantity
1	Wiper Motor Assembly w/ Adapter Plate	1
2	Wiper Control Module w/ Mounting Plate	1
3	Wiper Harness	1
4	Wiper Switch Assembly	1
5	Wiper Knob w/ Set Screw	1
6	Wiper Module Mounting Plate	1
7	Wiper Switch Adapter Plate	1
8	1-1/4" Firewall Grommet	1
9	10-24 x 3/4"L Stainless Steel Screws	3
10	3/8" AN Stainless Steel Washer	1
11	Instructions	1

This kit features a seven speed wiper system with five delays, a low speed, and a high speed. A CNC aluminum adapter plate mounts the wiper motor to the stock firewall bolt pattern. The new pitman arm, included in the kit, bolts directly to your existing wiper linkage. A rotary switch with a billet aluminum knob is also included, along with the complete wiring harness.

This kit does feature a washer pump option as the wiper switch does have a push button function. The wiring harness/control module is equipped with a power and ground wire to install an inline electric washer pump. DSE does offer a washer pump kit available as part number 121102.

Installation Instructions:

1. Before beginning, please ensure that the parts included with your kit match the parts list above. Ensure that the factory wiper system is in its "Parked" position. Disconnect the battery power by removing the negative battery lead from the battery. Mark the position of the wiper arms by placing masking tape on the windshield. This will assure the arms are accurately replaced. Remove the wiper arms, washer hoses, and cowl panel from the vehicle.
2. Disconnect the wiper linkage from the wiper motor pitman arm and remove the stock wiper motor from the firewall.
3. The original wiring will not be used with the new Selecta-Speed Wiper Kit. A custom harness is provided to replace the original. **NOTE: If you decide to cut the old wires, please pay special attention to properly terminate the wire ends to avoid possible shorting.**
4. Mount the new wiper assembly to the firewall using the three supplied 10-24 x 3/4"L" stainless steel allen screws. The adapter plate will mount to the firewall using the original wiper motor weld nuts in the firewall (Figure 2 & 3).

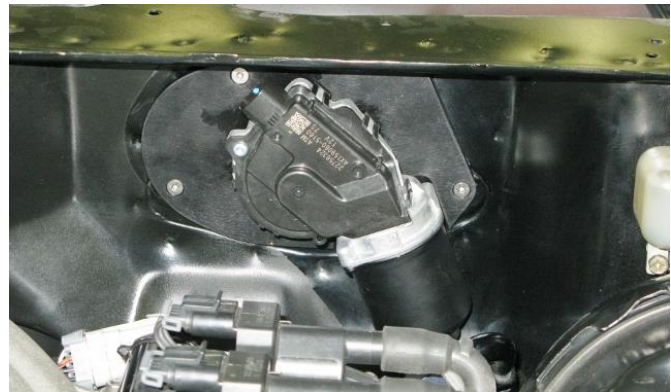

Figure 2 - Wiper Motor Orientation (P/N: 121406 Shown)



Figure 3 - Wiper Motor Orientation (P/N: 121408 Shown)

- Attach the new pitman arm to the original wiper linkage (Figure 4). **NOTE: The Selecta-Speed wiper kit is shipped with the pitman arm in the "parked" position.** Do not move the pitman arm by hand to attach the wiper linkage. If the pitman arm is moved from the original "parked" position from DSE, it may result in the wiper blades stopping in the wrong spot on the windshield.



Figure 4 – Attach Pitman Arm to Wiper Linkage

- The Selecta-Speed switch will replace the stock switch. Remove the stock wiper switch from the dash and remove the connector. Tie up the original wiring under the dash, if desired.
- Mount the switch in the dash. Use the DSE supplied switch alignment plate to mount the switch in the stock location using the provided switch fasteners (Figure 5). Position the switch anti-rotation tab into the anti-rotation hole located in the switch adapter plate.

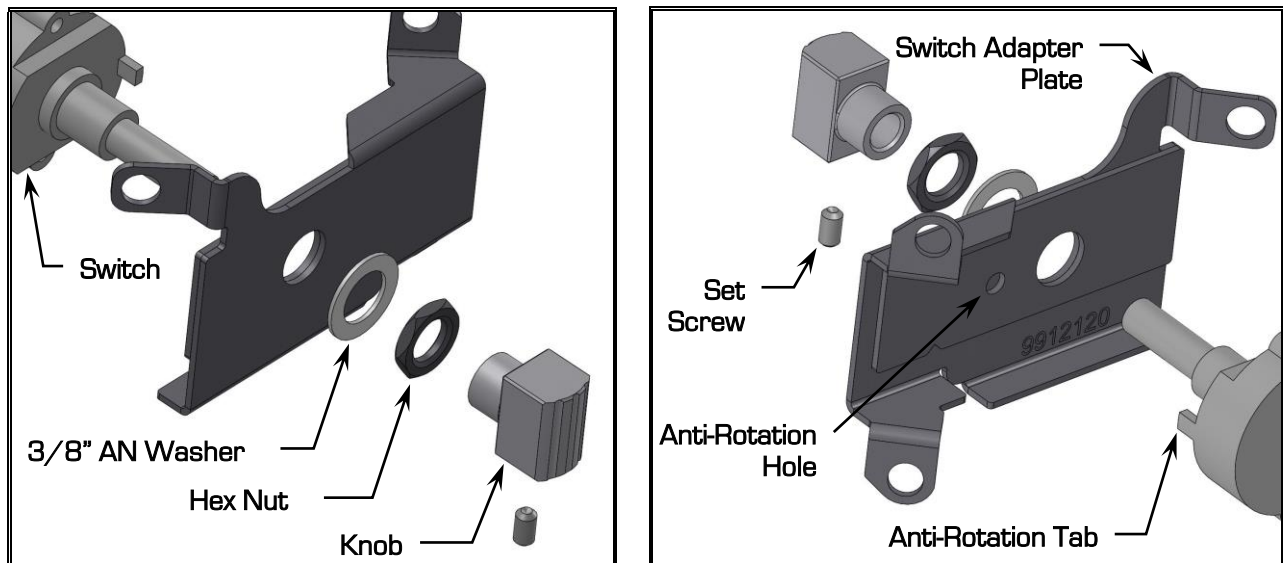

Figure 5 – Selecta-Speed Wiper Switch Installation

- Place the 3/8" AN washer and the hex nut onto the switch shaft and tighten the nut. Slide the wiper knob onto the switch shaft. Align the set screw with the flat on the switch shaft and tighten. **NOTE: Make sure the set screw locks onto the flat on the switch shaft.**
- Route the wiper motor connector side of the wiring harness (Figure 6 on the next page) through the firewall using an existing hole. You may need to open up the diameter of this hole using a 1-1/4" drill bit or Uni-Bit in order to allow the wiper motor connector to pass through the firewall.



Figure 6 - Wiper Motor Connector

10. A rubber grommet is already installed on the wire loom for the wiper motor wires. Once there is enough of the loom through the firewall to connect to the wiper motor, move the grommet on the loom and install it into the firewall to seal the engine compartment from the inside of the vehicle.

11. Install the wiper motor connector to the wiper motor (Figure 7).



Figure 7 - Install Wiper Motor Connector (P/N: 121406 Shown)

12. The DSE Selecta-Speed harness does include a weather pack connector to install an optional electric inline washer pump into your vehicle (Figure 8). DSE does offer a washer pump kit you can purchase separately as part number 121102.



Figure 8 - Washer Pump Connection

13. If you do not want to use the washer pump feature, you can tie wrap this connector/loom up under the dash. If you would like to use this option, use an existing hole or drill a new hole in your firewall to pass the connector through the firewall. You will need a 1-1/8" diameter hole in order to use the provided 1-1/4" rubber grommet. If you have purchased the DSE washer pump kit, use the instructions from that kit to complete the washer pump kit installation.
14. Install the wiper control module onto the module mounting plate using the provided 8-32 hardware if not already assembled from DSE (Figure 9). Do not overtighten.



Figure 9 - Control Module & Mounting Plate

15. Remove the screw at the bottom of the left hand side of the dash that holds the 2 dash sections together. Mount the mounting plate and the module at the bottom of the dash using the screw that was removed (Figure 10).

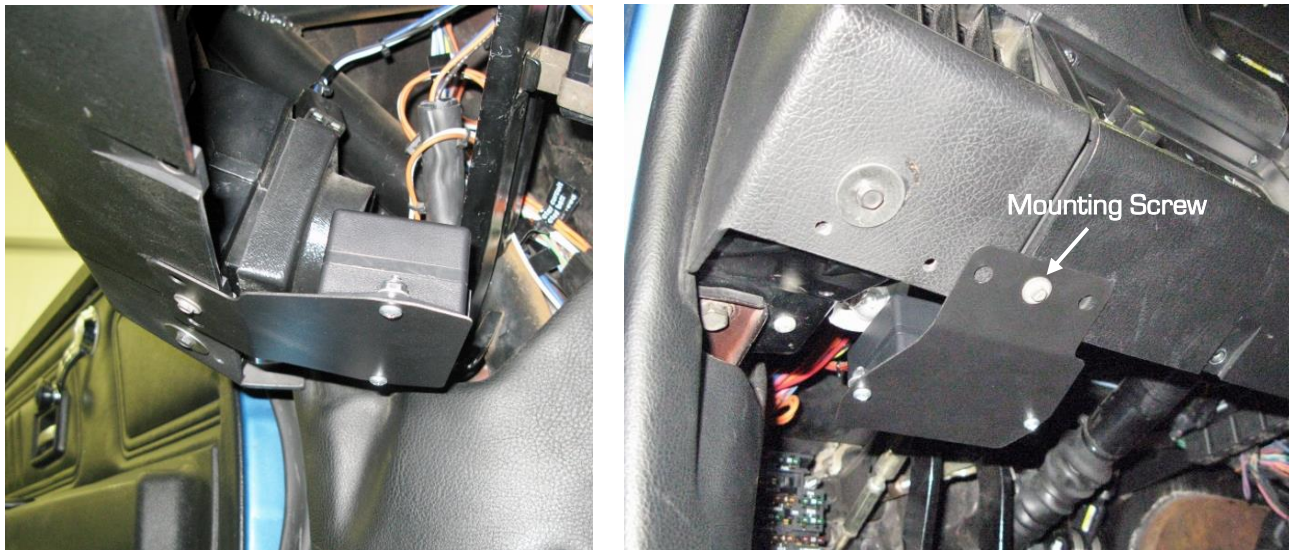

Figure 10 - Install Module & Mounting Plate

16. With the wiper control module mounted in place, plug in the wiper switch and wiring harness connectors into the control module (Figure 11).

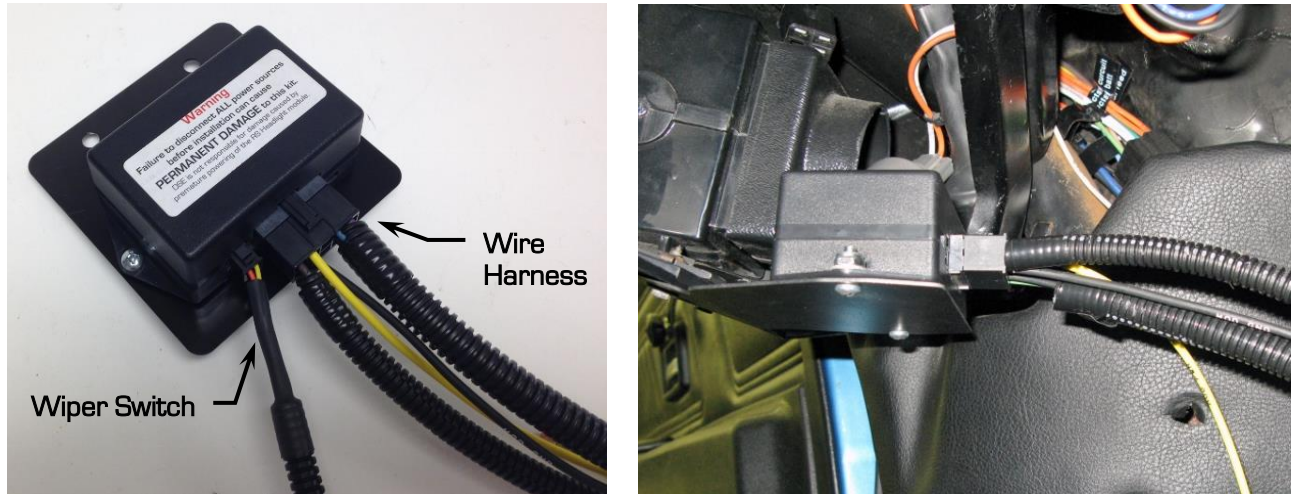

Figure 11 – Connect Wiper Switch & Harness to Module

17. Connect the yellow wire under the dash to a 12V ignition or accessory switched source. [Circuit is active when the key is in the run position]. This lead is supplied with an inline 30 amp ATO fuse.
18. Connect the black wire with the round eyelet to a ground located under the dash. Make sure a proper ground is obtained by removing any rust or paint from the metal.
19. Connect the negative battery lead and test the wiper system. Upon a successful test, the wiper conversion is now complete. Secure the new wiring harness under the dash and in the engine compartment. Re-install the cowl panel and wiper arms along with any other components that have been removed.

NOTE: In some cases high energy ignition systems have caused interference with the correct operation of the Selecta-Speed Wiper Kit due to spark plug wires routed close to the wiper motor. If this occurs, re-routing your spark plug wires may be necessary.

If you have any questions before or during the installation of this product please contact Detroit Speed Inc. at info@detroitsspeed.com or 704.662.3272

Legal Disclaimer: *Detroit Speed, Inc. is not liable for personal, property, legal, or financial damages from the use or misuse of any product we sell. The purchaser is solely responsible for the safety and performance of these products. No warranty is expressed or implied.*