



## Supplemental Fuel Pump Kit '07-'09 GM Truck 4.8L, 5.3L, 6.0L & '07-'08 6.2L Non Flex-Fuel Installation Instructions

**PLEASE** study these installation instructions carefully before beginning the installation. The Supplemental Fuel Pump Kit installation is complex but can be accomplished with common tools and automotive service procedures. However, it is recommended to have a strong familiarity with working on automotive fuel systems before attempting this installation. If you do not feel comfortable performing this installation or have never worked with automotive fuel systems before, it is highly recommended to have the installation completed by a qualified mechanic with access to a service lift and a strong familiarity with automotive service procedures. If you have any questions, please call our **Technical Hotline at: 1-800-416-8628**, Monday - Friday, 7:00 am - 5:00 pm, Pacific Standard Time.

**WARNING: Proper installation is the responsibility of the installer. Improper installation will void the manufacturer's warranty and may result in poor performance and engine or vehicle damage.**

- **DESCRIPTION:** These supplemental fuel kits contain replacement fuel pumps, fuel level senders, fuel pressure control modules and injectors (#15791 Only). These upgrade kits are ideal for GM Trucks utilizing the #1578 and #1579 E-Force supercharger systems. These system are not needed and will not work on Flex- Fuel models.

**15781** - '07-'09 4.8L/5.3L Crew/Extended Cab Models Except Long Beds

**15782** - '07-'09 4.8L/5.3L Standard Cab Models and All Long Beds

**15791** - '07-'09 6.0L/'07-'08 6.2L Crew/Extended Cab Models (Includes Injectors and Injector O-rings)

*Kit includes the following:*

- |   |   |
|---|---|
| <input type="checkbox"/> 1 - Fuel Pump                    | <input type="checkbox"/> 8 - Injectors (P/N 15791 ONLY)         |
| <input type="checkbox"/> 1 - Fuel Level Sending Unit      | <input type="checkbox"/> 8 - Injectors O-rings (P/N 15791 ONLY) |
| <input type="checkbox"/> 1 - Fuel Pressure Control Module | <input type="checkbox"/> 1 - TMAP Harness (P/N 15791 ONLY)      |

*Tools Required:*

- |   |  |
|---|--|
| <input type="checkbox"/> GM J 45722 Fuel Sender Lock Ring Wrench<br>OR Equivalent | <input type="checkbox"/> Compressed Air                            |
| <input type="checkbox"/> Feeler Gage: .41 mm (.016 in)                            | <input type="checkbox"/> Truck Bed Stands OR Equivalent            |
| <input type="checkbox"/> Long Breaker Bar   | <input type="checkbox"/> Torx Bit Set                              |
| <input type="checkbox"/> Ratchet 1/2", 3/8", Extensions                           | <input type="checkbox"/> Small Flat Head Screwdriver               |
| <input type="checkbox"/> Service Lift OR Equivalent                               | <input type="checkbox"/> Three Friends (To Lift Bed) OR Equivalent |

- The procedures for installing the supplemental fuel pump are identical to the OE. It is recommend that you refer to the vehicle's service manual on specific details on how to remove and install the new fuel pump module.
- Prior to starting this installation, make sure that the fuel level in the tank is below an 1/8 tank. This will reduce the risk of toxic vapors, spillage, as well as make the fuel tank easier to remove (if applicable).

***Always work in a well-ventilated area when working with gasoline as the vapors are toxic and are highly flammable. Be aware of any sources of heat or sparks, such as drop lights or space heaters. Do not smoke and do not allow those around you to smoke during this installation.***

### **INSTALLATION PROCEDURE**

***It is critical to install the supplemental fuel tank module on a vehicle that is able to start once the installation is complete. Once the supplemental fuel tank module is installed, you must start the vehicle to check for leaks and Diagnostic Trouble Codes. This process can be completed prior or after the supercharger installation. If performed after the supercharger installation, DO NOT DRIVE the vehicle until the supplemental fuel pump kit is installed.***

The following instructions highlight the fuel tank module replacement procedure via bed removal.

**NOTE:** Removing the fuel tank to service the fuel pump module is possible. Please refer to your service manual for the fuel tank removal procedure.

Prior to removing the truck bed, setup the bed stands in an area where you can set the bed once removed.

1. Disconnect the Negative (-) terminal from the battery.
2. Open the gas door and unbolt the filler neck from the bed. Now remove the body pin with a small flathead screwdriver.
3. Using a 10mm socket, remove the ground strap secured to the gas filler neck and frame
4. Using a 21mm socket and extension, unbolt the bed from the frame. There are eight bolts located along the frame: two on the front of the bed, four along the middle section and two (2) at the rear underneath the tailgate area.
5. Disconnect the taillight harness from the chassis harness.
6. With the assistance from your friends, or equivalent, lift the bed up vertically, making sure there are no leftover connections. Pull the bed up and rearward, making sure to clear the bumper and the wheels. Then place the bed on the bed stands.
7. Using compressed air, clean the fuel and evaporative emission (EVAP) connections and surroundings prior to disconnecting lines in order to avoid possible system contamination.
8. Disconnect the fuel feed pipe, two EVAP pipes, the power harness and the fuel tank pressure sensor connector from the fuel tank module.

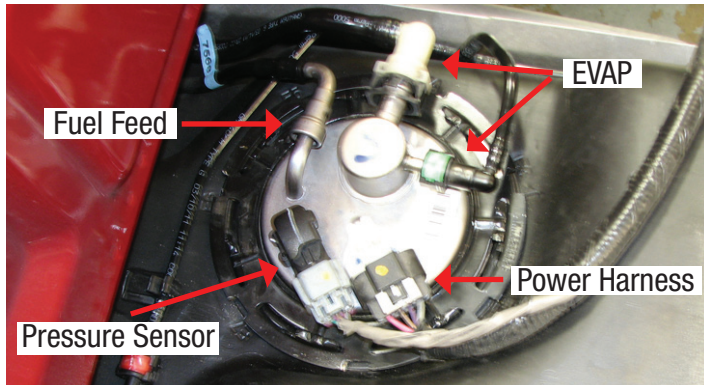

9. Move the fuel feed pipe, the EVAP pipes and harness out of the way.
10. Install a J 45722 fuel tank module lock ring tool or equivalent to the module's lock ring.

**CAUTION:** DO NOT damage the lock ring. DO NOT use any impact tools. DO NOT use a hammer and screwdriver to remove the lock ring as they will damage the lock ring. Significant force will be required to release the lock ring. Using a long breaker bar is highly recommended.

11. Using the J 45722 and a long breaker bar, rotate the lock ring counterclockwise to unlock the fuel tank module lock ring.

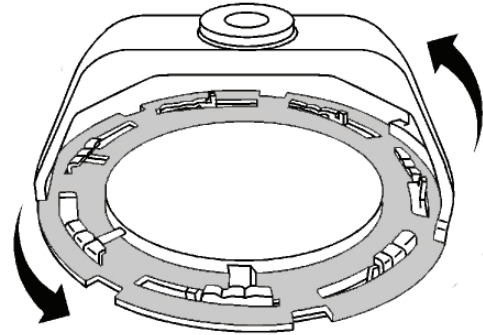

12. Remove the J 45722 and the lock ring.
13. Slowly lift up the module until the float arm is visible.
14. Tilt the module to remove the fuel from the reservoir bucket then fully remove the module. Discard any fuel leftover in the module reservoir bucket.
15. Remove and discard the fuel tank module O-ring seal as a new one is provided in this kit.

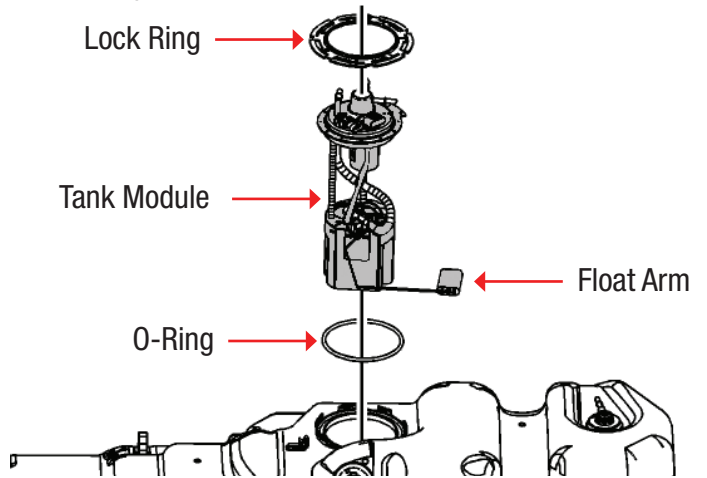

**NOTE:** Some lock rings were manufactured with "DO NOT REUSE" stamped into them. These lock rings may be reused if they are not damaged or warped.

16. Inspect the lock ring for damage due to improper removal. If damage is found, install a NEW lock ring.
17. Check the lock ring for flatness. Place a lock ring on the flat surface and measure the clearance between the lock ring and the flat surface using a feeler gage at all 7 points.

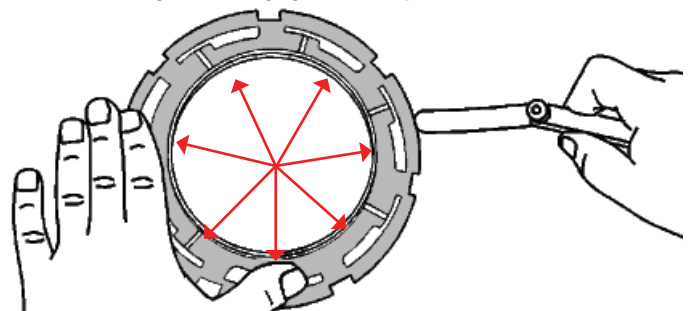

18. If warpage is less than .41 mm (.016 in), the lock ring does not require replacement. If warpage is greater, the lock ring must be replaced.

19. Install the provided float level sending unit onto the new fuel tank module. Now plug in the sending unit's harness into the fuel tank module.

20. Reverse the disassembly procedure to install the new fuel tank module. *DO NOT REINSTALL THE BED YET.*

**NOTE:** *If the factory fuel tank pressure sensor connector does not fit onto the new fuel tank pressure sensor, remove the sensor from the old fuel tank module and install it onto the new fuel tank module.*

21. Remove the spare tire and disconnect the chassis harness from the fuel pressure control module.

22. Using a Torx T-30, remove the three (3) bolts securing the fuel pressure control module to the chassis.

23. Install the supplied fuel pressure control module reversing the removal process.

24. Reinstall the Negative (-) terminal on the battery and start the vehicle. Check for fuel leaks and repair if present. Check for Diagnostic Trouble Codes, if present. If non are present, reinstall the spare tire and the bed.



**Edelbrock LLC • 2700 California St. • Torrance, CA 90503**  
**Tech-Line: 1-800-416-8628**