



**INSTALLATION INSTRUCTIONS**

**PLEASE** study these instructions carefully before beginning this installation. Most installations can be accomplished with common tools and procedures. However, you should be familiar with and comfortable working on your vehicle. If you do not feel comfortable performing this installation, it is recommended to have the installation completed by a qualified mechanic. If you have any questions, please call our **Technical Hotline at: 1-800-416-8628**, 7:00 am - 5:00 pm, Pacific Standard Time, Monday through Friday or e-mail us at [edelbrock@edelbrock.com](mailto:edelbrock@edelbrock.com).

**CAUTION:**

Installation of this product should be performed by persons knowledgeable in the repair and modification of automotive fuel systems. **Do not loosen fuel system connections until relieving fuel pressure** as recommended in your automotive service manual. Fuel leakage will occur when loosening fuel system connections, eliminate potential fire hazards before loosening any fuel system connections.

**DESCRIPTION:** Manufactured by Essex Industries, one of the most renowned fuel system manufacturers, Quiet-Flo™ Electric Fuel Pumps feature anodized aluminum housings and high quality internals resulting in quiet operation and long life. They are designed for use in universal carbureted applications such as street rods and muscle cars. Both pumps feature replaceable screen type inlet filters (**NOTE: Use of an in-line fuel filter in your fuel system is also recommended**). Mounting bracket and hardware are included.

- **1791:** Features a 3/8" NPT inlet and 3/8" NPT outlet. 1791 has a free flow rate of 120 gallons per hour, flows 48 gallons per hour at 5.0 psi, and will support up to 600 horsepower. Fuel pressure is externally adjustable from 5 to 10 psi and is factory preset to 6.5 psi. A fuel pressure regulator is not required when using the factory preset 6.5 psi fuel pressure.
- **1792:** Features a 1/2" NPT inlet and 1/2" NPT outlet. 1792 has a free flow rate of 160 gallons per hour, flows 80 gallons per hour at 6.5 psi, and will support up to 1000 horsepower. Fuel pressure is factory preset to 12 psi. An external fuel pressure regulator such as Edelbrock #1727 is required.

**INSTALLATION**

**NOTE:** Refer to the photos below throughout the installation. Continued instructions are on the next page.

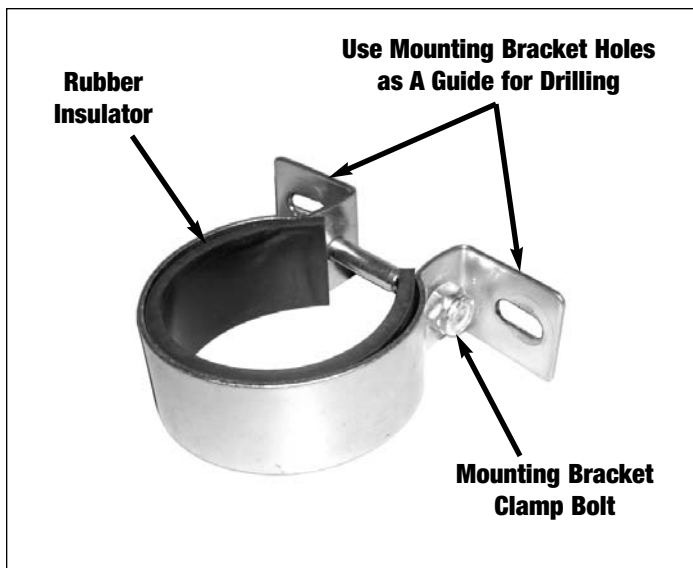

**Figure 1 - Fuel Pump Mounting Bracket**

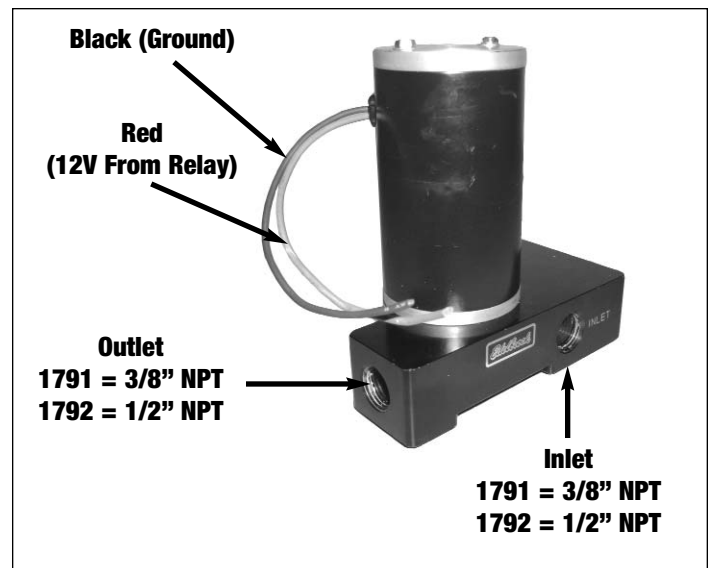

**Figure 2 - Fuel Pump**

## INSTALLATION

1. With the ignition off and engine cool, relieve the fuel system pressure.
2. Remove the fuel line, carburetor side and fuel tank side side of fuel pump.
3. Determine the new fuel pump mounting location.

**NOTE:** These pumps are only designed to push fuel from the rear of the vehicle forward, towards the engine bay. The pump must be mounted below the fuel level or pickup tube inlet for the pump to prime properly on startup. Ideal installation would mount the pump upright as shown in **Figure 2**, but the pump will operate in any orientation.

4. Replace existing fuel lines as necessary for proper fitment. Mark and drill mounting bracket holes using the bracket as a template (**See Figure 1**).
5. Assemble the bracket and fuel pump.
6. Install the fuel pump and bracket assembly in the desired location.
7. Install the appropriate fittings or use appropriate sized hose ends on your fuel line (**Fuel fittings not included**) (**See Figure 2**). Coat the threads of the fittings with thread sealer before assembly. Pump #1791 features 3/8" NPT inlet and outlet and 1792 features 1/2" NPT threads. See the Russell catalog or visit [www.russellperformance.com](http://www.russellperformance.com) for a selection of fittings and hose ends.

### 8. FUEL PUMP WIRING:

**NOTE:** Use of a 30 AMP relay is required. Edelbrock Universal Fuel Pump Relay #1795 is recommended.

Connect the **BLACK** wire to a battery ground or good engine/chassis ground, and the **RED** wire to the 12v output from the relay being used (**See Figure 2**). The relay should be wired such that power to the fuel pump is only on when the key is on. See the installation instructions to Universal Fuel Pump Relay #1795 for relay wiring instructions.

9. Connect and tighten fuel lines to the inlet and outlet. Then tighten mounting bracket clamp bolt (**See Figure 1**).
10. **Check for leaks:** Turn fuel pump on and check all connections for leaks. **If leaks exist**, immediately turn key off and repair before continuing.

## ADJUSTMENT

**NOTE:** Fuel pumps are preset to 6.5 psi (#1791) and 12 psi (#1792), which should be adequate in most situations. However, if you would like to adjust the fuel pump pressure, follow steps listed below:

1. Adjusting fuel pressure will require having a fuel pressure gauge installed between the fuel pump and carburetor. It is recommended to have a fuel pressure gauge installed in the fuel system to allow you to monitor your fuel pressure at all times. If you already have a pressure gauge installed, you may skip to step 4. If you do not have a gauge installed, make sure fuel pump is off, and pressure in the fuel line has been relieved before continuing.
2. Connect a fuel pressure gauge between the fuel pump and your carburetor.
3. Turn fuel pump on, however DO NOT start the engine. Make sure there are no leaks before continuing.
4. Start the engine and take a reading of the running fuel pressure. Locate the Adjustment screw (**See Fig. 3**) and adjust pressure to the desired level. Rotate the screw clockwise to increase fuel pressure or counter-clockwise to decrease fuel pressure.

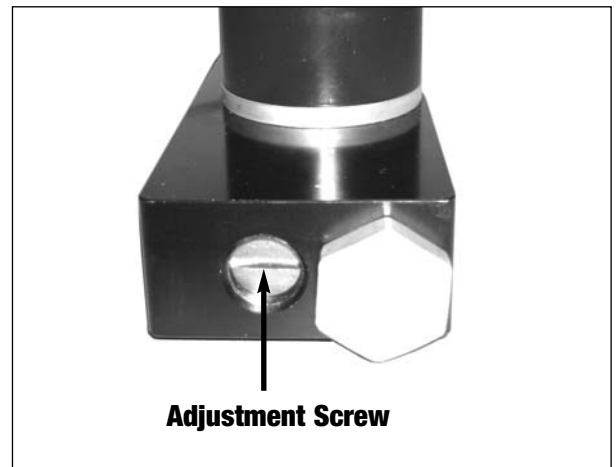

**Figure 3 - Fuel Pressure Adjustment**

5. If a pressure gauge was temporarily installed, turn off the pump and relieve the fuel pressure in the line. Remove the gauge and reconnect your fuel lines. Turn pump on and check for leaks before starting the engine.



**Edelbrock Corporation • 2700 California St. • Torrance, CA 90503**  
**Tech-Line: 800-416-8628 • E-Mail: Edelbrock@Edelbrock.com**