



# TORKER II MANIFOLD

CATALOG # 5076

MODEL: For Mopar 318\*-340-360 c.i.d.

## INSTALLATION INSTRUCTIONS

- **PLEASE** study these instructions, and the General Instructions, carefully before installing your new manifold. If you have any questions or problems, do not hesitate to contact our **Technical Hotline at: 1-800-416-8628**.
- **EGR SYSTEMS:** This manifold will not accept stock EGR (exhaust gas recirculation) equipment. EGR systems are used on some 1972 and later model vehicles and only in some states. Check local laws for requirements. Not legal for use in California on pollution-controlled vehicles.
- **MANIFOLD:** The Torker II manifold is designed for 318\*-340-360 c.i.d. V8 engines. Use the recommended electric or manual type choke carburetors only. This manifold is recommended for street performance and race vehicles only. The Torker II manifold is of single-plane design utilizing modern air flow technology. It provides good low rpm response for street performance vehicles plus increasing performance above the 5000 rpm range. It also provides horsepower and torque increases within the listed rpm range, when used with any mix of aftermarket equipment available for vehicles operating within that range.  
\*For maximum results, 318 c.i.d. engines should use 340-360 cylinder heads.
- **CARBURETOR RECOMMENDATIONS: CAUTION-**Use only carburetors recommended. If parts required for installation are unavailable locally, contact Edelbrock directly.

CARBURETOR	REFERENCE	PARTS REQUIRED FOR INSTALLATION
Performer #1407(750 cfm)	A, F, I, K, L, N, O	#1481-Throttle / Transmission Lever Kit

**Installation Notes:** Manifold height: A-5.250", B-6.187".

A-Carburetor will work with non-EGR (exhaust gas recirculation) or pre-emission control system.

F-Use carb-to-manifold base gasket same year & model as vehicle, unless base gasket supplied with carburetor.

I-Carburetor has no provision for evaporative canister.

K-Carburetor requires #8008 or #8024 stud, nut and washer kit. Determine length needed before installation.

L-Carburetor requires #8003, #8004 or #8022 Chrysler automatic transmission rod extension kit. Determine length needed before installation.

N-Carburetor acceptable to factory cruise control.

O-Carburetor has manual choke only.

### GASKETS AND SEALANT

**CAUTION-**Do not use high performance or competition type intake gaskets for street application. Due to material deterioration under street driving conditions, internal leakage of both vacuum and oil may occur.

1. Use only OE intake manifold gaskets or equivalent when installing Edelbrock manifolds for street applications.
  2. Apply Edelbrock Gasgacinch sealant , #9300, to both sides of the manifold as well as head surfaces. This procedure ensures a good seal.
  3. To eliminate end seal deterioration and slippage, we advise eliminating the end seals and using R.T.V. silicone. Apply a bead of sealant approximately 1/4" high across the block end seal surface, overlapping the intake gasket at the four corners. This procedure eliminates end seal problems.
- **MANIFOLD TORQUE** —Torque all bolts to 25 ft./lbs. See Figure #1 for proper sequence.  
**WARNING:** Marine engines that use salt water pump system will not work with automotive type manifolds. The OEM marine manifold uses a different water circulating system at the manifold outlet. Fresh water marine engines use a normal automotive manifold and are not affected by this problem. Valve covers may need to be trimmed at the intake runners to allow clearance for them to seat properly to heads. This will require removing valve covers from heads and trimming with suitable metal cutting snips.
  - **BRACKETS**—On vehicles with cruise control, bracket must be made to move the cruise control clamp. This ensures proper clamping of control cable. See Figure #2.
  - **DOWEL PIN REMOVAL** —Remove dowel pins from the front and rear valley gasket surfaces of engine block.
  - **PIPE PLUGS, FITTINGS AND BOLTS**—Install special bolt, included with manifold, in #8 bolt hole. See Figure #1

**TRANSMISSION LINKAGE CONVERSION 2-BBL TO 4-BBL**

**MOPARPARTS**

Year	Vehicle	Cable Bracket	Throttle Rod	Transmission Rod	Edelbrock Parts
1978-1982	2WD, 4WD, Vans	#357761	#3751553	#4115759	
1978-1982	Passenger Car with 3-piece Transmission Rod	#4027101	#4041548	no change	
1977	Vans only	no change	no change	no change	8022
1972-1976	2WD, 4WD	#3820191*	#2843776*	no change	8003, 8004
1972-1976	Vans only	no change	#3820654	#3820656	8003, 8004

- **CYLINDER NUMBERING AND FIRING ORDER**— For firing order and cylinder numbering, see Figure #3.
- **FINAL TUNING**
  1. NOTE: Local emission laws must be checked for legality of any carburetor or ignition changes.
  2. Minor changes may be made for final gain in performance and emissions changes.
  3. Due to the broad rpm range of this manifold, it is suggested that a basic ignition curve of 10° to 12° initial and a total of 32° to 34° advance be used and then be tailored to your vehicle's needs.
- **CAMSHAFT AND RELATED PARTS**—To get maximum performance with the Torker II manifold, we suggest using the Torker-Plus camshaft and matching components listed below:
  - Torker-Plus Camshaft / Lifters / Lube.....#5077
  - Sure Seat Valve Springs.....#5777
  - Performer-Link True-Rolling Timing Set .....#7803

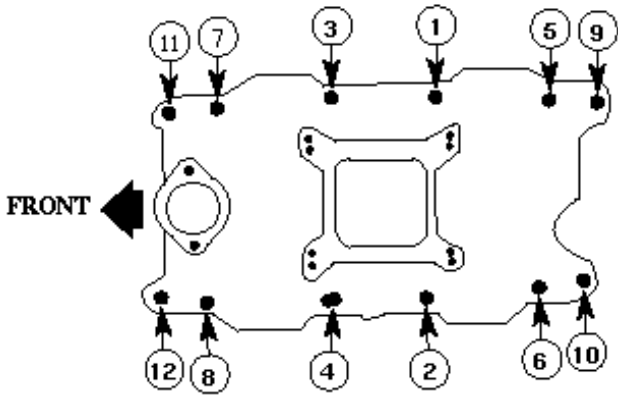

*Figure 1*  
**Intake Manifold Tightening Sequence**

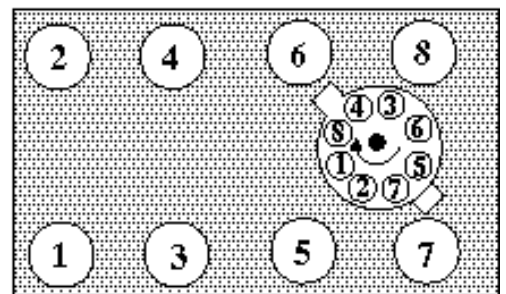
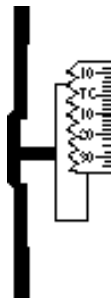

*Figure 3*  
**1-8-4-3-6-5-7-2**  
*Chrysler 318-340-36- c.i.d.*  
**Turn distributor counter-clockwise to advance timing**

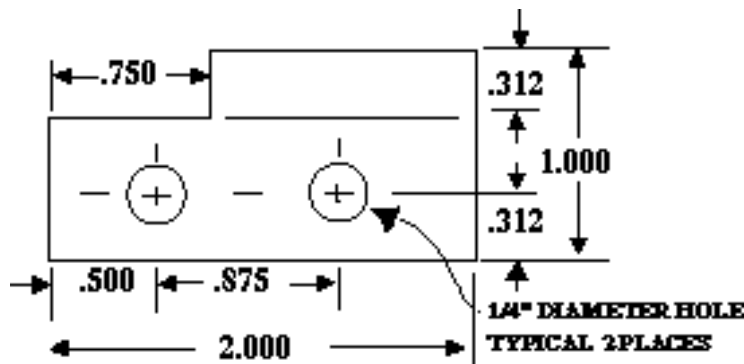

*Figure 2*