

# CONTROL ARM BUSHING INSTALLATION FOR SET # 3-3161



1131 VIA CALLEJON, SAN CLEMENTE, CA 92673

©2001 Energy Suspension. All rights reserved.  
May not be reproduced, in any form, or by any means,  
without the written consent of Energy Suspension.

## LOWER CONTROL ARM BUSHING INSTALLATION

For the ease of installation, disassemble the new bushing assembly. Install shells into both eyes of the control arm. Then stake shell in three places. (As shown in illustration on LEFT) For best results use a blunt instrument approx. 1/4" wide.

Re-grease I.D Of shells. Re-grease O.D and I.D of bushings. Reinstall bushing into one shell. Reinstall center sleeve. Install the cross shaft through opposite shell and through assembled bushing center sleeve. Install washer and nut on that end of cross shaft. Repeat bushing installation on the other bushing. It will be necessary to use a piece of tubing or a screwdriver to push center sleeve into bushing far enough to install the washer and start the nut on the cross shaft.

## UPPER CONTROL ARM BUSHING INSTALLATION

There are no tabs on the upper shells. Follow the same procedure as for the lower control arm bushing installation, with one exception. After one shell is installed, the cross shaft must be put into position, then install second shell. (Most upper shafts will not go through the empty shell)

**NOTE: TABS ON ORIGINAL SHELL MUST BE STRAIGHTENED BEFORE REMOVAL.**

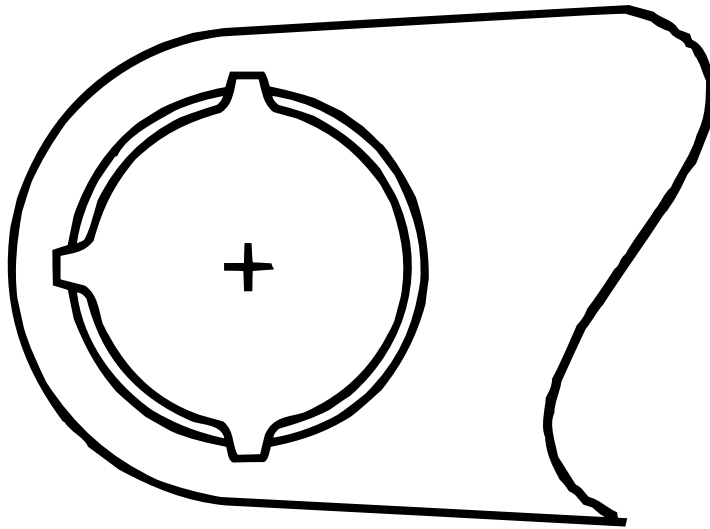

Check your control arm and make sure it is not bent. The arm should measure 16-15/16" minimum - 17" maximum. Outside edge to outside at inboard side.

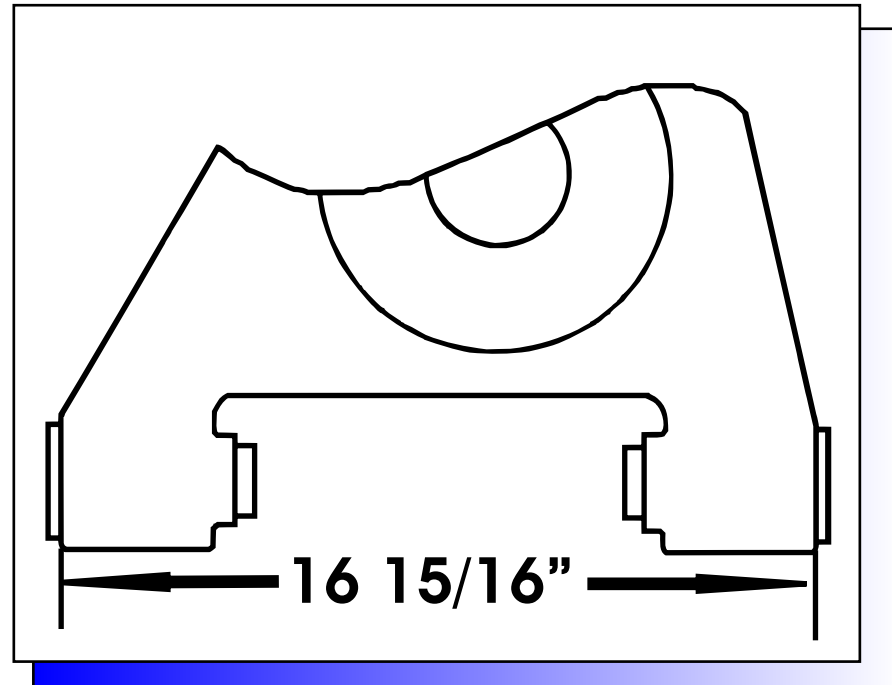

17111  
04/19/07 BPL