

Installation Instructions Set # 4-3156

Read all instructions prior to performing any work!



1131 VIA CALLEJON, SAN CLEMENTE, CA 92673

Support front of car securely on body.
Disconnect steering arm from spindle.
Remove lower spindle pinch bolt, separate lower control arm from spindle.
Remove front horizontal bushing position bolt.
Mark rear position bracket to ensure proper reinstallation.
Remove rear horizontal bushing bracket (2 bolts), remove lower control arm.
Press out front horizontal bushing, remove rear position horizontal bushing, see **NOTE**.
Remove any burrs on inside of control arm (front position) and on stud (rear position).
Thoroughly grease inside of control arm and stud. **NOTE:** direction of installation from diagram below.
Reinstall control arm.
IMPORTANT! Coat polyurethane bushing, sleeve and arm I.D. with supplied grease. (All surfaces of bushing that contact metal)

17316
3-13-00 NJT

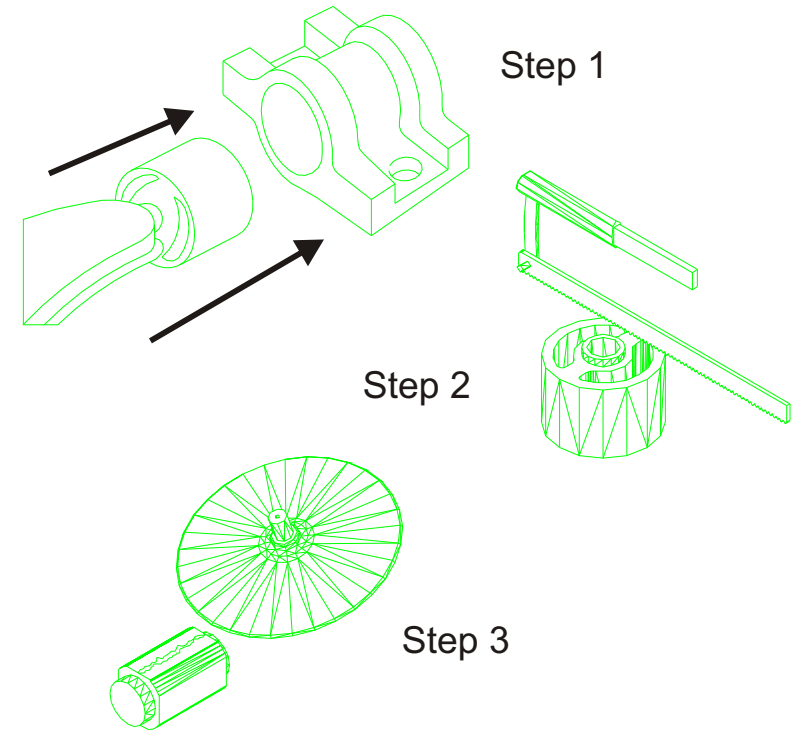
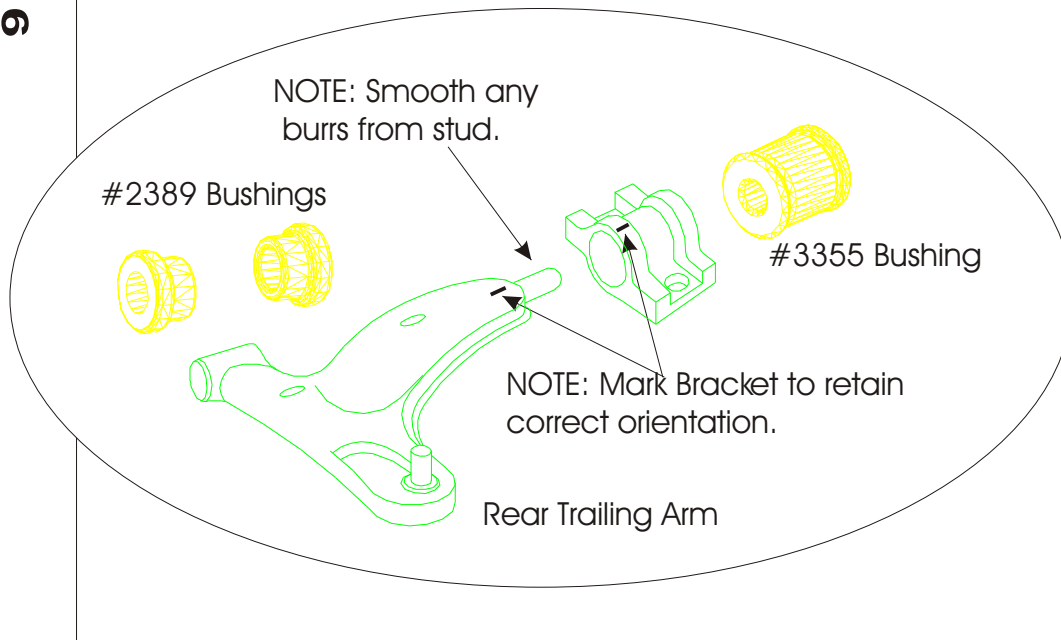

The below instructions are purely **SUGGESTIVE** and were found to be helpful. Use any means possible.

Step 1- Press rear position bracket off of bushing.

Step 2- To remove outer shell, use a hacksaw to cut two parallel incisions perpendicular to the reliefs in the rubber.

Step 3- **Using extreme caution and care!!!** Use a grinder and grind through rubber and the metal sleeve until there is a blue hue to the metal indicating that you have almost cut through the sleeve completely.

Step 4- Using a pair of pliers, rotate and remove the cut sleeve.

Step 5- Important! Remove and smooth any burrs from the metal stud.