



EARL'S EFI Fuel Kits PK0011ERL with 20 ft. Hose

1.0 FUEL SYSTEM INSTALLATION

DANGER! Take precautions to ensure all fuel components are away from heat sources, such as the engine or exhaust pipes. A fire or explosion hazard could cause serious injury or death!

DANGER! Before disconnecting or removing fuel lines, ensure the engine is cold. Do not smoke. Extinguish all open flames. An open flame, spark, or extreme heat near gasoline can result in a fire or explosion causing property damage, serious injury, and/or death.

DANGER! Never get under a vehicle supported only by a jack. Serious injury or death can result from vehicles falling off of jacks. Before working underneath a vehicle, support it solidly with jack stands.

1.1 Parts Identification

ITEM	DESCRIPTION	QTY	SERVICE PART
1	EFI Fuel Pump	1	2925
2	20 FT - 3/8 I.D. EFI Vapor Guard Hose	1 = 20 ft.	752066ERL (PK0011ERL)
3	Billet Vapor Guard Post Fuel Filter 10 micron	1	731166ERL
4	Billet Vapor Guard Pre Fuel Filter 100 micron	1	730066ERL
5	Vapor Guard Hose Clamp, Size 8	2	750006ERL
6	-6 ST. to 3/8 Vapor Guard Hose End	4	750166ERL
7	Fuel Cuff (240MM long)	1	12-719
8	Earl's PTFE Washers -6 pkg. of 2	1	177406ERL
9	-6 90 Deg. Bulkhead Fitting Black	1	AT983306ERL
10	-6 Bulkhead Nut Black	1	AT592406ERL



1



2



3



4



5



6



7



8



9



10

1.2 Fuel Pump and Filter Installation

The following section covers the installation of the in-line pump as well as the pre and post filters. **The fuel pump MUST be mounted lower than the lowest part of the fuel tank, and as close to the tank as possible. The fuel tank must also be properly vented.**

1. Use **Figure 1** below as a reference for the orientation and location of the fuel system components:

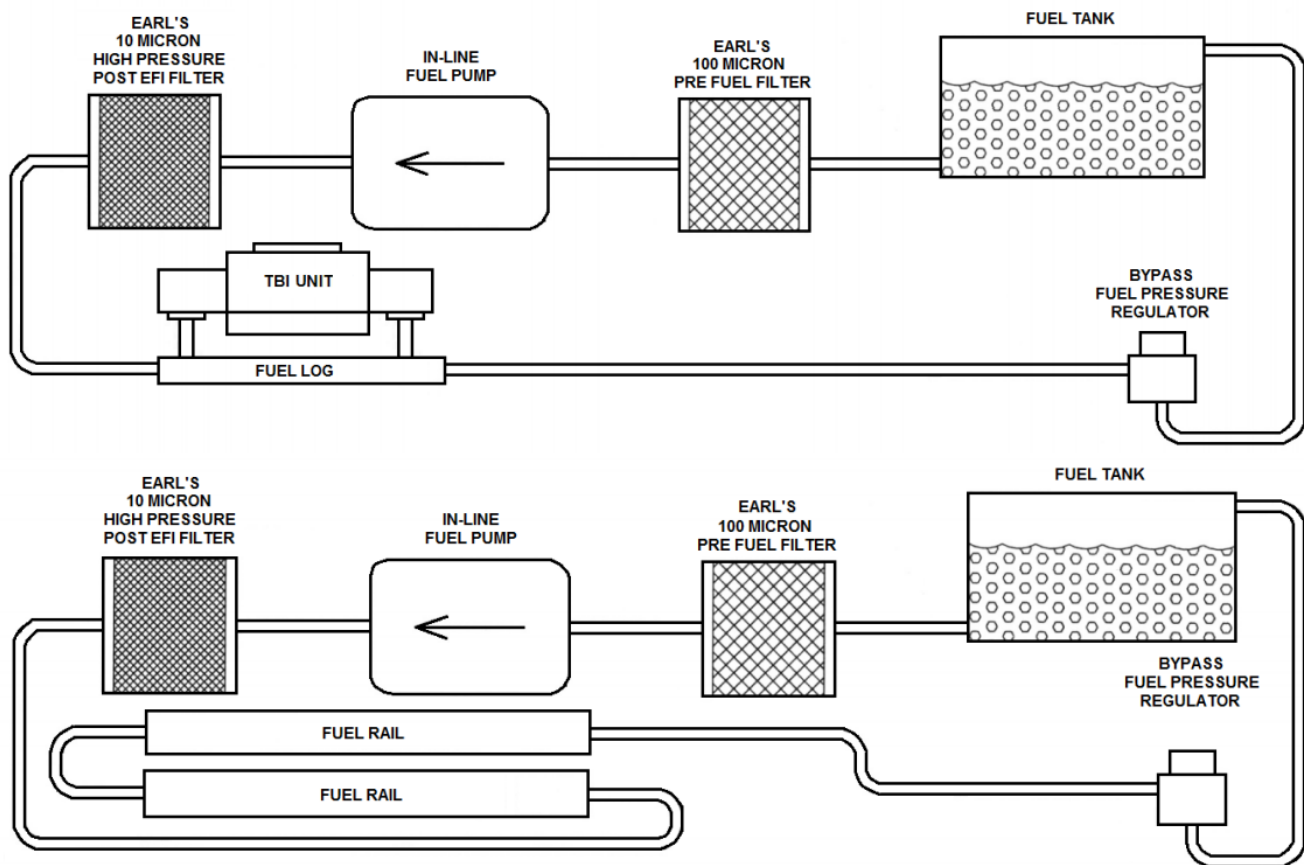

Figure 1

2. Mount the electric fuel pump as close to the fuel tank outlet as possible with the bracket provided. This will reduce fuel pump prime time, resulting in quick engine starts.
3. Two filters are included with this kit. The 100 micron pre-filter **MUST** be installed between the fuel tank and the fuel pump inlet (unless an in-tank pump is used in place of the pump in this kit). The purpose of this filter is to protect the fuel pump from particles of dirt or other foreign material. The filter should be installed with the arrow on the filter pointing in the direction of the fuel flow.
4. The post-fuel filter should be installed between the electric pump outlet and TBI unit/fuel rails. This is a 10 micron EFI filter. Position the filter, so the fuel hoses can be routed without kinks or sharp bends. The filter should be installed with the flow of the fuel going from in to out. (**Figure 2**).



Figure 2

WARNING! Ensure both filters are installed in the proper direction. A flow direction arrow is printed on the side of the filter to indicate the direction of fuel flow. Failure to do so will result in a system malfunction.

1.3 Return Line Bulkhead Fitting Installation

Some EFI systems requires a return fuel line to the fuel tank. PK0011ERL is intended to be used with an in-tank fuel module that has the return integrated into the module. PK0011ERL is also intended to be used with some late model vehicles which have a return line that can be utilized. The return line must not present a pressure restriction to the return fuel flow. There should never be more than approximately 3 PSI of pressure in the return line. A line that is too small, or has restrictions will cause tuning problems.

DANGER! Do not use the vapor canister lines as a fuel return line. Possible fuel leaks may create a fire or explosion hazard, causing serious injury or death.

DANGER! Proper installation of the fuel return line will necessitate complete removal of the fuel tank. This work should be done by a fuel tank specialist, who regularly does this work and is familiar with safety regulations and precautions necessary. If a person attempts this work, who is not familiar with the safety regulations and precautions, an explosion hazard may result causing serious injury or death.

1. Choose an ideal location for the bulkhead fitting to be installed. The fitting must be installed through a flat surface where the nut can be tightened from the bottom. It must also be installed in a location where the fuel cuff will not interfere with the sending unit float. If possible, we strongly recommend removing, cleaning, and drilling into the sending unit. The fitting must be oriented as shown below in **Figure 3**. The item numbers from section 1.1 are referenced.

DANGER! IF DRILLING INTO TANK (RATHER THAN SENDING UNIT), EARL'S RECOMMENDS HAVING YOUR TANK PROFESSIONALLY CLEANED BEFORE DRILLING. IF YOU CHOOSE NOT TO HAVE THE TANK PROFESSIONALLY CLEANED, DRAIN THE TANK COMPLETELY, LET DRY, AND FILL WITH WATER.

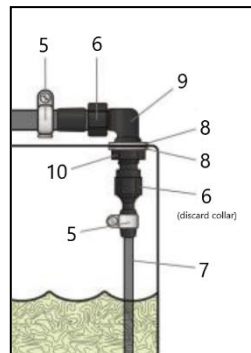

Figure 3

2. Drill a 9/16" hole and debur. Remove all metal shavings and particles from tank.
3. Install bulkhead fitting with one PTFE washer above the surface, and one below.
4. Screw bulkhead nut onto fitting from the bottom of the surface. Snug with a wrench. A spare bulkhead nut has been provided and will not be used in this installation.
5. Insert barbed end of a straight Vapor Guard hose end (**Item 6**) into an end of the fuel cuff (**Item 7**).
6. Slide hose clamp (**Item 5**) over fuel cuff and fitting and tighten to secure.
7. Screw fuel cuff assembly to bottom of bulkhead nut and snug with a wrench. Ensure bottom of cuff will be submerged in fuel as shown in **Figure 3**. Cuff can be trimmed if necessary.

1.4 Fuel Line Installation

With the fuel pump, filters, and bulkhead fitting all in place. You are now ready to install the fuel lines. Some connections will use hose clamps (**Item 5**), while others will use AN hose ends (**Item 6**). These connections are noted in **Figures 1 & 3**. Be sure to read and thoroughly understand all steps, notes, and hose assembly instructions (**Section 1.5**) below before proceeding with the fuel line installation.

DANGER! Failure to use a fuel hose that meets SAE J30 standards could result in fuel leaks. A fuel leak may result in a fire or explosion hazard, which could cause serious injury or death.

DANGER! Failure to use a steel fuel line that meets SAE J526 standards could result in fuel leaks. A fuel leak may result in a fire or explosion hazard, which could cause serious injury or death.

DANGER! Rigid fuel line tubing should be used for under vehicle runs, such as along vehicle frame rails or under floor pans. Failure to do so is a potential fire or explosion hazard, which could cause serious injury or death.

1. If using steel line, the hose (**Item 2**) can be used to connect the steel line to the pump and filters. You should not connect a rubber hose directly to a steel line unless the end of the line has a “bead/nipple” or barb that retains the hose. If the steel line is just cut off, purchase a compression fitting that a barbed hose end can be installed on, or use a tool to roll a bead/nipple on the end of the steel line.
2. If you plan to install a fuel pressure gauge, do so at this time. The Earl’s EFI fuel systems are designed for an operating pressure of up to 100 PSI.
3. If using the existing fuel lines, inspect and replace any hose, clamps, or fuel line showing **ANY** sign of aging. Anchor all fuel lines securely to solid chassis members at 1 ½ foot intervals using rubber coated steel clamps (not supplied). Use of only approved steel fuel line tubing will afford maximum fuel line protection against road hazards and premature wearing due to flexing, temperature extremes, road salt, weather, etc.

1.5 Hose Assembly

1. Cut the hose square with a sharp knife.
2. Lubricate the inside of the hose and the outside of the nipple. Use assembly lube or engine oil. Do not use a silicon-based lube.
3. Push the hose end into the hose until it bottoms.
4. Install the clamp and tighten.
5. Blow the assembly clean and pressure test before running the car.

Diagram

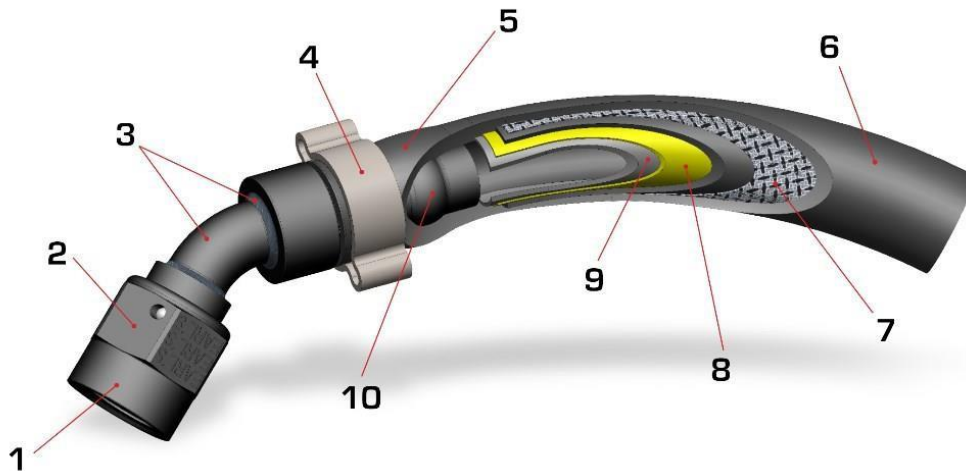

1. Black brite dip anodizing offers long-life even when used with today's harsh fuels
2. AN,SAE port & NPT hose ends available
3. Brazed bent-tube assembly provides unsurpassed strength
4. Three styles of stainless steel clamps available
5. Hose ends are adjustable in orientation after assembly for final clocking during installation
6. Exterior Cover - Extreme tolerance of heat and ozone
7. Reinforcement Braid - Aramid material (EFI hose only) is used to provide the high pressure rating that fuel injection requires
8. Vapor Guard Barrier - Thermoplastic layer provides superior fuel isolation virtually eliminating vapors from escaping through the hose
9. Primary Barrier Liner - Initial layer offers high resistance to heat and aggressive fuels
10. Vapor-Guard Retention Bead - retains hose under pressure while assuring hose liner is not damaged

Figure 4

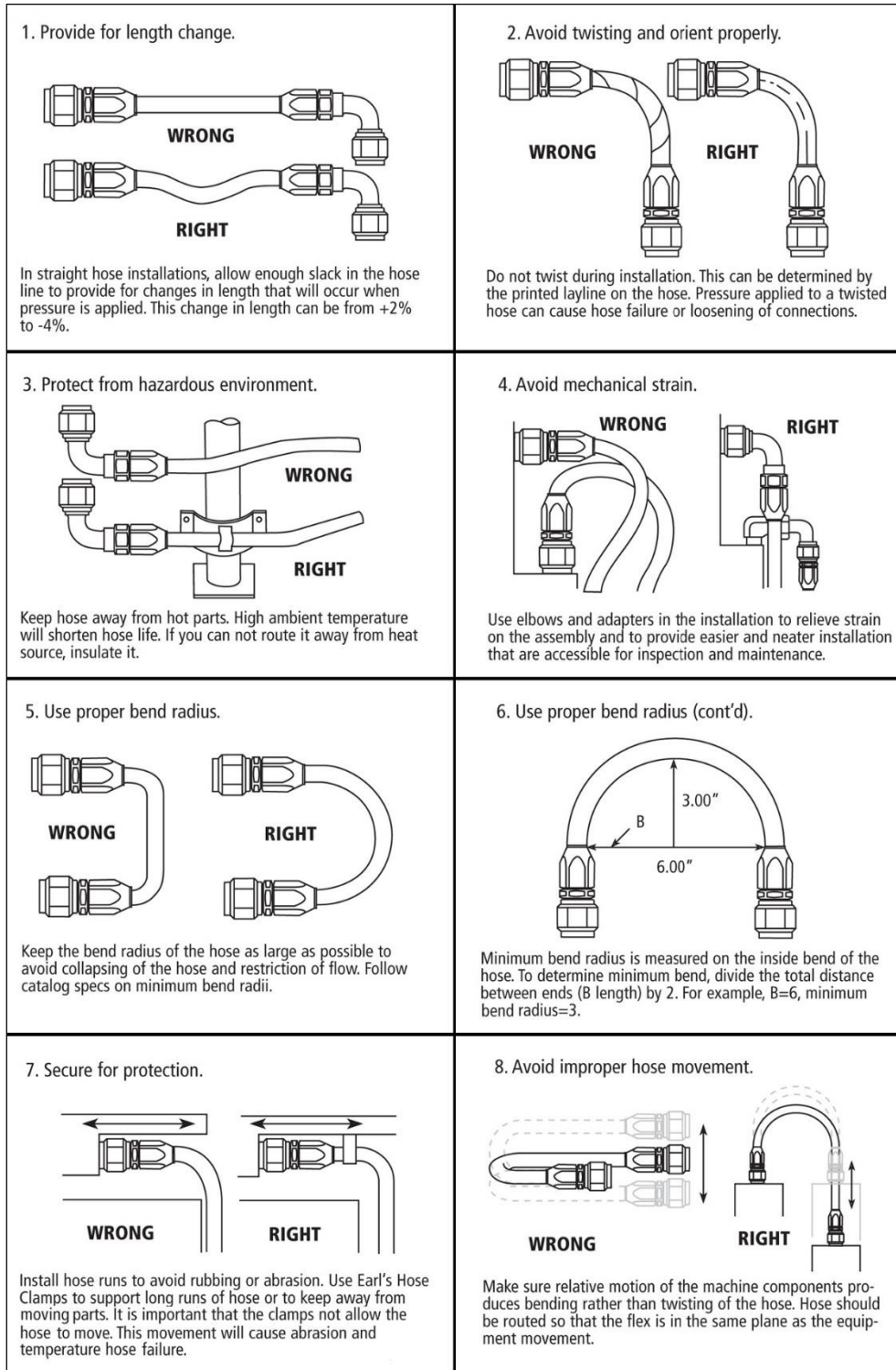

Figure 5

Holley Technical Support: 1-866-464-6553

© 2016 Holley Performance Products, Inc. All Rights Reserved. Tous Droits Réservés.

199R11930

Revision Date: 2-10-20