

! WARNING

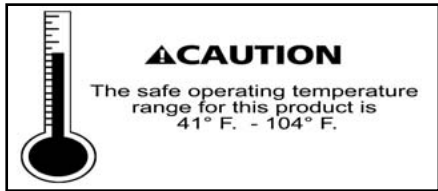

PLEASE READ THE ENTIRE CONTENTS OF THIS MANUAL PRIOR TO INSTALLATION AND OPERATION. BY PROCEEDING YOU AGREE THAT YOU FULLY UNDERSTAND AND COMPREHEND THE FULL CONTENTS OF THIS MANUAL. FORWARD THIS MANUAL TO ALL OPERATORS. FAILURE TO OPERATE THIS EQUIPMENT AS DIRECTED MAY CAUSE INJURY OR DEATH.

REV E 06-21-10
p/n 5900337

INSTALLATION AND OPERATION MANUAL

**6,000 POUND CAPACITY
LOW RISE LIFT
MODELS:
LR-60
LR-60P**



Keep this operation manual near the machine at all times. Make sure that ALL USERS read this manual.

SHIPPING DAMAGE CLAIMS

When this equipment is shipped, title passes to the purchaser upon receipt from the carrier. Consequently, claims for the material damaged in shipment must be made by the purchaser against the transportation company at the time shipment is received.

BE SAFE

Your new lift was designed and built with safety in mind. However, your overall safety can be increased by proper training and thoughtful operation on the part of the operator. DO NOT operate or repair this equipment without reading this manual and the important safety instructions shown inside.



1645 Lemonwood Dr.
Santa Paula, CA. 93060, USA
Toll Free 1-800-253-2363
Tel: 1-805-933-9970
Fax: 1-805-933-9160
www.bendpak.com

6000 POUND CAPACITY LOW-RISE LIFT



This instruction manual has been prepared especially for you.
Your new lift is the product of over 35 years of continuous research, testing and development;
it is the most technically advanced lift on the market today.

READ THIS ENTIRE MANUAL BEFORE INSTALLATION & OPERATION BEGINS.

RECORD HERE THE LIFT AND
POWER UNIT INFORMATION WHICH IS
LOCATED ON THE SERIAL NUMBER
DATA PLATES ON THE LIFT AND
ON THE POWER UNIT

Power Unit Model # _____
Power Unit Date Of Mfg. _____
Power Unit Serial # _____

This information is required when
calling for parts or warranty issues.

		
1645 Lemonwood Dr, Santa Paula, CA 93060 USA Tel: 1-805-933-9970 Fax: 1-805-933-9160 www.bendpak.com		
Model No.	Lifting Capacity	Serial No.
Date of Mfg.	Power Unit No.	Voltage / Amperage

PRODUCT WARRANTY

BendPak Low Rise Lifts are covered under warranty for one year on equipment structure, to be free of defects in material and workmanship. Power units, hydraulic cylinders, and all other assembly components such as turnplates, slip plates, cables, chains, valves, switches etc. are covered under warranty for one year against defects in material or workmanship under normal use. BendPak Inc. shall repair or replace at their option for the warranty period those parts returned to the factory freight prepaid which prove upon inspection to be defective. BendPak Inc. will pay labor costs for the first 12 months only on parts returned as previously described.

The warranty does not extend to...

- ◆ defects caused by ordinary wear, abuse, misuse, shipping damage, improper installation, voltage or lack of required maintenance;
- ◆ damages resulting from purchaser's neglect or failure to operate products in accordance with instructions provided in the owner's manual(s) and/or other accompanying instructions supplied;
- ◆ normal wear items or service normally required to maintain the product in a safe operating condition;
- ◆ any component damaged in shipment;
- ◆ other items not listed but may be considered general wear parts;
- ◆ damage caused by rain, excessive humidity, corrosive environments or other contaminant's.

THESE WARRANTIES DO NOT EXTEND TO ANY COSMETIC DEFECT NOT INTERFERING WITH EQUIPMENT FUNCTIONALITY OR ANY INCIDENTAL, INDIRECT, OR CONSEQUENTIAL LOSS, DAMAGE, OR EXPENSE THAT MAY RESULT FROM ANY DEFECT, FAILURE, OR MALFUNCTION OF A BENDPAK INC. PRODUCT OR THE BREACH OR DELAY IN PERFORMANCE OF THE WARRANTY.

**WARRANTY IS NOT VALID UNLESS
WARRANTY CARD IS RETURNED.**

IMPORTANT NOTICE

Do not attempt to install this lift if you have never been trained on basic automotive lift installation procedures. Never attempt to lift components without proper lifting tools such as a forklift or cranes. Stay clear of any moving parts that can fall and cause injury. These instructions must be followed to insure proper installation and operation of your lift. Failure to comply with these instructions can result in serious bodily harm and void product warranty. Manufacturer will assume no liability for loss or damage of any kind, expressed or implied resulting from improper installation or use of this product.

PLEASE READ ENTIRE MANUAL PRIOR TO INSTALLATION.

DEFINITIONS OF HAZARD LEVELS

Identify the hazard levels used in this manual with the following definitions and signal words:



DANGER

Watch for this symbol: It Means: Immediate hazards which will result in severe personal injury or death.



WARNING

Watch for this symbol: It Means: Hazards or unsafe practices which could result in severe personal injury or death.



CAUTION

Watch for this symbol: It Means: Hazards or unsafe practices which may result in minor personal injury, product or property damage.

OWNER'S RESPONSIBILITY

To maintain the lift and user safety, the responsibility of the owner is to read and follow these instructions:

- ◆ Follow all installation and operation instructions.
- ◆ Make sure installation conforms to all applicable Local, State, and Federal Codes, Rules, and Regulations; such as State and Federal OSHA Regulations and Electrical Codes.
- ◆ Carefully check the lift for correct initial function.
- ◆ Read and follow the safety instructions. Keep them readily available for machine operators.
- ◆ Make certain all operators are properly trained, know how to safely and correctly operate the unit, and are properly supervised.
- ◆ Allow unit operation only with all parts in place and operating safely.
- ◆ Carefully inspect the unit on a regular basis and perform all maintenance as required.
- ◆ Service and maintain the unit only with authorized or approved replacement parts.
- ◆ Keep all instructions permanently with the unit and all decals on the unit clean and visible.

BEFORE YOU BEGIN

Receiving:

The shipment should be thoroughly inspected as soon as it is received. The signed bill of lading is acknowledgement by the carrier of receipt in good condition of shipment covered by your invoice. If any of the goods called for on this bill of lading are shorted or damaged, do not accept them until the carrier makes a notation on the freight bill of the shorted or damaged goods. Do this for your own protection.

NOTIFY THE CARRIER AT ONCE if any hidden loss or damage is discovered after receipt and request the carrier to make an inspection. If the carrier will not do so, prepare a signed statement to the effect that you have notified the carrier (on a specific date) and that the carrier has failed to comply with your request.

IT IS DIFFICULT TO COLLECT FOR LOSS OR DAMAGE AFTER YOU HAVE GIVEN THE CARRIER A CLEAR RECEIPT. File your claim with the carrier promptly. Support your claim with copies of the bill of lading, freight bill, invoice, and photographs, if available. Our willingness to assist in helping you process your claim does not make BendPak responsible for collection of claims or replacement of lost or damaged materials.

TABLE OF CONTENTS

Contents	Page No.
Warranty / Serial Number Information	2
Definitions of Hazard Levels	3
Owner's Responsibility	3
Before You Begin.	3
Installer / Operator Agreement / Protective Equipment	5
Introduction	6
Safety / Warning Instructions	6
Tools Required	7
Step 1 / Selecting Site	7
Step 2 / Floor Requirements	7
Concrete Specifications.	7
Assembly View / Specifications	8
Step 3 / Power Unit Set Up.	9
Step 4 / Layout	9
Step 5 / Connecting Hydraulic Fittings / Hoses	9
Step 6 / Wiring Power Unit	10
Step 7 / Anchoring Lift (LR-60)	11
Step 8 / Installing Wheel Assemblies (LR-60P)	11
Step 9 / Lift Start Up / Final Adjustments	12
Step 10 Bleeding	13
Step 11 / Operation/ Maintenance	14-23
Troubleshooting Guide	24-27
Maintenance Records	28-29
Optional Equipment	30
Installation Agreement	31

**INSTALLER / OPERATOR
PLEASE READ AND FULLY
UNDERSTAND.
BY PROCEEDING YOU AGREE TO
THE FOLLOWING.**

◆ I have visually inspected the site where the lift is to be installed and verified the concrete to be in good condition and free of cracks or other defects. I understand that installing a lift on cracked or defective concrete could cause lift failure resulting in personal injury or death.

◆ I understand that a level floor is required for proper installation and level lifting.

◆ I understand that I am responsible if my floor is of questionable slope and that I will be responsible for all charges related to pouring a new level concrete slab if required and any charges.

◆ I understand that the lifts are supplied with concrete fasteners meeting the criteria of the American National Standard "Automotive Lifts - Safety Requirements for Construction, Testing, and Validation" ANSI/ALI ALCTV-2006, and that I will be responsible for all charges related to any special regional structural and/or seismic anchoring requirements specified by any other agencies and/or codes such as the Uniform Building Code (UBC) and/or International Building Code (IBC).

◆ I will assume full responsibility for the concrete floor and condition thereof, now or later, where the above equipment model(s) are to be installed.

◆ I understand that Bendpak lifts are designed to be installed in indoor locations only. Failure to follow installation instructions may lead to serious personal injury or death to operator or bystander or damage to property or lift.



Failure to follow danger, warning, and caution instructions may lead to serious personal injury or death to operator or bystander or damage to property.



Please read entire manual prior to installation. Do not operate this machine until you read and understand all the dangers, warnings and cautions in this manual. For additional copies or further information, contact:

BendPak Inc. / Ranger Products

1645 Lemonwood Dr.

Santa Paula, CA. 93060

1-805-933-9970

www.bendpak.com

**INSTALLER / OPERATOR
PROTECTIVE EQUIPMENT**

Personal protective equipment helps makes installation and operation safer, however, does not take the place of safe operating practices. Always wear durable work clothing during any installation and/or service activity. Shop aprons or shop coats may also be worn, however loose fitting clothing should be avoided. Tight fitting leather gloves are recommended to protect technician hands when handling parts. Sturdy leather work shoes with steel toes and oil resistant soles should be used by all service personnel to help prevent injury during typical installation and operation activities.

Eye protection is essential during installation and operation activities. Safety glasses with side shields, goggles, or face shields are acceptable. Back belts provide support during lifting activities and are also helpful in providing worker protection. Consideration should also be given to the use of hearing protection if service activity is performed in an enclosed area, or if noise levels are high.



THIS SYMBOL POINTS OUT IMPORTANT SAFETY INSTRUCTIONS WHICH IF NOT FOLLOWED COULD ENDANGER THE PERSONAL SAFETY AND/OR PROPERTY OR YOURSELF AND OTHERS AND CAN CAUSE PERSONAL INJURY OR DEATH. READ AND FOLLOW ALL INSTRUCTIONS IN THIS MANUAL BEFORE ATTEMPTING TO OPERATE THIS MACHINE.

INTRODUCTION

1. Carefully remove the crating and packing materials. **CAUTION!** Be careful when cutting steel banding material as items may become loose and fall causing personal harm or injury.

2. Check the voltage, phase and proper amperage requirements for the motor shown on the motor plate. Wiring should be performed by a certified electrician only.

IMPORTANT SAFETY INSTRUCTIONS!

Read these safety instructions entirely!

IMPORTANT NOTICE !

Do not attempt to install this lift if you have never been trained on basic automotive lift installation procedures. Never attempt to lift components without proper lifting tools such as forklift or cranes. Stay clear of any moving parts that can fall and cause injury.

1. **READ AND UNDERSTAND** all safety warning procedures before operating lift.

2. **KEEP HANDS AND FEET CLEAR.** Remove hands and feet from any moving parts. Keep feet clear of lift when lowering. Avoid pinch points.

3. **KEEP WORK AREA CLEAN.** Cluttered work areas invite injuries.

4. Consider work area environment. Do not expose equipment to rain. **DO NOT** use in damp or wet locations. Keep area well lighted.

5. **ONLY TRAINED OPERATORS** should operate this lift. All non-trained personnel should be kept away from work area. Never let non-trained personnel come in contact with, or operate lift.

6. **USE LIFT CORRECTLY.** Use lift in the proper manner. Never use lifting adapters other than what is approved by the manufacturer.

7. **DO NOT** override self-closing lift controls.

8. **REMAIN CLEAR** of lift when raising or lowering vehicle.

9. **CLEAR AREA** if vehicle is in danger of falling.

10. **ALWAYS INSURE** that the safeties are engaged before any attempt is made to work on or near vehicle.

11. **DRESS PROPERLY.** Non-skid steel-toe footwear is recommended when operating lift.

12. **GUARD AGAINST ELECTRIC SHOCK.** This lift must be grounded while in use to protect the operator from electric shock. Never connect the green power cord wire to a live terminal. This is for ground only.



13. **DANGER!** The power unit used on this lift contains high voltage. Disconnect power at the receptacle before performing any electrical repairs. Secure plug so that it cannot be accidentally plugged in during service.



14. **WARNING! RISK OF EXPLOSION.** This equipment has internal arcing or sparking parts which should not be exposed to flammable vapors. This machine should not be located in a recessed area or below floor level.



15. **MAINTAIN WITH CARE.** Keep lift clean for better and safer performance. Follow manual for proper lubrication and maintenance instructions. Keep control handles and/or buttons dry, clean and free from grease and oil.

16. **STAY ALERT.** Watch what you are doing. Use common sense. Be aware.

17. **CHECK FOR DAMAGED PARTS.** Check for alignment of moving parts, breakage of parts or any condition that may affect its operation. Do not use lift if any component is broken or damaged.

18. **NEVER** remove safety related components from the lift. Do not use lift if safety related components are damaged or missing.

TOOLS REQUIRED

- ◆ Rotary Hammer Drill Or Similar *
- ◆ 3/4" Masonry Bit *
- ◆ 1-1/4" Masonry Bit *
- ◆ Hammer *
- ◆ Wrenches:SAE/ Metric*
- ◆ Medium Crescent Wrench

- ◆ Crow Bar For Shim Installation*
- ◆ Lifting Blocks / Stands*
- ◆ Hydraulic Jack / Lifting Device*
- ◆ Medium Screwdriver
- ◆ Tape Measure

* Required for LR-60

IMPORTANT NOTICE!

These instructions must be followed to insure proper installation and operation of your lift. Failure to comply with these instructions can result in serious bodily harm and void product warranty. Manufacturer will assume no liability for loss or damage of any kind, expressed or implied resulting from improper installation or use of this product.

PLEASE READ ENTIRE MANUAL PRIOR TO INSTALLATION!

STEP 1

(Selecting Site)

Before installing your new lift, check the following:

1. **LIFT LOCATION:** Always use architects plans when available. Check layout dimension against floor plan requirements making sure that adequate space is available.
2. **OVERHEAD OBSTRUCTIONS:** The area where the lift will be located should be free of overhead obstructions such as heaters, building supports, electrical lines etc.
3. **DEFECTIVE FLOOR:** Visually inspect the site where the lift is to be installed and check for cracked or defective concrete.



4. **OPERATING TEMPERATURE.** Operate lift only between temperatures of 41° -104° F.

5. Lift is designed for **INDOOR INSTALLATION ONLY**

STEP 2

(Floor Requirements)



This lift must be installed on a solid level concrete floor with no more than 3-degrees of slope. Failure to do so could cause personal injury or death.

A level floor is suggested for proper use and installation and level lifting. If a floor is of questionable slope, consider a survey of the site and/or the possibility of pouring a new level concrete slab.



- ◆ **DO NOT** install or use this lift on any asphalt surface or any surface other than concrete.
- ◆ **DO NOT** install or use this lift on expansion seams or on cracked or defective concrete.
- ◆ **DO NOT** install or use this lift on a second / elevated floor without first consulting building architect.
- ◆ **DO NOT** install or use this lift outdoors.

CONCRETE SPECIFICATIONS

LIFT MODEL	CONCRETE REQUIREMENT
LR-60	3.5" Min Thickness / 2500PSI
LR-60P	3.5" Min Thickness / 2500PSI



DANGER!

All models **MUST** be installed on 2500 PSI concrete only conforming to the minimum requirements shown above. New concrete must be adequately cured by at least 28 days minimum.

IMPORTANT NOTE:

BendPak lifts are supplied with installation instructions and concrete fasteners meeting the criteria as prescribed by the American National Standard "Automotive Lifts - Safety Requirements for Construction, Testing, and Validation" ANSI/ALI ALCTV-2006. Lift buyers are responsible for any special regional structural and/or seismic anchoring requirements specified by any other agencies and/or codes such as the Uniform Building Code (UBC) and/or International Building Code (IBC).

⚠ DANGER

When removing the lift from packaging pay close attention as the lift can slide and can cause injury.

PARTS INVENTORY
Be sure to take a complete inventory of parts prior to beginning installation.

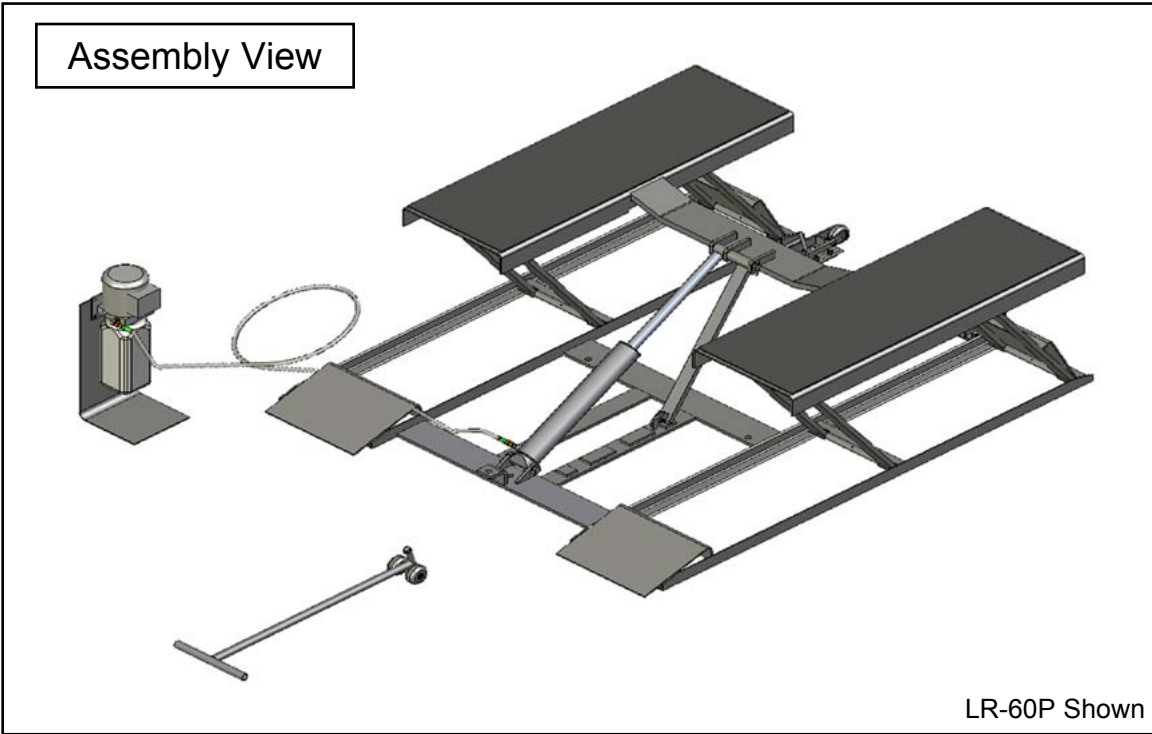

QTY	DESCRIPTION	PART #	CHECK
1	Main Frame Assembly	-----	
1	Hydraulic Power Unit	5585094	
1	Motor Stand	5700635	
4	Lifting Blocks 1 1/2"	5300845	
1	90° Fitting; 6801-04-06; (Power Unit)	5550103	
1	Straight Fitting 2404-04-04; (Cylinder)	5550147	
4	M8 x 1.25 x 20 Hex Head Bolts (Power Unit)	5530304	
4	M8 x 1.25 Hex Head Nuts (Power Unit)	5535356	
4	M8 Flat Washer (Power Unit)	5545340	
1	Hydraulic Hose Assy. (6.35 x 3640mm) DS 143"	5570863	
3	3/4" x 4" Wejit Anchors	5530455	
1	Tow handle (LR-60P Only)	5210863	
2	Wheel Assemblies (LR-60P Only)	5210907	

SPECIFICATIONS	LR-60	LR-60-P
Lifting Capacity	6,000 Lbs.	6,000 Lbs.
Lifting Height	26"	26"
Lifting Time	36 Seconds	36 Seconds
Frame Dimension	81-1/2" x 18"	81-1/2" x 18"
Lift Pad Dimensions	18" x 32"	18" x 32"
Lowered Height	4"	4"
Safety System	Mechanical Locks	Mechanical Locks
Hydraulic Power Unit	110/220 Volt / 60HZ / 1 Phase	110/220 Volt / 60HZ / 1 Phase
Fluid Capacity	1-1/2 Gallons	1-1/2 Gallons

STEP 3

(Power Unit Set Up)

1. Set the Power Unit on the Stand and mount using the four M8 bolts Nuts and Flat Washers.
(See Fig. 3.1)

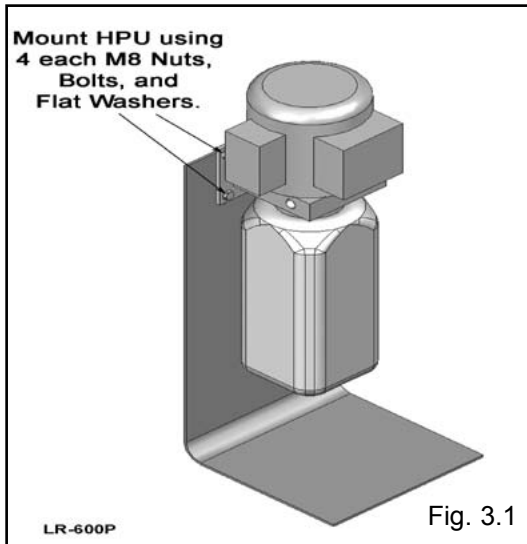

2. Fill the reservoir with 6 Quarts / 1.5 gals of Dexron III ATF or 10W Non-foaming hydraulic fluid.

STEP 4

(Layout)

1. Remember that the lift moves rearward approximately 14" when raised. (See Fig. 4.1)

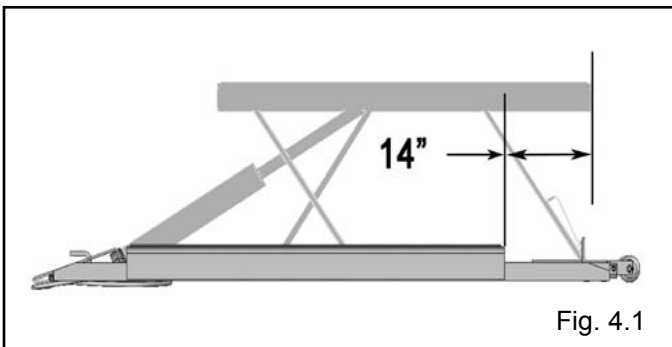

2. After selecting a site, place the unit in position making sure the Hydraulic Cylinder is placed towards the front of the bay. (Engine should be positioned at Cylinder side of lift.) (See Fig. 4.2)



3. Select a site for the Power Unit so that operators have a full, unobstructed view of the lift.

STEP 5

(Connecting Hydraulic Fittings / Hoses)

1. Remove the plastic plug from the left port of the Cylinder. (See Fig. 5.1)
2. Install the Straight Hydraulic Fitting in the left port of the Cylinder. Use Teflon Tape on the Cylinder side on the Fitting only. (See Fig. 5.1)

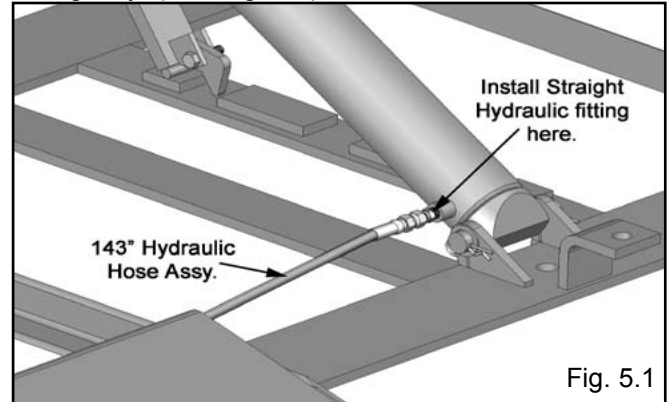

Connect one end of the 143" Hydraulic Hose Assy making sure to not over-tighten. Do not use Teflon Tape on this connection.

3. Install the 90-degree hydraulic Fitting in the pressure port of the Power Unit. The pressure port is covered with a plastic plug. (See Fig 5.2)

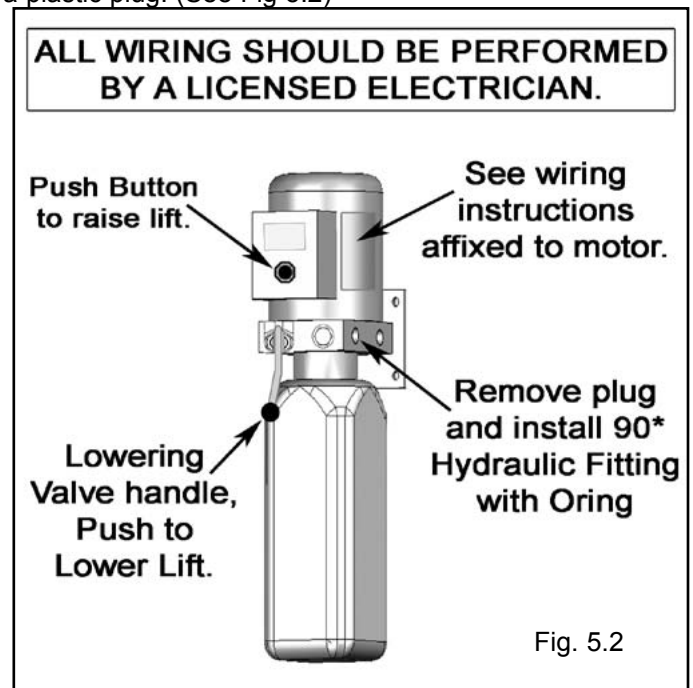

4. Connect the 143" Hydraulic Hose to the Power Unit fitting. Do not use Teflon Tape on this connection, make sure to not over-tighten.

STEP 6

(Wiring Power Unit)



DANGER !
ALL WIRING MUST BE PERFORMED
BY A LICENSED ELECTRICIAN.



DANGER!

DO NOT PERFORM ANY MAINTENANCE OR INSTALLATION OF ANY COMPONENTS WITH OUT FIRST ENSURING THAT ELECTRICAL POWER HAS BEEN DISCONNECTED AT THE SOURCE OR PANEL AND CANNOT BE RE-ENERGIZED UNTIL ALL MAINTENANCE AND/OR INSTALLATION PROCEDURES ARE COMPLETED.

1. Have a certified electrician verify the power supply to the power unit. Refer to the data plate found on the motor for proper power supply and wire size.

The standard power unit can be run on either 110V or 220V. It is already wired for 110V and equipped with a 3-wire power cord with grounding plug. For optional 220V hook up, follow the wiring instructions as shown on the motor data plate. See electrical data WARNING!



WARNING !

The power unit on this lift MUST NOT get wet. NEVER expose power unit to wet / damp conditions. Damage to power unit caused by moisture is not covered under warranty.



WARNING ! RISK OF EXPLOSION!

This equipment has internal arcing or parts that may spark and should not be exposed to flammable vapors. Motor should not be located in a recessed area or below floor level. NEVER expose motor to rain or other damp environments. DAMAGE TO MOTOR CAUSED BY WATER IS NOT COVERED UNDER WARRANTY.



- ◆ DO NOT run power unit with no oil. Damage to pump can occur.
- ◆ The power unit must be kept dry. Damage to power unit caused by water or other liquids such as detergents, acid etc., is not covered under warranty.
 - ◆ Operate lift only between temperatures of 41 °- 104° F.
- ◆ Improper electrical hook-up can damage motor and will not be covered under warranty.
 - ◆ Motor can not run on 50HZ without a physical change in motor.
 - ◆ Use a separate breaker for each power unit.
 - ◆ Protect each circuit with time delay fuse or circuit breaker.
 - ◆ For 110-120 volt, single phase, use a 20 amp fuse.
 - ◆ For 208-230 volt, single phase, use a 25 amp fuse.

STEP 7

(Anchoring Lift, LR-60 Only)

1. Before anchoring lift to the floor, confirm the location is satisfactory.
2. Using a 3/4" concrete bit, drill the floor using the holes on the frame as a guide. (See Fig. 7.1)
3. Remove all excess dust from holes, then install the anchor bolts. (See Fig. 7.1)
4. Tighten the anchor bolts to 25-30 ft.-lbs. using an open end wrench only. DO NOT use an impact wrench to tighten concrete anchors. (See Fig. 7.1)

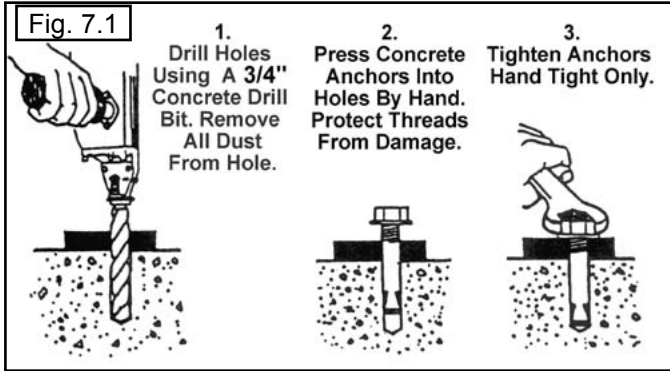

STEP 8

(Installing Wheel Assemblies)
(FOR LR-60-P ONLY)

1. Assemble the two Wheel Assemblies as shown in Fig 8.1 and 8.2.

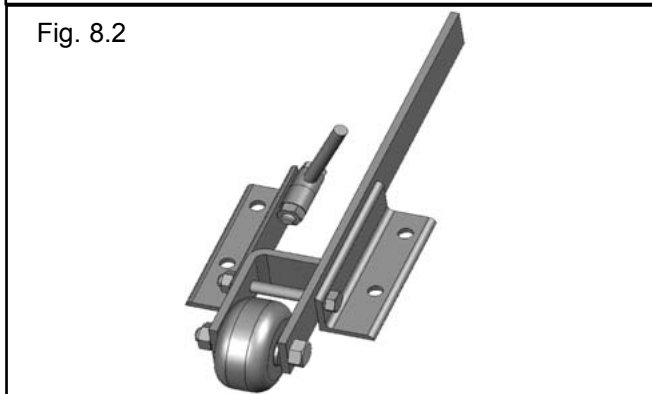
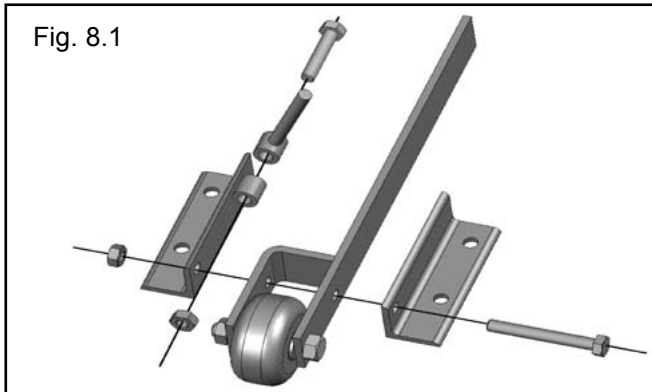

1. Using Hydraulic Jack or other lifting device, raise the lift off the Ground approximately 4- 6".



WARNING !
Place lift on blocks or stands **BEFORE** proceeding with any work under the lift.

2. Install the eight Flat Head Phillips Screws (four per side) up through the Flanges on the inside rails of the Lift. (See Fig. 8.3)

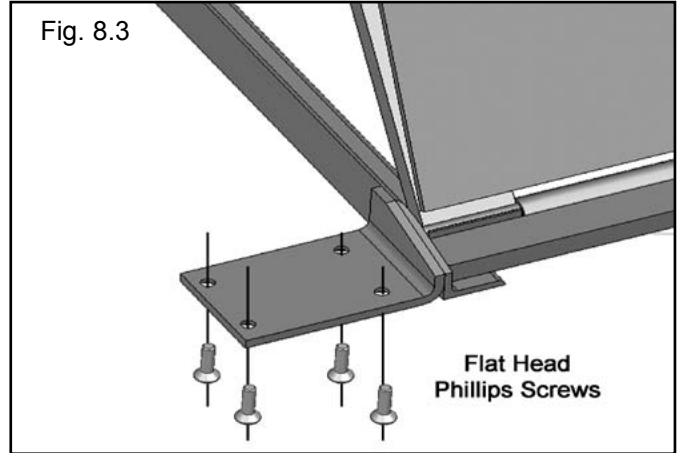

3. Install the Wheel Assemblies as shown. Install Split Lock Washers and tighten Hex Head Bolts. (See Fig. 8.4)

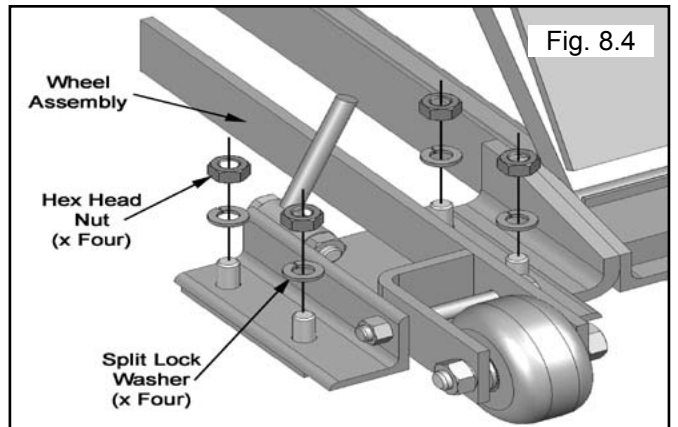

4. Remove any stands / blocks. Lower Lift back on the ground.



WARNING !
DO NOT OPERATE THE LIFT WITH THE WHEEL ASSEMBLIES IN THE DOWN POSITION.

TO MOVE LIFT

1. Pull up on Wheel Assembly handle.
2. Flip Down Wheel Pin. (See Fig. 8.5)

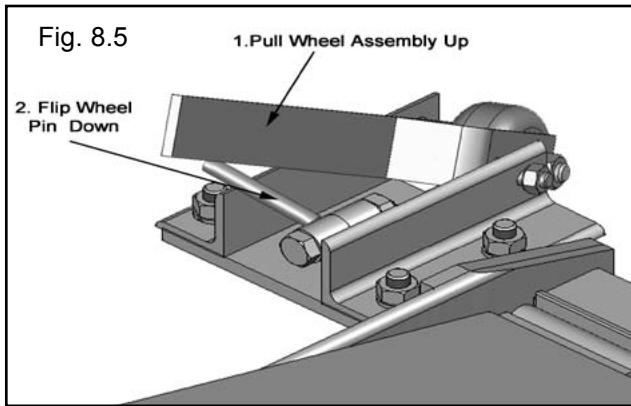

3. Insert the Tow Handle into the Tow Handle Anchor and push down on the Tow Handle to raise the Lift Assembly off the ground. (See Fig. 8.6)

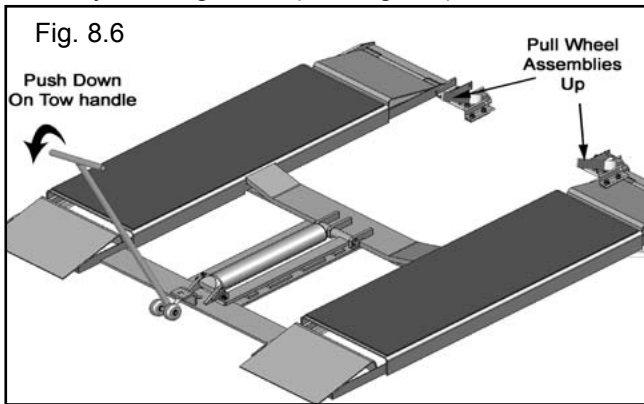

4. Remove the Tow Handle and Lower the Rear Wheel Assemblies.



WARNING !
DO NOT OPERATE THE LIFT WITH THE WHEEL ASSEMBLIES IN THE DOWN POSITION.

STEP 9

(Lift Start Up / Final Adjustments)



CAUTION!
During the START-UP procedure, observe all operating components and check for proper installation and adjustment. DO NOT attempt to raise vehicle until a thorough operational check has been completed.

1. Confirm the Power Unit reservoir is full with 6 quarts/ 1.5 gals of 10-WT hydraulic oil or Dexron-III automatic transmission fluid.

2. Test the Power Unit by pressing the push-button switch. If the motor sounds like it is operating properly, raise the lift and check all hose connections for leaks. If the motor gets hot or sounds peculiar, stop and check all electrical connections.



WARNING !
KEEP HANDS AND FEET CLEAR. Remove hands and feet from any moving parts. Keep feet clear of lift when lowering. Avoid pinch points.

ALWAYS WEAR SAFETY GOGGLES

3. Check the MAIN SAFETY LOCK to make sure it moves freely. Lubricate all SAFETY PIVOT points with WD-40 or equal.

4. **RAISE LIFT UNTIL THE CYLINDER BOTTOMS OUT AND THE LIFT STOPS.**

5. Lower the lift until the Safety rests In the Locked Position.

6. Verify that the Safety rests in the locked position at each safety stop. (See Fig. 9.1)

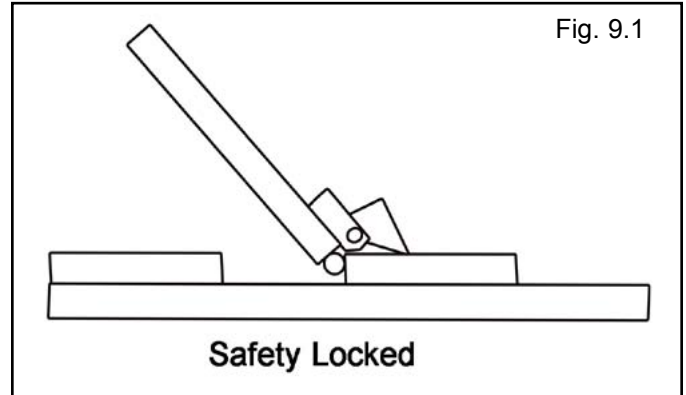

DANGER !
VISUALLY CONFIRM THAT ALL PRIMARY SAFETY LOCKS ARE ENGAGED BEFORE ENTERING WORK AREA.
Suspension components on this lift are intended to raise and lower lift only and are not meant to be load holding devices. Remain clear of elevated lift unless visual confirmation is made that all primary safety locks are fully engaged and the lift is LOWERED onto the safety locks, Refer to installation /operation manual for proper safety lock procedures and /or further instruction.

TO LOWER LIFT:

1. Raise the lift off the Safety locks by pressing the push button on the Power Unit. Make sure you raise the lift by at least two inches to allow adequate clearance for the Safety lock to clear. (See Fig. 9.2)

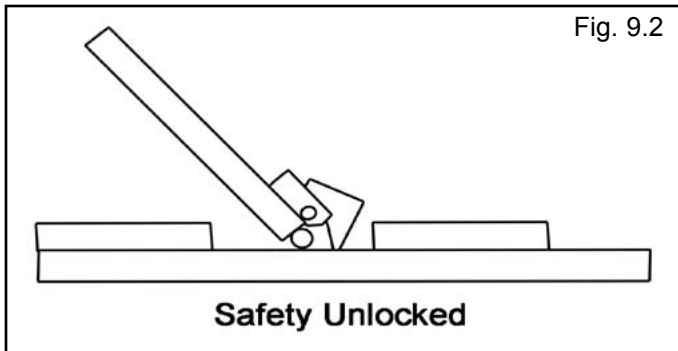

2. Lower lift by depressing lowering valve on Power Unit.

3. Run the lift up and down a few times to insure that the locks are engaging properly. Re-adjust or contact your installer or Bendpak if necessary

STEP 10

(Bleeding)

1. Lift must be fully lowered before changing or adding fluid.

2. Raise and lower lift six times. The Cylinder is self-bleeding. After bleeding system, fluid level in power unit reservoir may be down. Add more fluid if necessary to raise lift to full height. It is only necessary to add fluid to raise lift to full height.

3. To pressure test, run lift to full rise and run motor for approximately 3-seconds after lift stops. This will place pressure on the hydraulic system. Stop and check all fittings and hose connections. Tighten or reseal if required.

POST-INSTALLATION CHECK-OFF

- ◆ Lift Assembly, Level And Stable
- ◆ Electric Power Supply Confirmed
- ◆ Safety Locks Functioning Properly
- ◆ Check For Hydraulic Leaks
- ◆ Oil Level
- ◆ Lubrication of Critical Components
- ◆ Check For Overhead Obstructions
- ◆ Runways Level
- ◆ All Screws, Bolts, and Pins Secured
- ◆ Surrounding Area Clean
- ◆ Operation, Maintenance and Safety Manuals on Site

STEP 11

(Operation Instructions)

OWNER/EMPLOYER RESPONSIBILITIES

The Owner/Employer:

- Shall ensure that lift operators are qualified and that they are trained in the safe use and operation of the lift using the manufacturer's operating instructions; ALI/SM01-1, ALI Lifting it Right safety manual; ALI/ST-90 ALI Safety Tips card; ANSI/ALI ALOIM-2000, American National Standard for Automotive Lifts-Safety Requirements for Operation, Inspection and Maintenance; ALI/WL Series, ALI Uniform Warning Label Decals/Placards; and in the case of frame engaging lifts, ALI/LP-GUIDE, Vehicle Lifting Points/Quick Reference Guide for Frame Engaging Lifts.
- Shall establish procedures to periodically inspect the lift in accordance with the lift manufacturer's instructions or ANSI/ALI ALOIM-2000, American National Standard for Automotive Lifts-Safety Requirements for Operation, Inspection and Maintenance; and The Employer Shall ensure that lift inspectors are qualified and that they are adequately trained in the inspection of the lift.
- Shall establish procedures to periodically maintain the lift in accordance with the lift manufacturer's instructions or ANSI/ALI ALOIM-2000, American National Standard for Automotive Lifts-Safety Requirements for Operation, Inspection and Maintenance; and The Employer Shall ensure that lift maintenance personnel are qualified and that they are adequately trained in the maintenance of the lift.

- Shall maintain the periodic inspection and maintenance records recommended by the manufacturer or ANSI/ALI ALOIM-2000, American National Standard for Automotive Lifts-Safety Requirements for Operation, Inspection and Maintenance.

- Shall display the lift manufacturer's operating instructions; ALI/SM 93-1, ALI Lifting it Right safety manual; ALI/ST-90 ALI Safety Tips card; ANSI/ALI ALOIM-2000, American National Standard for Automotive Lifts-Safety Requirements for Operation, Inspection and Maintenance; and in the case of frame engaging lifts, ALI/LP-GUIDE, Vehicle Lifting Points/Quick Reference Guide for Frame Engaging Lifts; in a conspicuous location in the lift area convenient to the operator.

- Shall provide necessary lockout/tagout means for energy sources per ANSI Z244.1-1982 (R1993), Safety Requirements for the Lockout/Tagout of Energy Sources, before beginning any lift repairs.

- Shall not modify the lift in any manner without the prior written consent of the manufacturer.



LIFT OPERATION SAFETY

- **DAILY** inspect your lift. Never operate if it malfunctions or if it has broken or damaged parts. Use only qualified lift service personnel and genuine BendPak parts to make repairs.
- **THOROUGHLY** train all employees in use and care of lift, using manufacturer's instructions and "Lifting It Right" and "Safety Tips" supplied with the lift.
- **NEVER** allow unauthorized or untrained persons to position vehicle or operate lift.
- **PROHIBIT** unauthorized persons from being in shop area while lift is in use.
- **DO NOT** permit anyone on lift or inside vehicle when it is either being raised or lowered.
- **ALWAYS** keep area around lift free of tools, debris, grease and oil.
- **NEVER** overload lift. Capacity of lift is shown on nameplate affixed to the lift.
- **DO NOT** stand in front of the vehicle while it is being positioned in lift bay.
- **DO NOT** hit or run over lift arms or adapters. This could damage lift or vehicle. Before driving vehicle into lift bay, position arms and adapters to provide unobstructed entrance onto lift.
- **ALWAYS** load vehicle on lift carefully. Position the lift adapters to contact at the vehicle manufacturer's recommended lift points. Raise lift until adapters contact vehicle. Check adapters for secure contact with vehicle. Raise lift to desired working height. (See Fig.17.1)

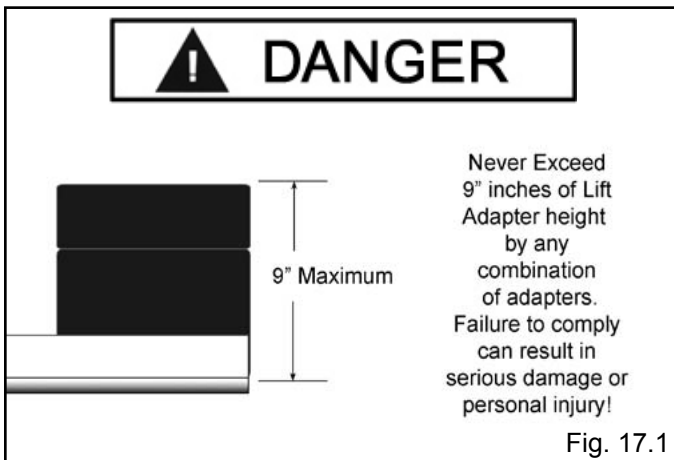

- **DO NOT** block open or override self-closing lift controls; they are designed to return to the "Off" or Neutral position when released.
- **DO NOT** remove or disable arm restraints.

- **ALWAYS** remain clear of lift when raising or lowering vehicles.
- **ALWAYS** use safety stands when removing or installing heavy components.
- **DO NOT** go under raised vehicle if safety locks are not engaged.



DANGER!
VISUALLY CONFIRM THAT ALL PRIMARY SAFETY LOCKS ARE ENGAGED BEFORE ENTERING WORK AREA.
Suspension components on this lift are intended to raise and lower lift only and are not meant to be load holding devices. Remain clear of elevated lift unless visual confirmation is made that all primary safety locks are fully engaged and the lift is LOWERED onto the safety locks, Refer to installation /operation manual for proper safety lock procedures and /or further instruction.

- **NEVER LEAVE LIFT IN ELEVATED CONDITION** unless all Safety Locks are engaged.
- **AVOID** excessive rocking of vehicle while on lift.
- **ALWAYS CLEAR AREA** if vehicle is in danger of falling.



When lowering the lift PAY CAREFUL ATTENTION that all personnel and objects are kept clear. ALWAYS keep a visual line of site on the lift AT ALL TIMES. ALWAYS make sure that ALL LOCKS are disengaged. If one of the locks inadvertently locks on descent the lift and/or vehicle may disrupt causing personal injury or death,

- **ALWAYS REMOVE** tool trays, stands, etc. before lowering lift.
- **ALWAYS RELEASE** safety locks before attempting to lower lift.
- **ALWAYS POSITION** the lift arms and adapters to provide an unobstructed exit before removing vehicle from lift area.

TO RAISE THE LIFT



WARNING!

To avoid personal injury and/or property damage, permit only trained personnel to operate lift. After reviewing these instructions, get familiar with lift controls by running the lift through a few cycles before loading vehicle on lift. Always lift the vehicle using all four adapters. **NEVER** raise just one end, one corner, or one side of vehicle.

1. Before Loading: Lift must be fully lowered and service bay clear of all personnel before the vehicle is brought on lift with the arms (if used) set to the full drive-thru position.
2. Loading: Position arms under vehicle and position adapters at vehicle manufacturer's recommended lift points. Use height extenders or optional frame-cradle adapters (if applicable) when necessary to ensure good contact. (See Fig 17.2-3)

Fig. 17.2

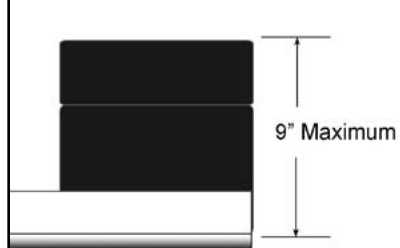
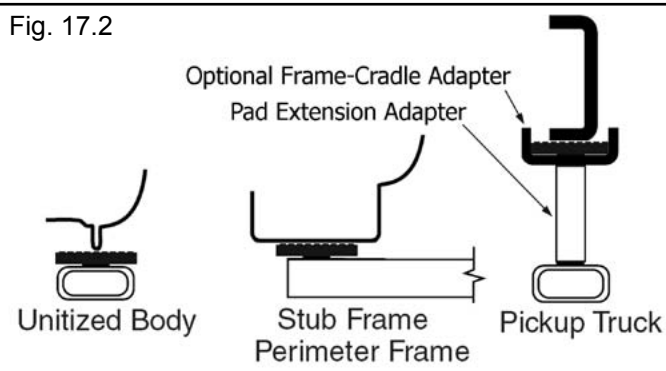

Never Exceed 9" inches of Lift Adapter height by any combination of adapters. Failure to comply can result in serious damage or personal injury!

Fig. 17.3

3. Some vehicles may have the manufacturer's Service Garage Lift Point locations identified by triangle shape marks on the undercarriage (reference ANSI/SAE J2184-1992). Also, there may be a label located on the right front door jamb area showing specific vehicle lift points.



WARNING!

Many specialty or modified vehicles cannot be raised on a two-post frame engaging lift. Contact vehicle manufacturer for raising or jacking details.

TYPICAL LIFTING POINTS

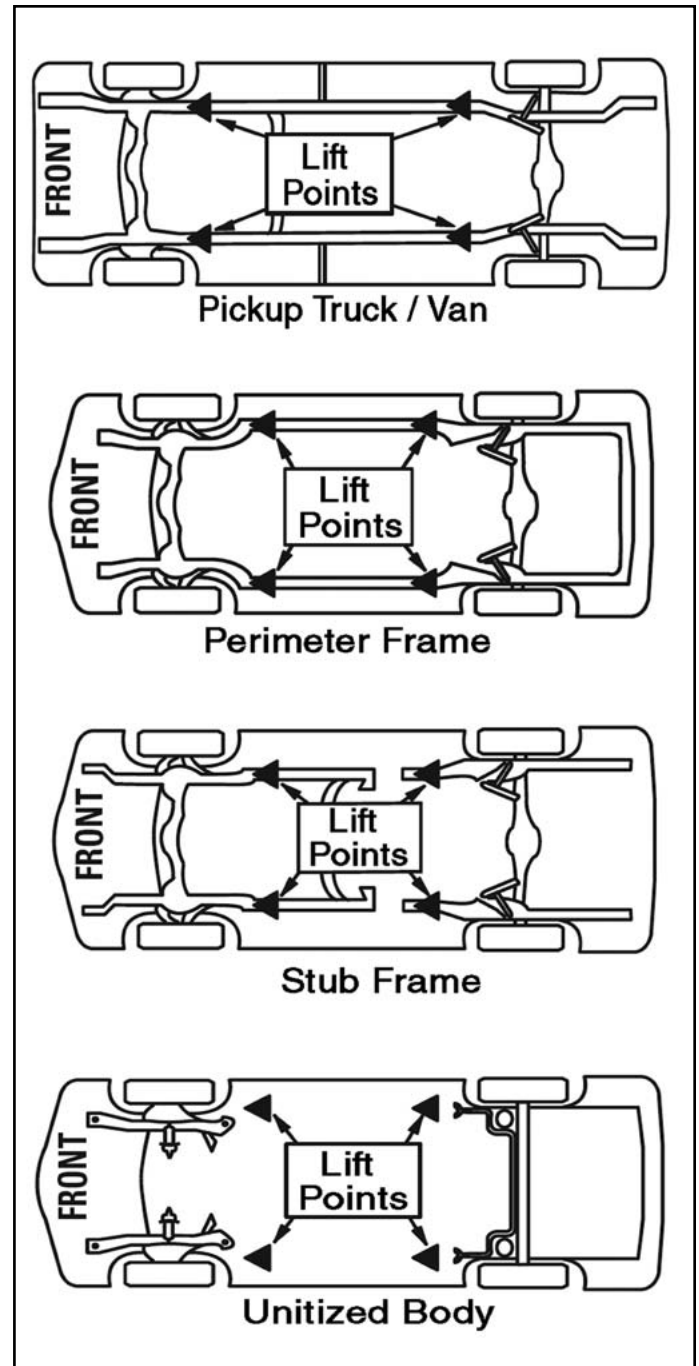

4. Position vehicle for proper weight distribution arms under vehicle to allow adapters /pads to contact at the manufacturer's recommended pick up points.

5. If the specific vehicle lift points are not identified, or if the vehicle has additional or uniquely positioned payload, have a qualified person calculate the vehicle center of gravity or have the vehicle center of gravity determined at a vehicle scale. Load the vehicle with the center of gravity midway between adapters.

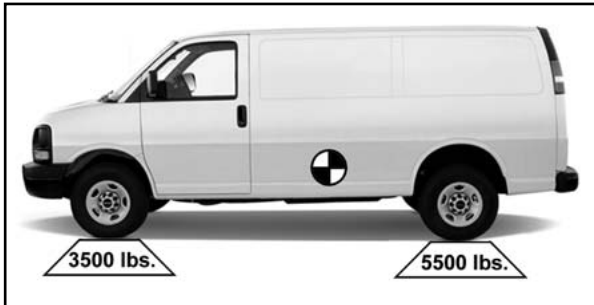

WARNING!

DO NOT Park wheels directly on lift pads.

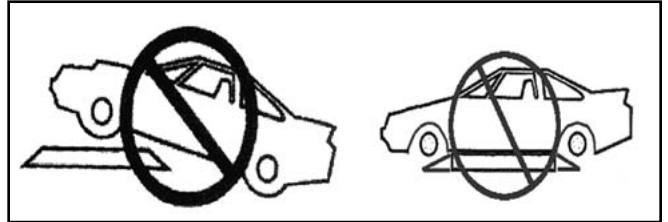

6. Set parking brake or use wheel chock to hold vehicle in position.



Make sure vehicle is neither front nor rear heavy and select the proper configuration for the vehicle to be lifted as shown below. Center of balance should be midway between adapters and centered over the lift.

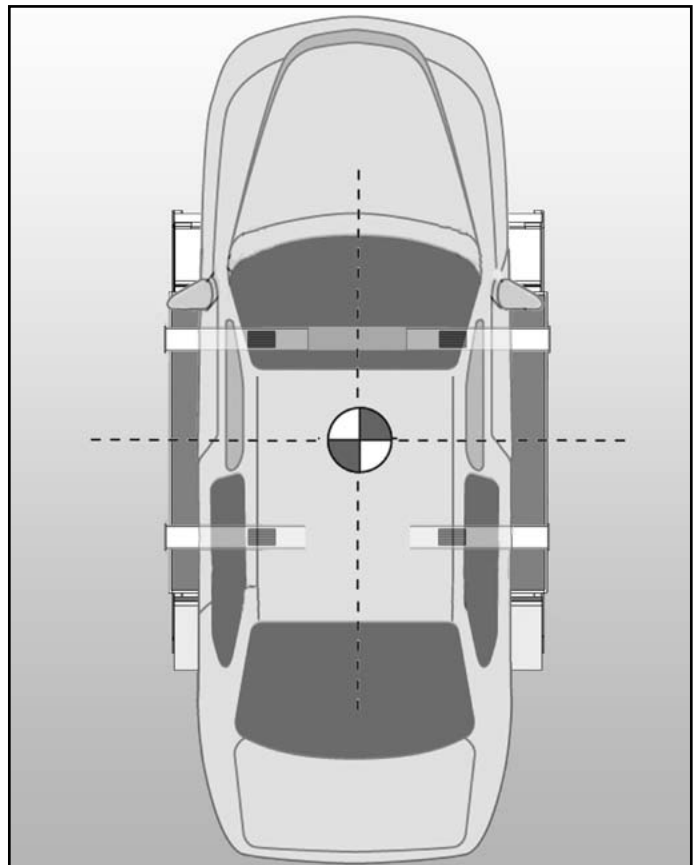
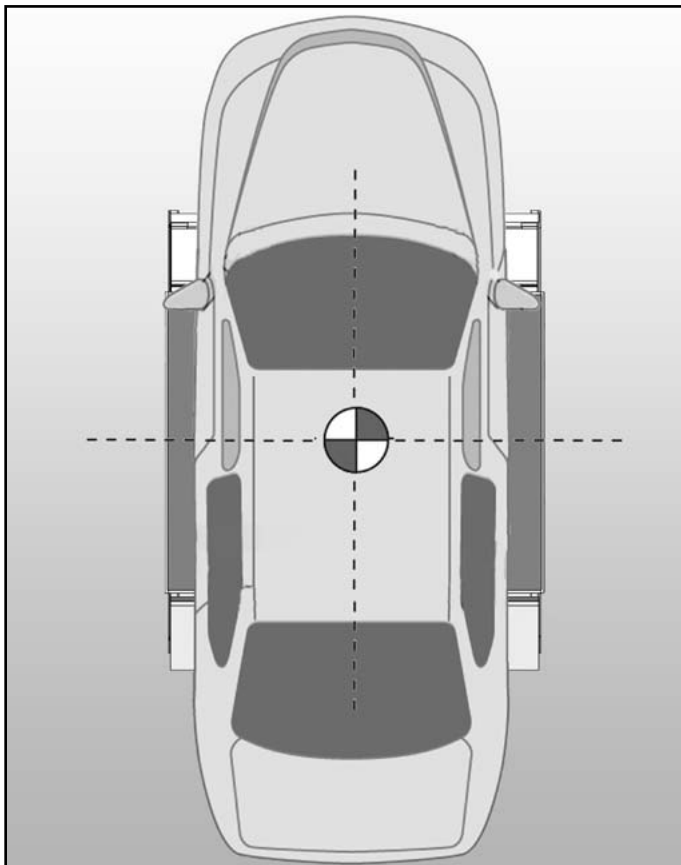

7. Push the **RAISE** button or rotate the control switch on the power unit.

Important Note:

**Allow (2) seconds between motor starts.
Failure to comply may cause motor burnout.**

8. Stop before making contact with vehicle. Check contact points. If required, slightly move arms or vehicle to allow restraint gear and pawl to mesh.

9. Raise vehicle until tires clear the floor.

10. Stop and check adapters for secure contact at vehicle manufacturer's recommended lift points.

11. Continue to raise to desired height only if vehicle is secure on lift.

12. **DO NOT** go near or under a raised vehicle if all four adapters are not in secure contact with vehicle at vehicle manufacturer's recommended lift points.

13. Repeat entire loading and raising procedures if required.

14. Lower lift onto safety locks.

• **DO NOT** enter work area or go under vehicle if safety locks are not engaged.



DANGER!
VISUALLY CONFIRM THAT ALL PRIMARY SAFETY LOCKS ARE ENGAGED BEFORE ENTERING WORK AREA.
Suspension components on this lift are intended to raise and lower lift only and are not meant to be load holding devices. Remain clear of elevated lift unless visual confirmation is made that all primary safety locks are fully engaged and the lift is **LOWERED** onto the safety locks, Refer to installation /operation manual for proper safety lock procedures and /or further instruction.

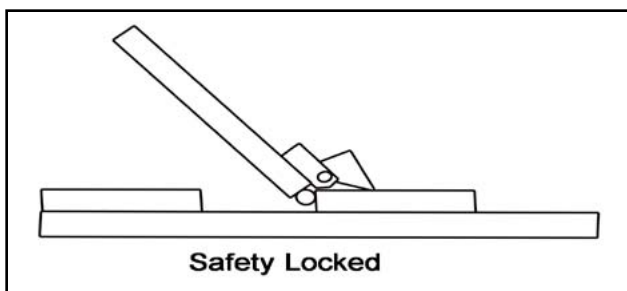

- **CLEAR AREA** if vehicle is in danger of falling.
- **DO NOT** position yourself between a wall and the lift. If the vehicle falls in that direction, you may be severely injured.
- Before attempting to lift pickup trucks or other truck frame vehicles, be sure that:
 - ◆ Vehicle frame is strong enough to support its weight and has not been weakened by modification or corrosion.
 - ◆ Vehicle individual axle weight does not exceed one-half lift capacity.
 - ◆ Adapters are in secure contact with frame at vehicle manufacturers recommended lift points.
 - ◆ Vehicle is stable on lift and neither front nor "tail" heavy.

WHILE USING LIFT

- Avoid excessive rocking of vehicle while on lift.
- Always use safety stands as needed or when removing or installing heavy components.

TO LOWER THE LIFT



WARNING!
When lowering the lift **PAY CAREFUL ATTENTION** that all personnel and objects are kept clear. **ALWAYS** keep a visual line of site on the lift **AT ALL TIMES. ALWAYS** make sure that **ALL LOCKS** are disengaged. If one of the locks inadvertently locks on descent the lift and/or vehicle may disrupt causing personal injury or death.

1. Remove all tools or other objects from the lift area.
2. Raise lift off safety locks. Make sure you raise the lift by at least two inches to allow adequate clearance for the locks to clear.
3. Confirm safety lock is in unlocked position.

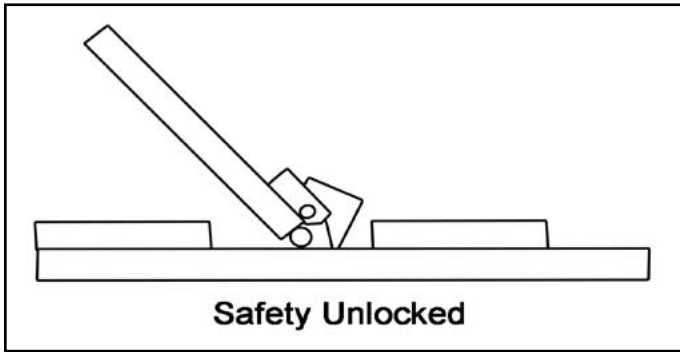

4. Push LOWERING valve handle to lower. Do not override self-closing lift controls.
5. Remain clear of lift when lowering vehicle. Observe pinch point warning decals.
6. Remove adapters from under vehicle and arms to full drive-thru position before moving vehicle.
7. If lift is not operating properly, Do Not use until adjustment or repairs are made by qualified lift service personnel.

MAINTENANCE INSTRUCTIONS



CAUTION!

If you are not completely familiar with automotive lift maintenance procedures; STOP: Contact factory for instructions. To avoid personal injury, permit only qualified personnel to perform maintenance on this equipment.

- Always keep bolts tight. Check periodically.
- Always keep lift components clean.
- Always if oil leakage is observed, call local service representative.
- Always if electrical problems develop, call local service representative.
- Always replace ALL FAULTY PARTS before lift is put back into operation.
- Daily: Make a visual inspection of ALL MOVING PARTS and check for excessive signs of wear.
- Daily: Check Safety Locks to insure they are in good operating condition.
- Daily: Check pivot points and hinges for wear. Replace worn parts as required with genuine BendPak parts.
- Daily: Inspect adapters for damage or excessive wear. Replace as required with genuine BendPak parts.
- Weekly: Lubricate any rollers with general purpose oil or WD-40. Lubricate arm Hinge Pins with grease.
- Weekly: Check bolts and pins to insure proper mounting.
- Monthly: Lubricate locking latch shafts. Push latch handle several times for oil to penetrate pivot points.
- Every 3 Months: Check anchor bolts for tightness. Anchors should be torqued to 90 ft/lbs.
- Semi-Annually: Check fluid level of lift power unit and refill if required per lift installation instructions.
- Replace all caution, warning or safety related decals on the lift if unable to read or missing. Reorder labels from BendPak.
- Refer to ANSI/ALI ALOIM booklet for periodic inspection checklist and maintenance log sheet.

Safe Lift Operation

Automotive and truck lifts are critical to the operation and profitability of your business. The safe use of this and other lifts in your shop is critical in preventing employee injuries and damage to customer's vehicles. By operating lifts safely you can insure that your shop is profitable, productive and safe.

Safe operation of automotive lifts requires that only trained employees should be allowed to use the lift.

TRAINING SHOULD INCLUDE, BUT NOT LIMITED TO:

- ◆ Proper positioning of the vehicle on the runway. (See manufacturers minimize wheel base loading requirements.)
- ◆ Use of the operating controls.
- ◆ Understanding the lift capacity.
- ◆ Proper use of jack stands or other load supporting devices.
- ◆ Proper use, understanding and visual identification of safety lock devices and their operation.
- ◆ Reviewing the safety rules.
- ◆ Proper housekeeping procedures (lift area should be free of grease, oil, tools, equipment, trash, and other debris)
- ◆ A daily inspection of the lift should be completed prior to its use. Safety devices, operating controls, lift arms and other critical parts should be inspected prior to using the lift.
- ◆ All maintenance and repairs of the lift should be completed by following the manufacturer's requirements. Lift repair parts should meet or exceed OEM specifications. Repairs should only be completed by a qualified lift technician.
- ◆ The vehicle manufacturer's recommendations should be used for spotting and lifting the vehicle.

LIFT OPERATION SAFETY

- ◆ It is important that you know the load limit. Be careful that you do not overload the lift . If you are unsure what the load limit is, check the data plate found on one of the lift columns or contact the manufacturer.
- ◆ The center of gravity should be followed closely to what the manufacturer recommends.
- ◆ Always make sure you have proper overhead clearance. Additionally, check that attachments, (vehicle signs, campers, antennas, etc.) are not in the way.
- ◆ Be sure that prior to the vehicle being raised, the doors, trunk, and hood are closed securely
- ◆ Prior to being raised, make sure there is no one standing closer than six feet from the lift
- ◆ After positioning the vehicle on the lift runways, set the emergency brake, make sure the ignition is off, the doors are closed, overhead obstructions are cleared, and the transmission is in neutral.
- ◆ Double check that the automatic chock devices are in position and then when the lift is raised, observe the chocks
- ◆ Put pads or adapters in the right position under the contact points that have been recommended
- ◆ The lift should be raised just until the vehicle's wheels are about one foot off the ground. If contact with the vehicle is uneven or it appears that the vehicle is not sitting secure, carefully lower the lift and readjust.
- ◆ Always consider potential problems that might cause a vehicle to slip, i.e., heavy cargo, undercoating, etc.
- ◆ Pay attention when walking under a vehicle that is up on the hydraulic lift.



- ◆ **DO NOT** Leave the controls while the lift is still in motion.
- ◆ **DO NOT** stand directly in front of the vehicle or in the bay when vehicle is being loaded or driven into position.
- ◆ **DO NOT** Go near vehicle or attempt to work on the vehicle when being raised or lowered.
REMAIN CLEAR of lift when raising or lowering vehicle.
- ◆ **DO NOT** rock the vehicle while on the lift or remove any heavy component from vehicle that may cause excessive weight shift.
- ◆ **DO NOT** lower the vehicle until people, materials, and tools are clear.
- ◆ **ALWAYS INSURE** that the safeties are engaged before any attempt is made to work on or near vehicle.
- ◆ Some vehicle maintenance and repair activities may cause the vehicle to shift. Follow the manufacturer's guidelines when performing these operations. The use of jack stands or alternate lift points may be required when completing some repairs.
- ◆ **READ AND UNDERSTAND** all safety warning procedures before operating lift.
- ◆ **KEEP HANDS AND FEET CLEAR.** Remove hands and feet from any moving parts. Keep feet clear of lift when lowering. Avoid pinch points.
- ◆ **ONLY TRAINED OPERATORS** should operate this lift. All non-trained personnel should be kept away from work area. Never let non-trained personnel come in contact with, or operate lift.
- ◆ **USE LIFT CORRECTLY.** Use lift in the proper manner. Never use lifting adapters other than what is approved by the manufacturer.
- ◆ **DO NOT** override self-closing lift controls.
- ◆ **CLEAR AREA** if vehicle is on danger of falling.
- ◆ **STAY ALERT.** Watch what you are doing. Use common sense. Be aware.
- ◆ **CHECK FOR DAMAGED PARTS.** Check for alignment of moving parts, breakage of parts or any condition that may affect its operation. Do not use lift if any component is broken or damaged.
- ◆ **NEVER** remove safety related components from the lift. Do not use lift if safety related components are damaged or missing.
- ◆ When the lift is being lowered, make sure everyone is standing at least six feet away.
- ◆ Be sure there are no jacks, tools, equipment, left under the lift before lowering.
- ◆ Always lower the vehicle down slowly and smoothly.

⚠ WARNING

Read and understand all safety warning and operation procedures before operating lift. Keep hands and feet clear from moving parts.

OPERATION INSTRUCTIONS

TO RAISE LIFT

- Clear area of personnel and make sure lift is in full lowered position.
- Drive vehicle over lift making sure centerline of the vehicle is positioned properly over lift pads.
- Position lift pads underneath the vehicle making sure that they make secure contact with the factory recommended lifting points.
- Before raising, make sure the weight of the vehicle does not exceed rated capacity of lift.
- Depress the RAISE button to commence lifting.
- Raise lift until the vehicles tires clear the floor.
- Stop then check if vehicle is secure and the lifting pads are still in contact with the frame.
- Continue raising vehicle to desired height.
- Raise until the safety lock bars drop into the LOCKED position as described below.

TO LOWER LIFT

- Clear area before lowering lift.
- Raise the lift until the release cam drops into the UNLOCKED position as described below.
- Push the LOWERING handle until the lift starts to descend. Stay clear of lift area.
- Fully lower the lift and remove all lifting adapters before driving vehicle away.

⚠ WARNING

ALWAYS ensure that the safety is in LOCKED position before any attempt is made to work on or near the vehicle.

LOCKED POSITION

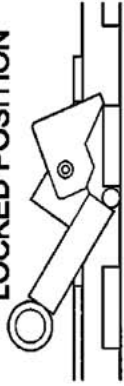

UNLOCKED POSITION



⚠ DANGER

THE MAXIMUM LIFTING CAPACITY FOR THIS LIFT IS DESCRIBED BELOW

Maximum Lifting Capacity

6000 Lbs. / 2722 Kg.

Maximum Lifting Capacity / Front Axle

3000 Lbs. / 1361 Kg.

Maximum Lifting Capacity / Rear Axle(s)

3000 Lbs. / 1361 Kg.

Exceeding the weight capacity of this lift can damage lift and/or property and may cause personal harm, injury or death to operators and/or bystanders. All vehicles MUST be positioned on lift with CENTER OF GRAVITY midway between adapters and/or centered on runways. Damage to lift due to overloading or misuse IS NOT covered under warranty.

SAFETY INSTRUCTIONS



Read operating and safety manuals before using lift.

SAFETY INSTRUCTIONS



Proper maintenance and inspection is necessary for safe operation.

SAFETY INSTRUCTIONS



Do not operate a damaged lift.

The messages and pictographs shown are generic in nature and are meant to generally represent hazards common to all automotive lifts regardless of specific style.

Funding for the development and validation of these labels was provided by the Automotive Lift Institute, PO Box 33116 Indialantic, FL. 32903.

They are protected by copyright. Set of labels may be obtained from ALI or its member companies.

© 1992 by ALI, Inc.

ALI/WL200s

WARNING



Clear area if vehicle is in danger of falling.

WARNING



Remain clear of lift when raising or lowering vehicle.

WARNING



Keep clear of pinch points when lift is moving.

WARNING

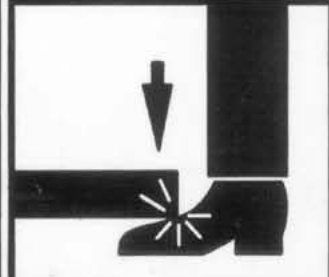

Keep feet clear of lift while lowering.

CAUTION



Lift to be used by trained operator ONLY.

CAUTION



Authorized personnel only in lift area.

WARNING



Do not override self-closing lift controls.

WARNING



Chock wheel to prevent vehicle movement.

The messages and pictographs shown are generic in nature and are meant to generally represent hazards common to all automotive lifts regardless of specific style.

Funding for the development and validation of these labels was provided by the Automotive Lift Institute, PO Box 33116 Indialantic, FL. 32903.

They are protected by copyright. Set of labels may be obtained from ALI or its member companies.

© 1992 by ALI, Inc.

ALI/WL200c

The messages and pictographs shown are generic in nature and are meant to generally represent hazards common to all automotive lifts regardless of specific style.

Funding for the development and validation of these labels was provided by the Automotive Lift Institute, PO Box 33116 Indialantic, FL. 32903.

They are protected by copyright. Set of labels may be obtained from ALI or its member companies.

© 1992 by ALI, Inc.

ALI/WL200w

LIFT WILL NOT RAISE

POSSIBLE CAUSE

1. Air in oil, (1,2,8,13)
2. Cylinder binding, (9)
3. Cylinder leaks internally, (9)
4. Motor run backward under pressure, (11)
5. Lowering valve leaks, (3,4,6,10,11)
6. Motor runs backwards, (7,14,11)
7. Pump damaged, (10,11)
8. Pump won't prime, (1,8,13,14,3,12,10,11)
9. Relief valve leaks, (10,11)
10. Voltage to motor incorrect, (7,14,11)

REMEDY

1. Check for proper oil level. The oil level should be up to the bleed screw in the reservoir with the lift all the way down.
2. Bleed cylinders. See Installation Manual
3. Flush- Release valve to get rid of. Hold release handle down and start unit possible contamination allowing it to run for 15 seconds.
4. Dirty oil. Replace oil with clean Dexron ATF.
5. Tighten all fasteners. Tighten fasteners to recommended torques.
6. Check for free movement of release. If handle does not move freely, replace bracket or handle assembly.
7. Check motor is wired correctly. Compare wiring of motor to electrical diagram on drawing.
8. Oil seal damaged or cocked Replace oil seal around pump shaft.
9. See Installation Manual Consult Lift Manufacturer.
10. Replace with new part Replace with new part.
11. Return unit for repair Return unit for repair.
12. Check pump-mounting bolts Bolts should be 15 to 18 ft. lbs.
13. Inlet screen clogged Clean inlet screen or replace.
14. Check wall outlet voltages and wiring Make sure unit and wall outlet are wired properly.

INSTRUCTION

MOTOR WILL NOT RUN

POSSIBLE CAUSE

1. Fuse blown, (5,2,1,3,4)
2. Microswitch burned out, (1,2,3,4)
3. Motor burned out, (1,2,3,4,6)
5. Voltage to motor incorrect, (2,1,8)

REMEDY

- | REMEDY | INSTRUCTION |
|---|--|
| 1. Check for correct voltage | .Compare supply voltage with voltage on motor nametag. Check that the wire is sized correctly. N.E.C. table 310-12 requires AWG 10 for 25 Amps. |
| 2. Check motor is wired correctly | .Compare wiring of motor to electrical diagram on drawing. |
| 3. Don't use extension cords | .According to N.E.C. : " The size of the conductors... should be such that the voltage drop would not exceed 3% to the farthest outlet for power..." Do not run motor at 115 VAC – damage to the motor will occur. |
| 4. Replace with new part | .Replace with new part. |
| 5. Reset circuit breaker/fuse | .Reset circuit breaker/fuse. |
| 6. Return unit for repair | Return unit for repair. |
| 7. See Installation Manual | .See Installation Manual. |
| 8. Check wall outlet voltage and wiring | Make sure unit and wall outlet is wired properly. Motor must run at 208/230 VAC. |

LIFT LOWERS SLOWLY OR NOT AT ALL

POSSIBLE CAUSE

1. Cylinders binding, (1)
2. Release valve clogged, (5,4,2,3)
3. Pressure fitting too long, (6)
4. Air in Cylinder (7)

REMEDY

- | REMEDY | INSTRUCTION |
|---|--|
| 1. See Installation Manual | .Consult Lift Manufacturer. |
| 2. Replace with new part | .Replace with new part. |
| 3. Return for repair | Return for repair. |
| 4. Check oil. | Use clean 10-WT hydraulic oil or Dexron-III automatic transmission fluid only. If ATF is contaminated, replace with clean ATF and clean entire system. |
| 5. Clean release valve | .Wash release valve in solvent and blow out with air. |
| 6. Replace fitting with short thread lead | Replace fitting with short thread lead. |
| 7. Bleed cylinders. | See Installation Manual |

WILL NOT RAISE LOADED LIFT

POSSIBLE CAUSE

1. Air in oil, (1,2,3,4)
2. Cylinder binding, (5)
3. Cylinder leaks internally, (5)
4. Lift overloaded, (6,5)
5. Lowering valve leaks, (7,8,1,5,9)
6. Motor runs backwards, (10,12,9)
7. Pump damaged, (5,9)
8. Pump won't prime, (1,2,3,4,5,11,9)
9. Relief valve leaks, (8,5,9)
10. Voltage to motor incorrect, (10,12,5)

REMEDY

- | REMEDY | INSTRUCTION |
|--|--|
| 1. Check oil level | The oil level should be up to the bleed screw in the reservoir [with the lift all the way down.] |
| 2. Check/Tighten inlet tubes | Replace inlet hose assembly. |
| 3. Oil seal damaged or cocked | Replace oil seal and install. |
| 4. Bleed cylinders | See Installation Manual. |
| 5. See Installation Manual | Consult Lift Manufacturer. |
| 6. Check vehicle weight | Compare weight of vehicle to weight limit of the lift. |
| 7. Flush release valve | Hold release handle down and start unit allowing it to run for 15 seconds. |
| 8. Replace with new part | Replace with new part. |
| 9. Return unit for repair | Return unit for repair. |
| 10. Check motor is wired correctly | Compare wiring of motor to electrical diagram on power unit drawing. |
| 11. Inlet screen clogged | Clean inlet screen or replace. |
| 12. Check wall outlet voltage and wiring | Make sure unit and wall outlet is wired properly. |

LIFT WILL NOT STAY UP

POSSIBLE CAUSE

1. Air in oil, (1,2,3)
2. Check valve leaks, (6)
3. Cylinders leak internally, (7)
4. Lowering valve leaks, (4,5,1,7,6)
5. Leaking fittings, (8)

REMEDY

1. Check oil level The oil level should be up to the bleed screw in the reservoir with the lift all the way down.
2. Oil seal damaged and cocked Replace oil seal around pump shaft.
3. Bleed cylinder Refer to Installation Manual.
4. Flush release valve Hold release handle down and start unit allowing it to run for 15 seconds.
5. Replace with new valve Replace with new valve.
6. Return unit for repair Return unit for repair.
7. See Installation Manual Consult Lift Manufacturer.
8. Check complete hydraulic system for leaks. Tighten all hydraulics fittings and inspect all hoses.

INSTRUCTION



Optional LR-4A Arm Kit
Fits Model(s) LR-60, LR-60P, P-6 and P-6F Low-Rise Lifts

This easy to use arm kit adapts to fit Bend-Pak low-rise lift models LR-60, LR-60P, P-6 and P-6F. This specialty arm kit increase the versatility of these lift models by increasing the pad reach when servicing light-duty trucks or vans. Complete kit includes; (4) lift arms and (4) rubber lift blocks.

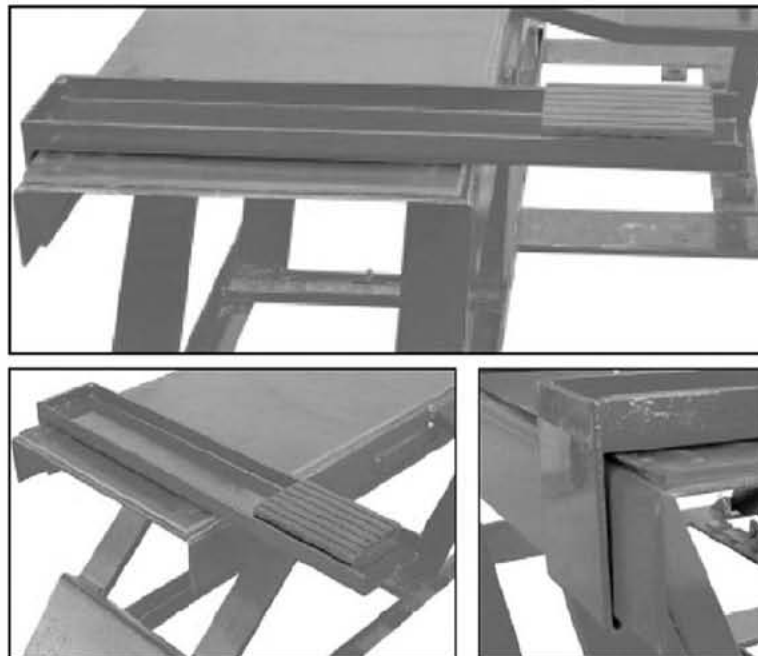

Bend-Pak, Bend-Pak Incorporated and Ranger Products and their respective logos are registered trademarks. Copyright 2005 Bend-Pak Incorporated

Bend-Pak / Ranger, 1645 Lemonwood Dr., Santa Paula, CA 93060
Tel: 1-805-933-9970 Fax: 1-805-933-9160

INSTALLATION FORM

Customer Name:		Date of Installation:	
Company Name:			
Street Address:			
City:	State:	Zip:	
Phone:		Fax:	
Pre-Install Agreement			
<p>I, (the undersigned) acting as the owner of the business listed above assume responsibility for any permits required, either state or county mandated, related to the installation and/or operation of this equipment. I assume responsibility for the concrete floor and condition thereof, now or later, where the above equipment model(s) are installed. I will assume all liability for losses, damages (including loss of use), expenses, demands, claims, and judgments in connection with or arising out of any personal injury or alleged damage to property, sustained or alleged to have been sustained in connection with, or to have arisen out of the condition and/or drilling of the concrete near or adjacent to the equipment model(s) listed above. If my employee(s) offer assistance of any kind during installation of the above equipment model(s) I hold the manufacturer and installation company harmless of all liability for losses, damages, expenses, claims, and judgments in connection with or arising out of any personal injury or alleged damage to property, sustained or alleged to have been sustained in connection with the installation of the above equipment model(s).</p> <p>I understand that the lifts above are supplied with concrete fasteners meeting the criteria of the American National Standard "Automotive Lifts - Safety Requirements for Construction, Testing, and Validation" ANSI/ALI ALCTV-1998, and that I will be responsible for all charges related to any special regional structural and/or seismic anchoring requirements specified by any other agencies and/or codes such as the Uniform Building Code (UBC) and/or International Building Code (IBC).</p>			
Customer Signature:		Print Name:	Date:
Post-Installation Check-Off			
<input type="checkbox"/> Base and Columns Properly Shimmed And Stable	<input type="checkbox"/> Lubrication of Critical Components		
<input type="checkbox"/> Anchor Bolts Tightened	<input type="checkbox"/> Lift Adapters		
<input type="checkbox"/> Runways Properly Attached and Secured	<input type="checkbox"/> Check For Overhead Obstructions		
<input type="checkbox"/> Electric Power Supply Confirmed	<input type="checkbox"/> Runways Level		
<input type="checkbox"/> Cables / Chains Adjusted Properly	<input type="checkbox"/> All Screws, Bolts, and Pins Secured		
<input type="checkbox"/> Safety Locks Functioning Properly	<input type="checkbox"/> Surrounding Area and Lift Clean In Appearance		
<input type="checkbox"/> Check For Hydraulic Leaks	<input type="checkbox"/> Proper Operation, Maintenance and Safety Explained		
<input type="checkbox"/> Oil Level	<input type="checkbox"/> Operation and Safety Manual(s) Left at Site		
<p>I, (the undersigned) confirm that the above installation procedure(s) were completed. I understand that I will be responsible for maintaining this equipment as outlined in the accompanied Installation and Operation Manual and ANSI/ALI ALOIM Safety Requirements for Operation, Inspection and Maintenance. I understand that personal injury and/or damage to property can occur if the above equipment model(s) are not maintained or used improperly and take full responsibility for training my employees on proper use and maintenance of this equipment. I hold the manufacturer and installation company harmless of all liability for losses, damages (including loss of use), expenses, demands, claims, and judgments in connection with or related to improper use, improper training, or lack of required maintenance. I understand that the warranty does not cover replacement of parts worn or damaged due to normal use or lack of required maintenance</p>			
Customer Signature:		Print Name:	Date:
Installer Signature:		Print Name:	Date:
Installer Company Name:			
Street Address:			
City:	State:	Zip:	
Phone:		Phone (Other):	



The best automotive service equipment on the planet.

For Parts Or Service
Contact:

Bend-Pak Inc. / Ranger Products
1645 Lemonwood Dr.
Santa Paula, CA. 93060

Tel: 1-805-933-9970
Toll Free: 1-800-253-2363
Fax: 1-805-933-9160

www.bendpak.com
www.rangerproducts.com

p/n 5900337

