

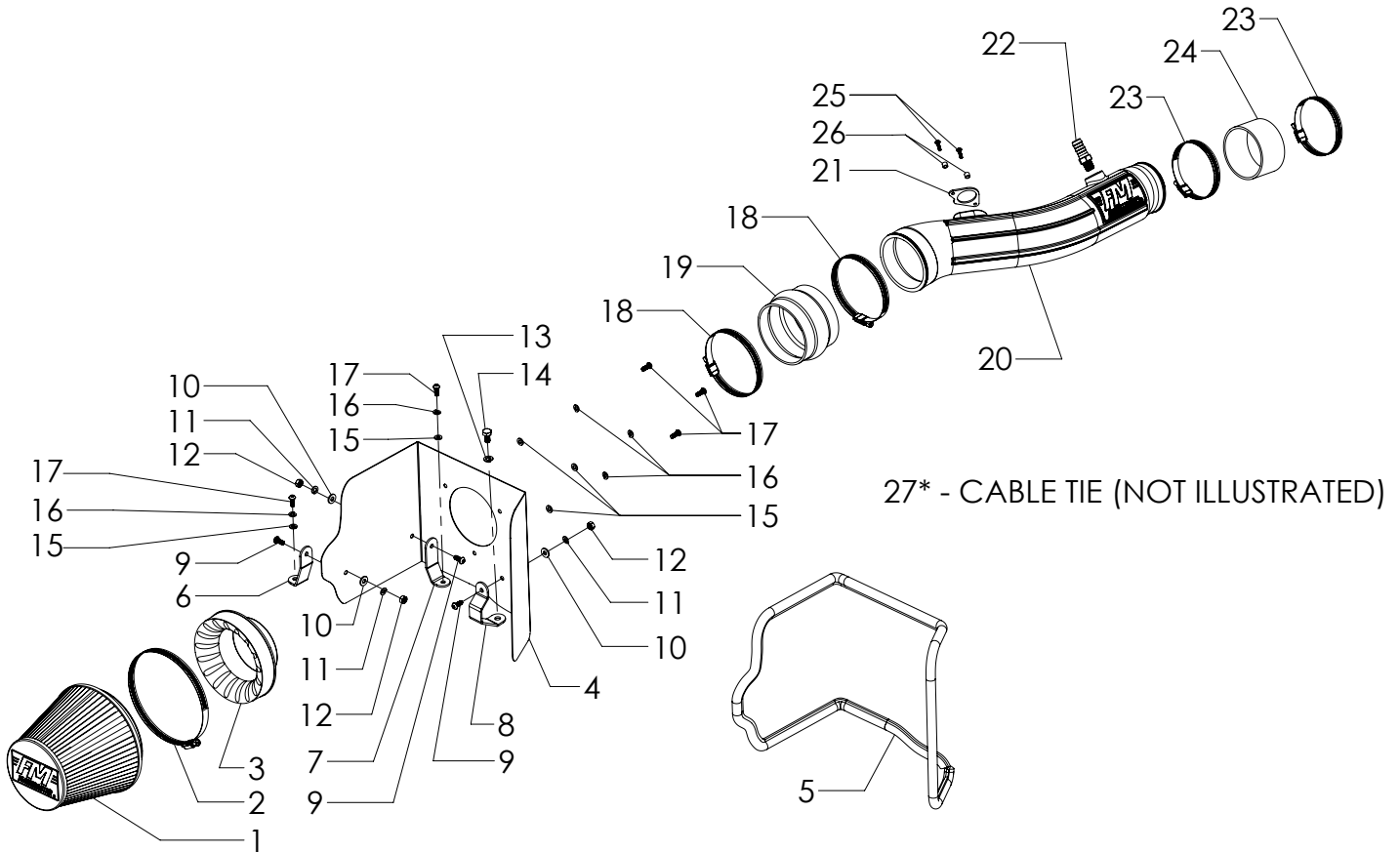

Installation Instructions for: SYSTEM # 615154 2016-2017 TOYOTA TACOMA with 3.5L V-6 Engine

NOT LEGAL FOR SALE OR USE ON ANY POLLUTION-CONTROLLED MOTOR VEHICLE IN CALIFORNIA OR IN STATES THAT HAVE ADOPTED CALIFORNIA EMISSION PROCEDURES.



REV. 11/8/17

ITEM NO.	PART NUMBER	DESCRIPTION	QTY.
1	AF1003	AIR FILTER, 6-5/8" x 6" DIA	1
2		SCREW CLAMP, #104 (4-1/8" - 7")	1
3	AF6002	ADAPTER, AIR FILTER 4" x 6"	1
4	AF3037	HEAT SHIELD, 16-17 TACOMA, 3.5L	1
5	49000061	GASKET, HEAT SHIELD	66"
6	AF5022	BRACKET 1, 16-17 TOYOTA TACOMA 3.5L	1
7	AF5023	BRACKET 2, 16-17 TOYOTA TACOMA 3.5L	1
8	AF5024	BRACKET 3, 16-17 TOYOTA TACOMA 3.5L	1
9	HW245	SCREW, 1/4"-20 x 5/8"	3
10	HW320	FLAT WASHER, 1/4"	3
11	HW322	LOCK WASHER, 1/4"	3
12	HW115	NUT, 1/4"-20	3
13	HW323	LOCK WASHER, M8	1
14	HW249	BOLT, M8 x 1.25 x 16MM	1

ITEM NO.	PART NUMBER	DESCRIPTION	QTY.
15	HW319	FLAT WASHER, M6	5
16	HW318	LOCK WASHER, M6	5
17	HW244	SCREW, M6 x 1.0 x 16MM	5
18	MC400H	SCREW CLAMP, #64 (3-9/16" - 4-1/2")	2
19	AF4005	COUPLER, FLEX 4" I.D. x 3" L	1
20	AF2037	INTAKE TUBE, 16-17 TACOMA, 3.5L	1
21	GA142	GASKET, MAF SENSOR, 16-17 TACOMA	1
22	AF4032	FITTING, STRAIGHT 5/8" BARB TO 1/4" NPT MALE	1
23	MC314H	SCREW CLAMP, #52 (2-13/16" - 3-3/4")	2
24	AF4025	COUPLER, STRAIGHT 3-1/4" I.D. x 2" L	1
25	HW259	SCREW, M4 x 0.7 x 16MM	2
26	HW525	SPACER, SS, 5/16" O.D. x 3/16" I.D. x 1/4" L	2
27*	HW526	CABLE TIE, 9-3/4" L x 1/8" W	1

REVIEW THE INSTRUCTIONS AND VERIFY THE KIT CONTENTS:

1. Please take a moment to read and understand these instructions before installing your Flowmaster cold air intake kit.



2. Use the parts drawing and list (front page) to verify your kit's contents.

In the unlikely event that any parts are missing, please contact Flowmaster Technical Support for replacements.

To simplify assembly and avoid cross-threading fasteners, identify and separate the 1/4-20 screws (item 9) (used with nuts (12)), and the M6 screws (17) (used with filter adapter (3)).

REMOVE THE FACTORY AIR INTAKE SYSTEM:

NOTES

- We highly recommend that you retain all factory air intake system parts.
- Please refer to vehicle manufacturer's recommendations regarding removal of factory components.
- Disconnecting the negative battery cable erases pre-programmed electronic memories. Write down all memory settings before disconnecting the negative battery cable. Some radios will require an anti-theft code to be entered after the battery is reconnected. The anti-theft code is typically supplied with your owner's manual. In the event your vehicle's anti-theft code cannot be recovered, contact an authorized dealership to obtain your vehicle's anti-theft code.

3. Turn off the vehicle's ignition and disconnect the negative battery cable.



4. Remove the engine appearance cover.

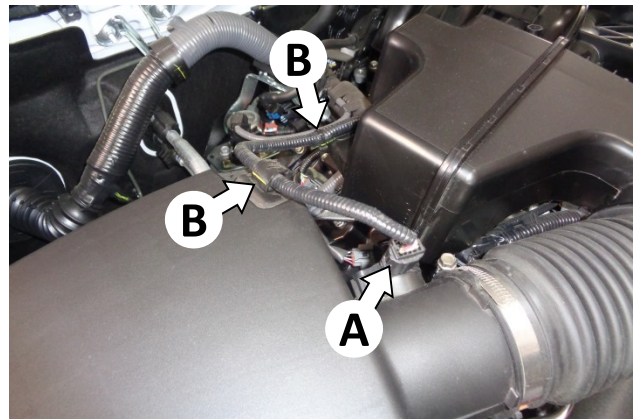

5. Disconnect the mass airflow (MAF) sensor plug (A), then release the two wire loom clips (B) from the airbox and intake duct.

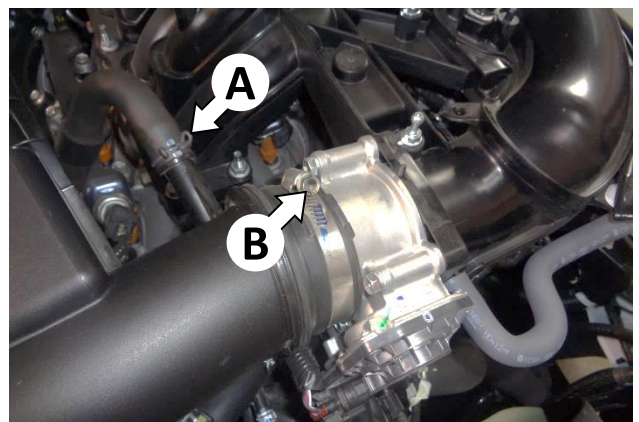

6. Disconnect the PCV hose (A) from the intake duct. (Leave the pinch clamp on the hose for later.) Then loosen the screw clamp (B) at the throttle body.



7. Separate the inlet duct from the throttle body, release the airbox clips, and remove the duct and top half of the airbox. Then remove the air filter.

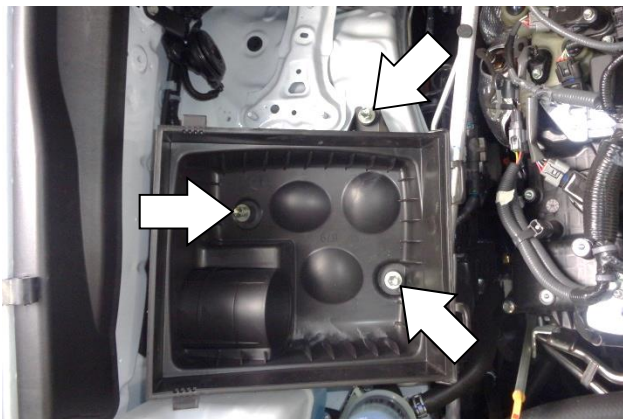

8. Remove the three bolts and the bottom half of the airbox.



9. Remove the mass airflow (MAF) sensor from the airbox. (Do not remove the o-ring from the sensor.) **CAUTION: The sensor is delicate!** Handle it with care, and store it in a safe location until reinstallation.

ASSEMBLE AND INSTALL YOUR FLOWMASTER COLD AIR INTAKE SYSTEM:

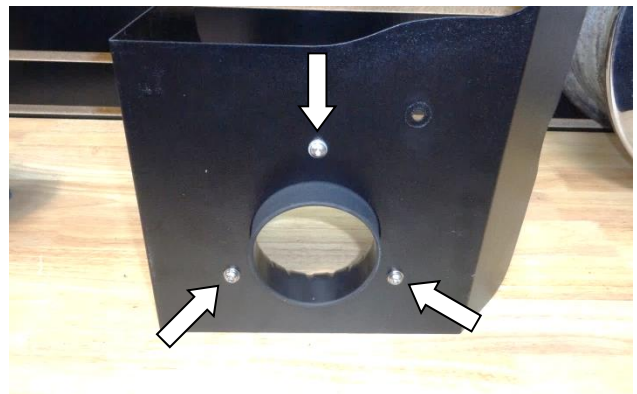

10. Assemble air filter adapter (3) to heat shield (4) using M6 screws (17), lock washers (16) and flat washers (15).



11. Attach gasket (5) to heat shield. Starting under the filter adapter, firmly press the gasket onto the edge, gradually working around the heat shield. When you return to the starting point, trim the gasket to fit using metal-cutting shears.



12. Identify heat shield brackets (6) and (7) as shown above.



13. Attach bracket (6) to the heat shield using a ¼-20 screw (9) (on the bracket side), and flat washer (10), lock washer (11) and nut (12) (on the heat shield side). **Do not fully tighten the fasteners at this time.**

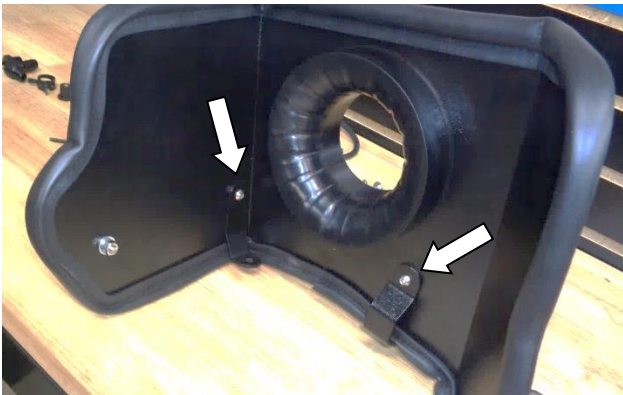

14. Attach brackets (7) and (8) to the heat shield using ¼-20 screws (9) (on the bracket side), and flat washers (10), lock washers (11) and nuts (12) (on the heat shield side). Note that bracket (8) passes under the edge of the heat shield. **Do not fully tighten the fasteners at this time.**

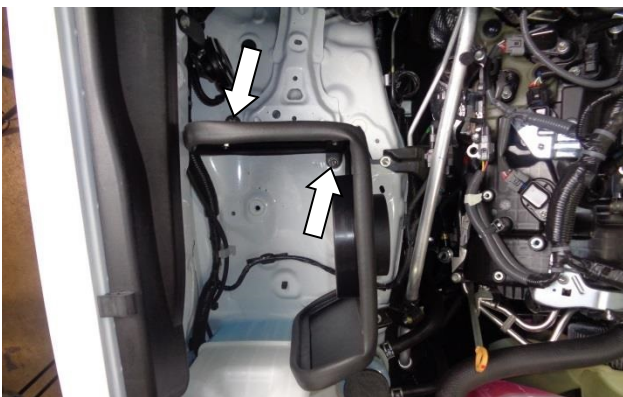

15. Install the heat shield in the vehicle. Fasten brackets (6) and (7) to the vehicle using M6 screws (17), lock washers (16) and flat washers (15).



16. Fasten bracket (8) to the vehicle using the M8 bolt (14) and lock washer (13). **After all 3 heat shield brackets are secured to the vehicle, tighten each bracket's fasteners to the heat shield.**



17. Apply 2 wraps of nylon thread tape to the 5/8" barbed fitting (24) and install it in the intake tube (20).

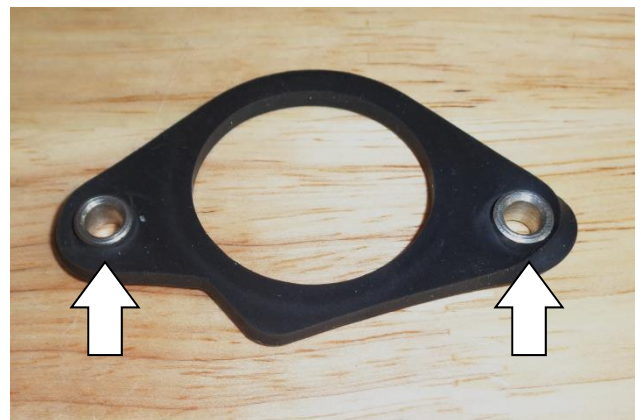

18. Push the spacers (26) into the holes of the MAF sensor gasket (21).



19. Place the assembled gasket and spacers over the MAF sensor as shown.



22. Install the two large screw clamps (18) on the large coupler (19), and install the coupler on the filter end of the intake tube. **Do not tighten clamps at this time.**



20. Install the assembled sensor, gasket and spacers in the intake tube using M4 screws (25).



23. Install the intake tube between the heat shield and the throttle body.



21. Install the two small screw clamps (23) on the small coupler (24), and install the coupler on the throttle body end of the intake tube. **Do not tighten clamps at this time.**

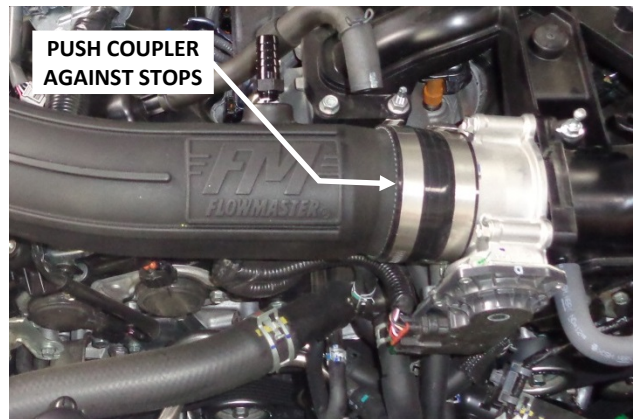

24. Push the right coupler up against the stops on the throttle body and tighten only the throttle body clamp.

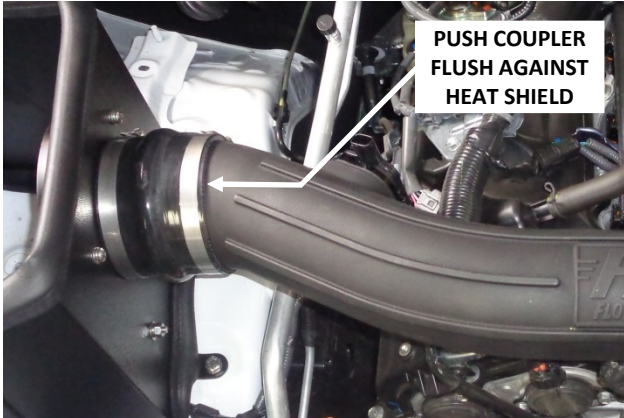

25. Push the left coupler up against the heat shield and tighten only the filter adapter clamp.

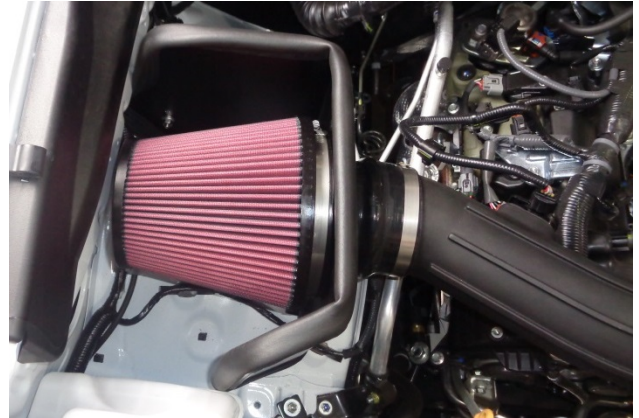

28. Place clamp (2) on air filter (1), install the filter on the filter adapter, and tighten the clamp.

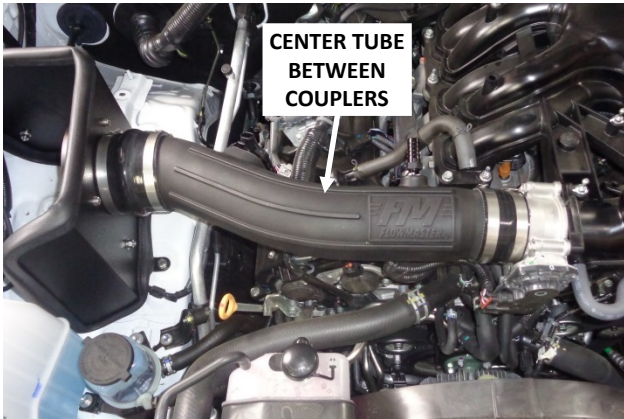

26. Center the intake tube between the couplers (so that there is roughly an equal amount of the tube inside each coupler), and tighten the two intake tube clamps.



29. Reinstall the engine appearance cover.

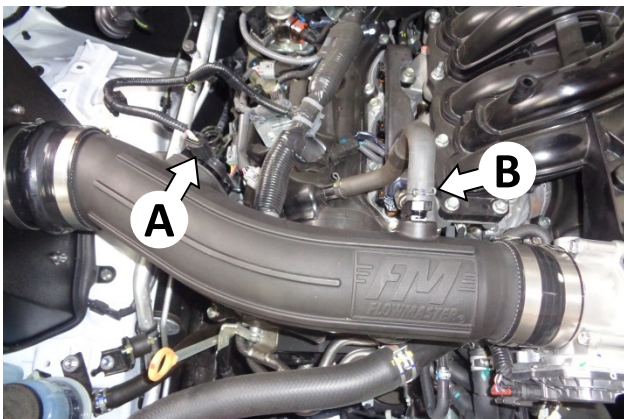

27. Connect the MAF sensor plug to the sensor (A) and check for security. Use cable tie (27) to secure excess sensor wire to the vehicle. Push the PCV hose onto the barbed fitting (B) and secure with the stock pinch clamp.



Congratulations, the installation of your FLOWMASTER cold air intake kit is now complete!