

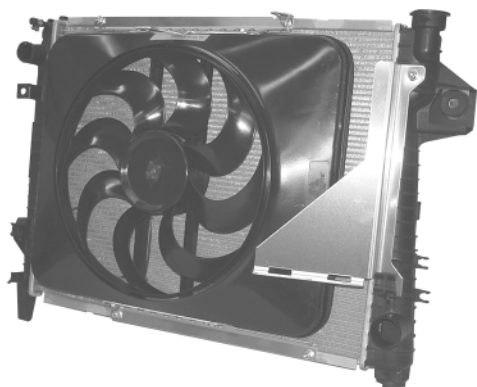

Dodge Ram '03-'08 Electric Fan Kit #183



Fits: 3.7 L. V6, 4.7 L. V8, & 5.7 L. V8 HEMI

INSTALLATION INSTRUCTIONS

REMOVAL OF EXISTING FAN AND SHROUD:

1. Make sure the engine is cool.
2. Disconnect negative (-) battery cable from battery.
3. Disconnect electrical connector attached to windshield washer motor on overflow tank. (*see Detail A*)
4. Disconnect electrical connector directly attached to base of overflow tank. (*see Detail A*)
5. Disconnect windshield washer fluid tubing from motor on overflow tank. **Note:** Be prepared to cap nipple of motor to prevent fluid from draining. (*see Detail A*)
6. Disconnect coolant overflow hose from radiator filler neck.
7. Remove bolts 2ea. securing top of overflow tank to shroud.
8. Lift and separate radiator overflow tank from shroud and set aside.

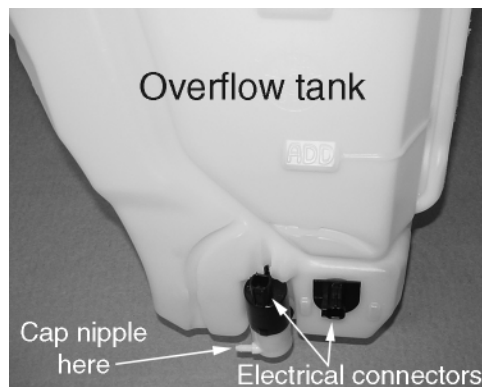

(Detail A)

This will be installed with the new fan kit later. **Note:** Be careful when setting aside tank as to not let it topple over and spill.

9. Remove bolts 2ea. holding the fan shroud to mounting bosses raised up from each of the two side tanks. Save 1ea. bolt for installation of overflow support bracket #18303 later. **Note:** Do not attempt to remove the shroud just yet. The fan / clutch assembly is in the way.

10. While holding clutch pulley, use a 36mm wrench & turn in direction of engine rotation (counter-clockwise) to loosen fan / clutch mounting-nut. Be careful not to drop fan / clutch assembly as it unscrews from pulley.

11. **Slowly** pull fan / clutch assembly **and** shroud up and out simultaneously. **Note:** Be careful not to scrape against the radiator core.

INSTALLATION OF NEW ELECTRIC FAN SHROUD:

12. An orange "Warning" sticker identifies top of shroud. Mount bracket #18301 to top side of shroud and bracket #18302 to bottom side of shroud. Leave brackets loose for adjustment later. Use the hex bolts and washers provided. (*see Detail B*)

13. On the radiator core bottom flange, (viewed from under the vehicle) there are two through bolts, securing accessories to the front of the radiator. Locate and remove the nuts (engine side of radiator) exposing bolt threads.

14. Lower Flex-a-lite electric fan / bracket assembly into engine compartment and loosely mount top bracket #18301 to the radiator core's top flange through holes. Use 2ea. t-bolts, washers, & Nylock nuts provided. (*see Detail C*)

15. Align bracket #18302 (from under side of radiator) to previously exposed bolt threads and loosely fasten using previously removed nuts along with washers provided. **Note:** You will notice that the new shroud is positioned towards the driver's side of radiator, this is intentional. The offset shroud placement allows for better air flow when the overflow tank has been reinstalled. (*see Detail D*)

16. Before tightening the brackets, adjust the fan so that the rubber seal is contacting the radiator core and compress the seal about 50%. It may help to have a friend hold the fan against the core while tightening brackets.

17. Place the lower tab of bracket #18303 into the side tank slot on passenger side. Slot is at bottom of radiator molded onto side tank. (*see Detail E*) Examine the old shroud's bottom mounting tabs for reference. While holding bottom of bracket #18303 in position, align top slot of bracket with side tank top mounting boss, and insert previously removed factory bolt to secure top of bracket. (*see step #9*)

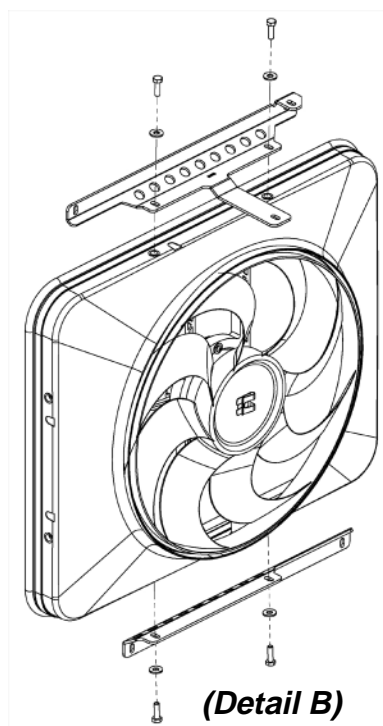

(Detail B)

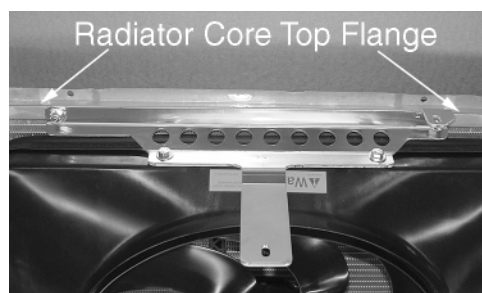

(Detail C)

INSTALLATION INSTRUCTIONS CONTINUED

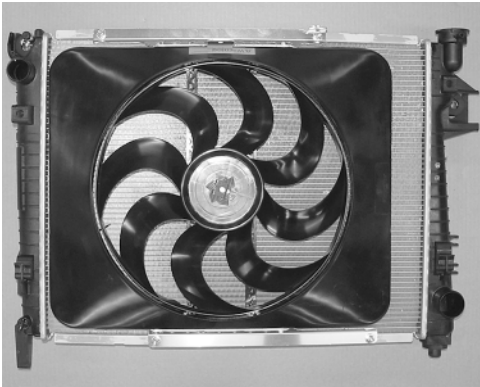

(Detail D)

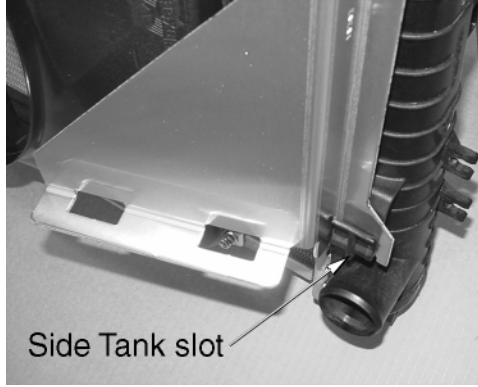

(Detail E)



(Detail F)

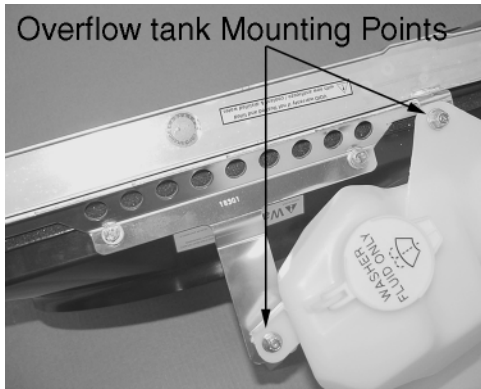

(Detail G)



#183 Assembly complete

18a. At this time you will want to reinstall the radiator overflow tank. Carefully lower the tank onto bracket #18303; align the two plastic fingers protruding from bottom of tank with location slots on bottom shelf of bracket. **(see Detail F)**

18b. Attaching the top of the overflow tank involves alignment of the tanks original mounting points 2ea. to bracket #18301. Secure overflow tank to bracket utilizing t-bolts, washers, & Nylock nuts provided. **(see Detail G)**

19. Reconnect coolant overflow hose to radiator filler neck.

20. Reconnect windshield washer fluid tubing to motor on overflow tank.

21. Reconnect electrical connector directly attached to base of overflow tank.

22. Reconnect electrical connector attached to windshield washer motor on overflow tank.

WIRING INSTRUCTIONS

WIRING CONNECTIONS

- #1 Battery Negative* (BLACK)
- #2 Negative to Fan* (PURPLE)
- #3 Positive to Fan* (YELLOW)
- #4 Battery Positive* (RED)
- #5 Negative Override Signal OFF
- #6 Negative Override Signal ON
- #7 A/C Compressor Negative Signal

- #8 A/C Compressor Positive Signal
- #9 Ignition Positive Signal*
- #10 Temp Sensor Wire*
- #11 Temp Sensor Wire*
- L1 Fan Output Indicator
- L2 Override Condition Indicator
- L3 A/C Signal Indicator
- L4 Ignition Signal Indicator

* mandatory connections

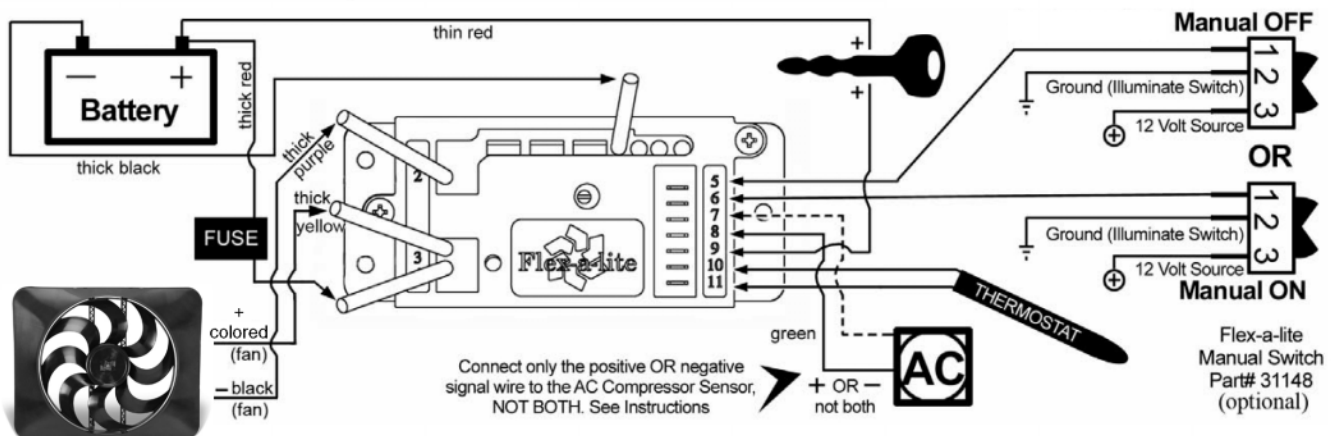
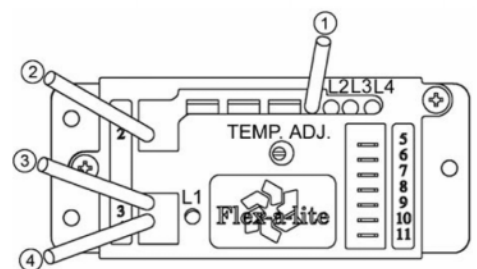

WIRING INSTRUCTIONS CONTINUED

1. Find the thick red and black wire in the kit. Determine the length needed to connect the red and black power leads on the VSC to the battery terminals and trim appropriately. Crimp a large yellow ring connector to the end of the black wire and connect to the negative (-) battery terminal. Connect the other end to the black wire on the VSC with a large butt connector (yellow sleeve).

2. Locate the fuse holder. **DO NOT INSTALL THE FUSE UNTIL ALL THE WIRING IS COMPLETE.** Attach a large ring connector to one end and a yellow insulated butt connector to the other end of the fuse holder. Attach the ring connector to the positive (+) terminal of the battery and connect the other end to the thick red wire found in the kit. Determine the length of wire needed to reach from the fuse holder to the red wire on the VSC and trim appropriately. Use a yellow insulated butt connector to connect this wire to the red wire on the VSC.

3. Find a circuit that is "hot", preferably in a fuse box, when the key is in the "on" position. Attach the included fuse tap to fuse. Attach a pink female connector to one end of the thin red wire (included) and connect to fuse tap. Determine length of wire needed to reach the VSC and trim to appropriate length. Attach a pink female connector to the end of the wire and connect to terminal #9 on VSC.

4. Locate wires going to A/C clutch. Determine which wire is ground and which is positive. Then attach supplied thin green wire by way of a piggyback connector to the positive wire that activates the clutch. Attach wire to terminal #8 on the VSC. Terminal #7 will be left open for this application.

5. Locate the temperature probe. Gently push the probe through fins in radiator as close to the upper radiator hose as possible with ¼"-½" of the probe protruding out of the front of the core. The rubber insulating cap should be used whenever possible to insulate any of the probe coming through the front side of the radiator. Determine length of wire needed to reach VSC. **IMPORTANT:** Strip the insulation on the temperature probe wires back about 1" and fold the wire on itself to effectively double the thickness of the wire before connecting spade connectors. Then attach these wires to terminals #10 & #11. Both wires need to be connected, but it doesn't matter which wire goes to each terminal.

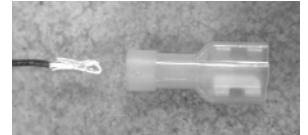

6. If manual switches (Flex-a-lite #31148) have been purchased, attach them as following. To override engine temperature to turn fans off, connect the switch to terminal #5 on VSC to send a ground signal. To override engine temperature to turn fans on, connect the switch to terminal #6 on the VSC so that a ground signal is sent.

7. Reconnect negative (-) battery cable to battery.

8. At this time install the provided fuse into fuse holder.

Initial Set-up and Adjustment

1. Turn ignition on. After 5-6 seconds, LED #4 should light up. If not, check to make sure that you have 12 Volts at terminal #9 on VSC. The delay is to allow starter to start the vehicle without the fans drawing any power.

2. With your engine running, engage the A/C. Your fan should come on and cycle with the A/C clutch. LED's #1, 3, and 4 should be lit when fans are running. If they do not turn on, verify that the A/C clutch is engaged and make sure that you have the appropriate wires connected to the correct terminals on the VSC. Shut off A/C and let engine continue to idle until it has reach normal operating temperature.

3. Verify that normal operating temperature has been reached by feeling upper radiator hose. Hot water should be flowing through the hose into the radiator. Adjust the screw on the VSC counterclockwise for a cooler setting or clockwise for a warmer setting. Once desired temperature is set, let engine continue to idle to make sure the fan will cycle to maintain desired temperature. When fan is running, LED's #1 and 4 should be lit.

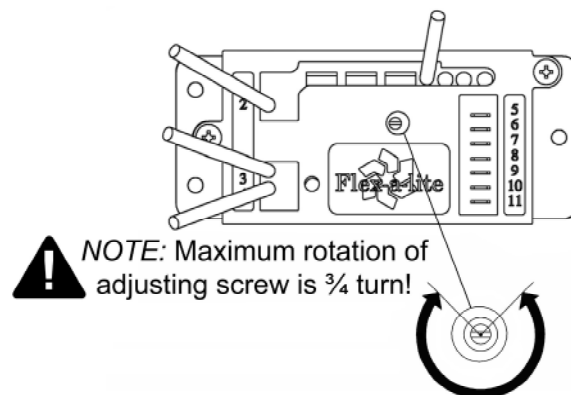

The Variable Speed Control has new features!

When you set the on temperature, the fans will come on at 60%; this reduces the load on your charging system. If the temperature rises, the fan speed will increase. If your set temperature is 185° F, then between 185° and 195° the fan speed will increase from 60% to 100%. So after a 10° rise from the set point, the fans will be running at 100%.

The Flex-a-lite Limited Warranty

Flex-a-lite Consolidated, 7213-45th St. Ct. E., Fife, WA 98424, Telephone No. 253-922-2700, warrants to the original purchasing user, that all Flex-a-lite products to be free of defects in material and workmanship for a period of 365 days (1 year) from date of purchase. Flex-a-lite products failing within 365 days (1 year) from date of purchase may be returned to the factory through the point of purchase, transportation charges prepaid. If, on inspection, cause of failure is determined to be defective material or workmanship and not by misuse, accidental or improper installation, Flex-a-lite will replace the fan free of charge, transportation prepaid. **Flex-a-lite will not be liable for incidental, progressive or consequential damages.** Some states do not allow the exclusion or limitation of incidental or consequential damages, so the above limitation or exclusion may not apply to you. This warranty gives you specific legal rights and you may have other rights, which vary from state to state. The Flex-a-lite warranty is in compliance with the Magnuson-Moss Warranty Act of 1975.

Troubleshooting the Variable Speed Controller

Problem	Possible Cause	How to find out	Solution
Fans do not turn on regardless of temperature.	Ignition wire not hooked up to proper source.	Make sure you have a switched source hooked up to terminal number 9. Turn your key on and LED #4 should light after 5-6 seconds.	If there is no light, then provide a 12 volt source to terminal number 9.
LED #4 lights up, but my fans still do not turn on.	Thermistor probe may not be hooked up properly.	Remove the thermistor probe from the circuit board. Place a jumper across terminals 10 & 11.	Remove the connectors and make sure that the 22 gauge wire is doubled up before the new connector is installed to ensure proper contacts.
I have tested the thermistor probe but the fans still do not turn on.	Fuse to battery positive post blown. Wires to terminals 1 & 4 aren't properly hooked up.	Inspect the fuse in the holder. Check for ground and power through lines hooked to terminals 1 & 4.	Replace fuse. Hook up wires for terminals 1 & 4 to ground and power, respectively, to battery.
Fans still do not come on.	Motors wired improperly.	Remove the wires from terminals 2 & 4 and hook them directly to power and ground to check motors.	Check wiring to motors to ensure they are wired properly. If motors do not spin after checking wiring to them, call tech support at 1-800-851-1510.
Fans come on and it seems like they are only at 100% instead of the initial 60%.	They are actually on at 60% and haven't reached 100% yet.	Ground terminal 6.	This is the fan at 100%
Fans do not come on until the temperature is very hot.	Thermistor probe not located in optimum position. Temperature set to high.	Check location of thermistor probe. Locate temperature screw in center of VSC. Note: maximum of rotation of screw is ¾ of a turn!	Thermistor should be located nearest the upper radiator hose. Turn adjustment screw until fans come on. Turning further in this direction will keep engine at a lower temperature.
Fans were working properly but have suddenly shut down.	Usage of a chassis ground and/or alternate source for power other than positive terminal on battery.	Trace wire from terminals 1 & 4 to find source.	Move to posts on the battery.
I turn my engine on and the fans come on but the engine is cold.	A/C lead hooked to the wrong terminal. A/C turned on.	Trace the wire hooked to either number 7 or 8 terminal and check polarity of the wire. Check if defrost activates a/c or if the a/c is on.	Hook the wire to the proper terminal on the a/c compressor and the corresponding terminal at the VSC. Shut off a/c or leave on as this is normal operation.

Rev. 01-24-06 99993