

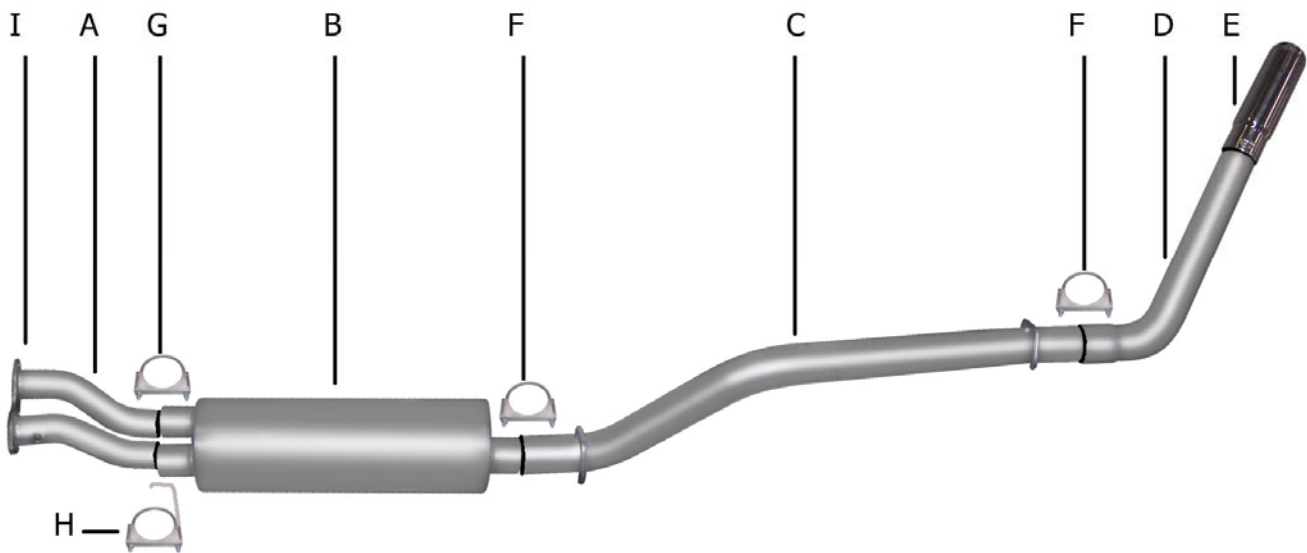

INSTRUCTION MANUAL
CAT-BACK SINGLE STAINLESS EXHAUST SYSTEM
96-00 CHEVY TRUCK 5.7L 2/4WD
STANDARD CAB, SHORT BED
PART # 615502



ITEM	PART #	QUANTITY	DESCRIPTION
A	523-700362S	1	STAINLESS HEADPIPE W/FLANGE #GP-96
B	758250S	1	SUPERFLOW STAINLESS MUFFLER
C	171-500607S	1	3" STAINLESS OVERAXLE TAILPIPE
D	117-50032RS	1	3" STAINLESS TURNOUT PIPE
E	500360	1	3-1/2" STAINLESS TIP
F	OHD300	2	3" CLAMP
G	5757	1	2-1/2" CLAMP
H	4174	1	FRONT HEADPIPE HANGER
I	9681	1	CONVERTER FLANGE GASKET

Will not fit on heavy duty truck.

Thank you for purchasing our GIBSON EXHAUST SYSTEM for your vehicle. If you need further assistance, please do not hesitate to call our Technical Department at (800) 528-3044, Monday through Friday, 8:00 am to 5:00 pm. 0706

EXHAUST INSTALLATION #615502

WHEN INSTALLING THIS EXHAUST SYSTEM MAKE SURE TO USE ALL THE PROPER SAFTEY PRECAUTIONS. USE JACK STANDS WHEN UNDER TRUCK. SET PARKING BRAKE, BLOCK TIRES AND USE SAFTEY GOGGLES.
DO NOT WORK WITH HOT PIPES!

SUGGESTED TOOLS

15MM SOCKET, 9/16" SOCKET, 1/2" SOCKET, 1/2" WRENCH, JACKSTAND, HACKSAW, WD-40, ANTI-SIEZE, HIGH TEMP O2 SENSOR SAFE GASKET SEALER

LAYOUT THE EXHAUST AND MATCH PART NUMBERS TO THE DRAWING.

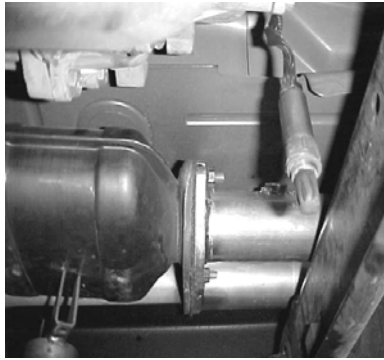

REMOVE O2 SENSOR FROM STOCK HEAD PIPE AND UN-BOLT STOCK HEADPIPE. YOU WILL REUSE YOUR STOCK NUTS AND BOLTS. CUT STOCK EXHAUST JUST BEHIND THE MUFFLER FOR EASIER REMOVAL. LEAVE ALL RUBBER GROMMETS IN PLACE. FOR EASIER REMOVAL OF HANGERS SPRAY WD-40 TO AID YOU IN REMOVING THEM. BOLT HEADPIPE #A TO STOCK FLANGE USING SUPPLIED FLANGE GASKET #I AND REUSING FACTORY BOLTS. APPLY A SMALL A MOUNT OF HIGH-TEMP O2 SENSOR SAFE SILICONE ON THE FLANGE TO PREVENT ANY LEAKS.



INSTALL THE OVERAXLE TAILPIPE #C INTO MUFFLER AT LEAST 1 1/2" TO 2" USING CLAMP #F . DO NOT TIGHTEN. INSERT WELDED HANGERS INTO RUBBER GROMMETS. THE SPARE TIRE ON SOME VEHICLES MAY NEED TO BE LOOSENED AND PULLED TO THE DRIVER SIDE AND RE-TIGHTENED. ROTATE PIPES UNTIL YOU HAVE AT LEAST A 1" CLEARANCE AWAY FROM ALL PIPES, ETC.



INSTALL TURNOUT PIPE #D INTO TAILPIPE USING CLAMP #F . INSTALL THE STAINLESS TIP AND CLAMP DOWN. USE ANY STAINLESS STEEL OR ALUMINUM CLEANER TO POLISH TIP.

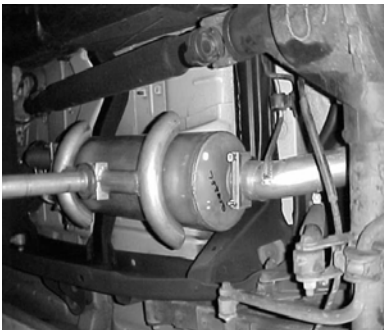

INSTALL MUFFLER TO HEADPIPES AND ATTACH CLAMP #G TO DRIVERSIDE AND CLAMP #H TO PASSENGER SIDE. INSERT HANGER INTO RUBBER GROMMET. MAKE SURE INLET AND MUFFLER IS LEVEL. NOW TIGHTEN DOWN. USE JACK STAND TO SUPPORT MUFFLER.



RE-INSTALL O2 SENSOR. USE A SMALL AMOUNT ANTI-SIEZE ON THE THREADS. NOW FIRMLY TIGHTEN ALL CLAMPS, HANGERS, FLANGE, AND BOLTS.

MAKE SURE YOU HAVE A 1" CLEARANCE AWAY FROM ALL FUEL LINES, BRAKE LINES, ETC. SHOCK, TIRES, ETC...