

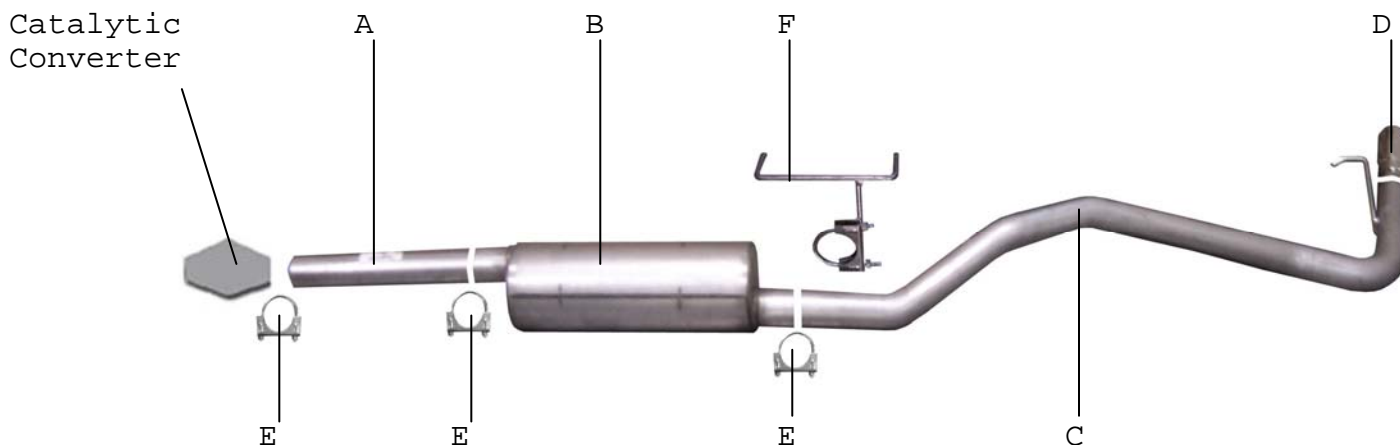

INSTRUCTION MANUAL
CAT-BACK STAINLESS SINGLE EXHAUST
01-04 TOYOTA TACOMA 3.4L S-RUNNER 2DR 2WD
XTRA CAB, SHORT BED
PART # 618706



ITEM	PART #	QTY	DESCRIPTION
A	257-700130S	1	2-1/2" STAINLESS HEADPIPE
B	788200S	1	SUPERFLOW STAINLESS MUFFLER
C	258-700129S	1	2.5" STAINLESS OVERAXLE TAILPIPE
D	500361	1	3" STAINLESS TIP
E	5757	3	2-1/2" CLAMP
F	4129	1	O.E. HANGER

Thank you for purchasing our GIBSON EXHAUST SYSTEM for your vehicle. If you need further assistance, please do not hesitate to call our Technical Department at 1-800-528-3044, Monday through Friday, 8:00 am to 5:00 PM. 0206

INSTRUCTION MANUAL

WHEN INSTALLING THIS EXHAUST SYSTEM MAKE SURE TO USE PROPER SAFETY PRECAUTIONS. USE JACKSTANDS WHEN UNDER THE VEHICLE, SET PARKING BRAKE, BLOCK TIRES AND USE SAFETY GLASSES.

DO NOT WORK WITH HOT PIPES!!!

SUGGESTED TOOLS:

9/16" SOCKET, 1/2" WRENCH, HACKSAW, JACKSTANDS, WD-40

LAY OUT THE GIBSON EXHAUST AND COMPARE PART NUMBERS WITH THE MANUAL.
LEAVE ALL FACTORY RUBBER GROMMETS IN PLACE. FOR EASIER REMOVAL OF HANGERS
SPRAY WD-40 ON THEM. CUT THE TAILPIPE BEHIND THE MUFFLER TO REMOVE STOCK EXHAUST

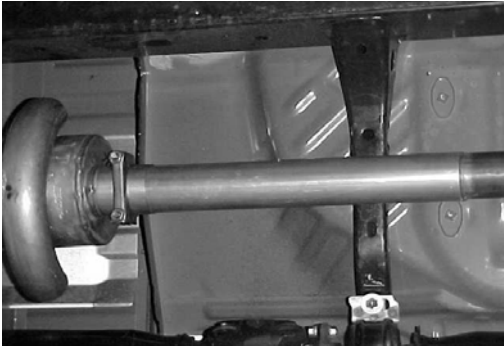

CUT STOCK EXHAUST 17-1/2" IN FRONT OF THE STOCK MUFFLER SLIDE THE HEADPIPE ONTO THE STOCK HEADPIPE USING CLAMP # E. THEN INSTALL THE MUFFLER ON HEADPIPE #A NO LESS THAN 1-1/2" TO 2" USING CLAMP #E. THE MUFFLER OUTLET WILL BE CLOCKED AT 12 O'CLOCK POSITION. INLET OF MUFFLER HAS LOUVERS FACING THE MOTOR.

DO NOT TIGHTEN.

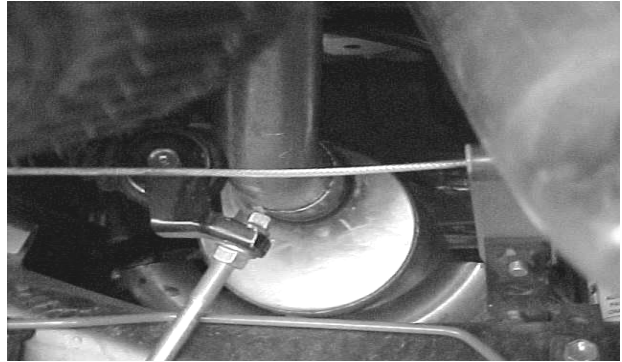

INSTALL OVERAXLE TAILPIPE # C INTO THE MUFFLER, USING CLAMP # E. INSERT WELDED HANGER INTO RUBBER GROMMET.

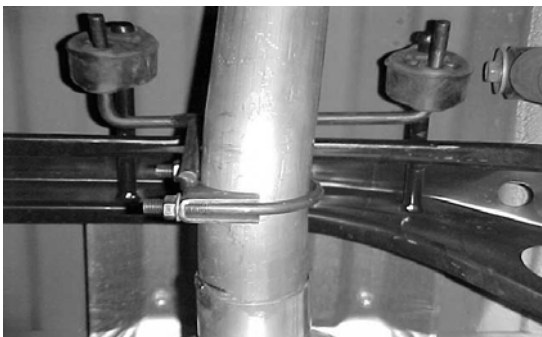

INSTALL REAR MUFFLER OF HANGER #F TO SUPPORT THE TAILPIPE. THE BOLTS FROM THE OE HANGER WILL BE FACING THE DRIVERSIDE. THIS HANGER ATTACHES TO THE TAILPIPE, NOT THE MUFFLER. DO NOT TIGHTEN.



INSTALL THE STAINLESS TIP. USE A STAINLESS OR ALUMINUM CLEANER TO POLISH TIP. NOW TIGHTEN ALL HANGERS AND CLAMPS.

MAKE SURE YOU HAVE A MINIMUM OF A 1" CLEARANCE FROM ALL BRAKE LINES, FUEL LINES, TIRES, SHOCKS, ETC.