



INSTRUCTION MANUAL

CAT-BACK SINGLE STAINLESS EXHAUST

95-97 FORD RANGER/MAZADA TRUCK

2.3L, 3.0L, 4.0L 2/4WD

EXTENDED CAB, SHORT BED

PART # 619711

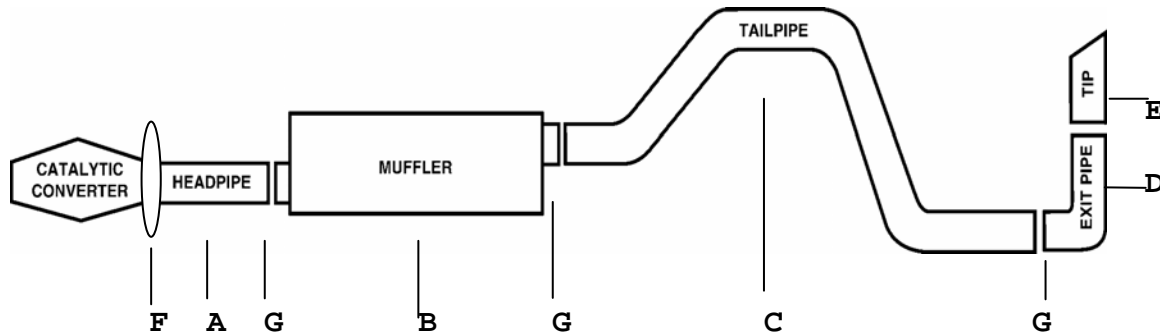

ITEM	PART #	QUANTITY	DESCRIPTION
A	216-25005S	1	2-1/2" STAINLESS HEADPIPE
B	788200S	1	SUPERFLOW STAINLESS MUFFLER
C	261-25002S-5	1	2-1/2" STAINLESS OVERAXLE TAILPIPE
D	214-25002S-A	1	2-1/2" STAINLESS TURNOUT PIPE
E	500361	1	3" STAINLESS TIP
F	GP-102	1	FLANGE
G	5757	3	2-1/2" CLAMP

Thank you for purchasing our GIBSON EXHAUST SYSTEM for your vehicle. If you need further assistance, please do not hesitate to call our Technical Department at (800) 528-3044, Monday through Friday, 8:00 AM to 5:00 PM. 0903

EXHAUST INSTALLATION

FORD RANGER

WHEN INSTALLING THIS EXHAUST SYSTEM, MAKE SURE TO USE PROPER SAFETY PRECAUTIONS. USE JACK STANDS WHEN UNDER THE TRUCK, BLOCK TIRES AND USE SAFETY GLASSES AND GLOVES. DO NOT WORK WITH HOT PIPES!

1. UNBOLT STOCK EXHAUST AT FLANGE BEHIND THE CATALYTIC CONVERTER. USE JACK STANDS TO SUPPORT CONVERTER SO IT WON'T DROP.
2. LAY OUT THE GIBSON EXHAUST SYSTEM ON THE FLOOR SO IT LOOKS LIKE THE DRAWING.
3. INSTALL HEADPIPE AND ATTACH TO STOCK FLANGE.
4. SLIDE MUFFLER WITH INLET TOWARDS THE CONVERTER ONTO THE HEADPIPE. USE A JACK STAND TO SUPPORT THE MUFFLER AND CLAMP DOWN BUT DO NOT TIGHTEN.
5. INSTALL THE OVERAXLE TAILPIPE.
6. SLIDE TURNOUT PIPE ON THE TAILPIPE BEHIND THE REAR TIRE AND CLAMP.
7. INSTALL STAINLESS TIP. TO CLEAN STAINLESS TIP, USE A SCOTT BRITE PAD AND ANY STAINLESS STEEL OR ALUMINUM CLEANER.
8. WHEN YOU HAVE EVERYTHING IN PLACE, TIGHTEN ALL BOLTS AND CLAMP DOWN.

SPECIAL NOTES:

- MAKE SURE YOU HAVE A 1" CLEARANCE ON ALL PIPES
- FROM ALL RUBBER BRAKE LINES, SHOCK BOOTS, TIRES, ETC...