

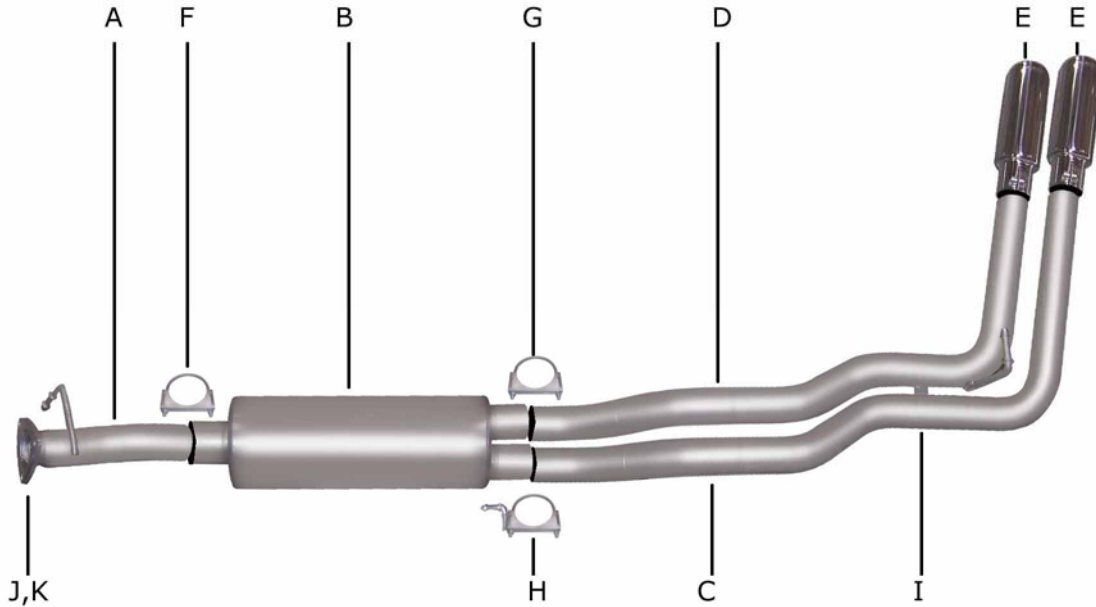

INSTRUCTION MANUAL
CAT-BACK STAINLESS DUAL SPORT EXHAUST
00-05 Chevrolet Astro Van 4.3L V6 2/4wd
PART # 65607



ITEM	PART #	QTY.	DESCRIPTION
A	948-700724S	1	3.00" Stainless Headpipe w/ GP-101, with welded hanger
B	758219S	1	Stainless SuperFlow Muffler
C	981-700761S	1	2.50"Stainless Driver Side over-axle tailpipe
D	982-700762S	1	2.50" Stainless Passenger Side over-axle tailpipe, with hanger
E	500374	2	3.50" Stainless tip
F	OHD300	1	3.00" Clamp
G	5757	1	2.50" Clamp
H	4253	1	Rear muffler hanger
I	BO-906	1	Bolt kit for tailpipes
J	BO-1048	1	Bolt kit for flange
K	9684	1	Flange Gasket

THANK YOU FOR PURCHASING OUR GIBSON EXHAUST SYSTEM FOR YOUR VEHICLE. IF YOU NEED FURTHER ASSISTANCE, PLEASE DO NOT HESITATE TO CALL OUR TECHNICAL DEPT. AT (800) 528-3044, MONDAY THROUGH FRIDAY, 8:00 AM TO 5:00 PM. 0506

EXHAUST INSTALLATION #665607

WHEN INSTALLING THIS EXHAUST SYSTEM, MAKE SURE TO USE PROPER SAFETY PRECAUTIONS. USE JACK STANDS WHEN UNDER TRUCK, SET PARKING BRAKE, BLOCK TIRES, AND USE SAFETY GLASSES AND GLOVES.
DO NOT WORK WITH HOT PIPES!

SUGGESTED TOOLS:

9/16" SOCKET, 15MM SOCKET, 1/2" WRENCH, 1/2" SOCKET, JACK STAND, HACKSAW, WD-40

LAY OUT THE GIBSON EXHAUST SO IT LOOKS LIKE THE DRAWING AND COMPARE THE PART NUMBERS.

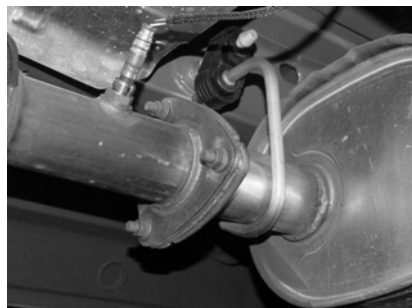

Lay out the exhaust on the floor so it looks like the drawing and compare the parts with the manual. To remove the stock exhaust, un-bolt it from the 3-bolt flange located in front of the muffler. **NOTE: For an easy removal of the exhaust, cut the tailpipe off behind the muffler.** Leave all rubber grommets in place. Use WD-40 to aid in removal.



Install the Driver side over-axle tailpipe #C into the muffler 1-1/2" to 2". Then insert the welded hanger into the rubber grommet. Use clamp #H to secure it to the muffler. **Do Not Tighten at this Time!**



Install your head-pipe # A onto your existing stock flange, use your supplied hardware #J & K in the kit. Use a jack stand to support the converter. Insert the welded hanger into the rubber grommet.

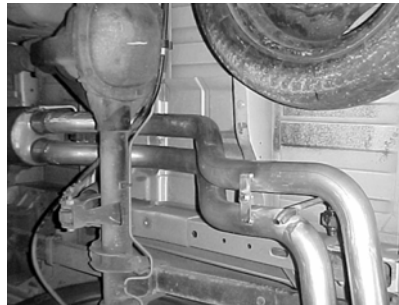

Install the Passenger side over-axle tailpipe # D to the muffler, 1-1/2" to 2". Use clamp # G to secure the tailpipe to the muffler. Use Bolt kit #I to attach the tailpipes together. **Do not Tighten at this Time!** Driver side tab will be on the bottom.

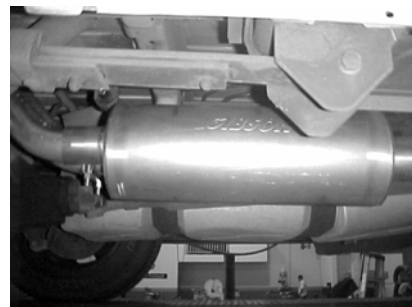

Install muffler #B onto head-pipe #A 1-1/2" to 2" with the louvers in the muffler facing towards the converter. Use a jack stand to support the muffler. Use Clamp #F to secure the muffler to the head-pipe. **Do Not Tighten at this Time!**



Install your Stainless Steel tips and clamp down. When you have everything in place *, firmly tighten all your hardware and clamps securely down. To clean your stainless steel tips, use a stainless cleaner and polish.



Install rear muffler hanger #H. Onto driver side outlet of the muffler, insert hanger into rubber grommet.

***MAKE SURE YOU HAVE A 1" CLEARANCE ON ALL BRAKE LINES, FUEL LINES, SHOCKS, TIRES, ETC...**