



# INSTRUCTION MANUAL

## CAT-BACK DUAL SPORT EXHAUST

03-06 TOYOTA TUNDRA 3.4L-4.7L 2/4WD  
 Double Cab, Short Bed

00-06 TOYOTA TUNDRA 3.4L-4.7L 2/4WD  
 Access Cab, Short Bed

### PART # 7100

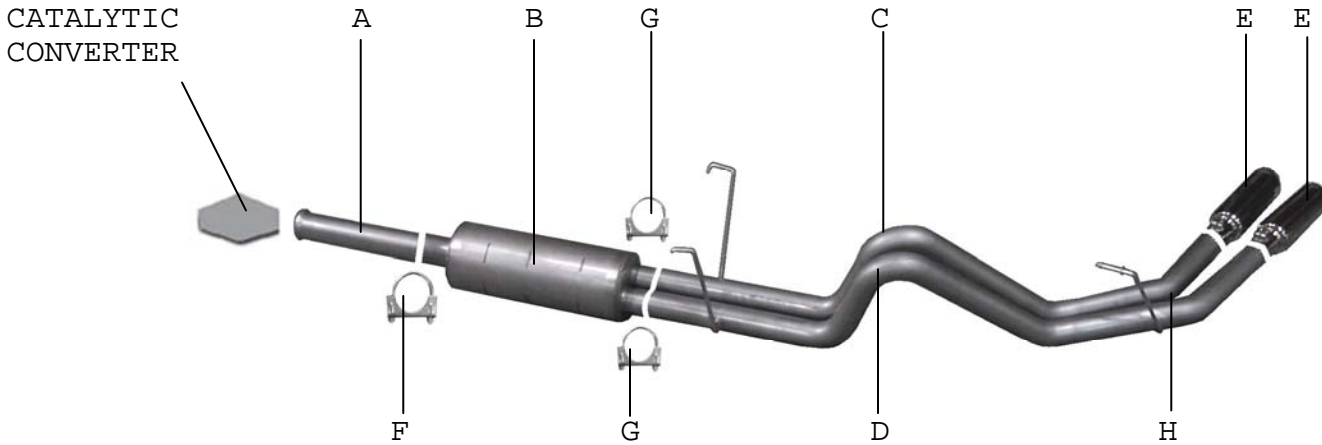

ITEM	PART #	QUANTITY	DESCRIPTION
A	700250	1	2 1/2" HEADPIPE
B	758216-2	1	DUAL OUTLET MUFFLER
C	700252	1	2 1/4" PASS.SIDE OVERAXLE TAILPIPE
D	700253	1	2 1/4" DRIV.SIDE OVERAXLE TAILPIPE
E	500395	2	3-1/2" STAINLESS TIPS
F	5757	1	2 1/2" CLAMP
G	5756	2	2 1/4" CLAMP
H	BO-906	1	BOLT KIT FOR TAILPIPE

Thank you for purchasing our GIBSON EXHAUST SYSTEM for your vehicle. If you need further assistance, please do not hesitate to call our Technical Department at (800) 528-3044, Monday through Friday, 8:00 am to 5:00 pm. 0106

# INSTALLATION INSTRUCTIONS

## PART #7100

WHEN INSTALLING THIS EXHAUST SYSTEM, MAKE SURE TO USE PROPER SAFETY PRECAUTIONS. USE JACK STANDS WHEN UNDER VEHICLE, SET PARKING BRAKE, BLOCK TIRES, AND USE SAFETY GLASSES AND GLOVES. DO NOT WORK WITH HOT PIPES!

### SUGGESTED TOOLS

12MM SOCKET & WRENCH, 9/16" SOCKET, 1/2" WRENCH, 1/2" SOCKET, HACKSAW, JACKSTAND

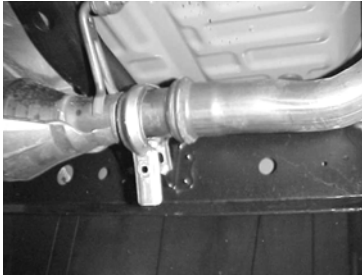

LAY OUT THE GIBSON EXHAUST ON THE FLOOR SO IT LOOKS LIKE THE DRAWING AND COMPARE PART NUMBERS. DISCONNECT THE FACTORY CLAMP IN FRONT OF THE STOCK MUFFLER AND REMOVE THE FACTORY EXHAUST. DO NOT DAMAGE THE FACTORY CLAMP. YOU WILL RE-USE IT. LEAVE ALL FACTORY RUBBER GROMMETS IN PLACE.

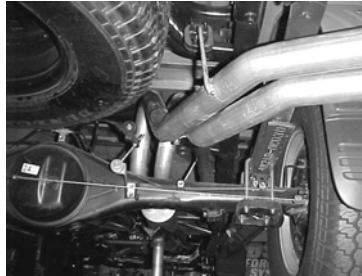

INSTALL THE DRIVERSIDE OVER AXLE TAILPIPE #D FROM THE REAR OF THE AXLE SLIP THE WELDED HANGERS INTO THE FACTORY RUBBER GROMMETS. THEN SLIP THE PIPE OVER THE OUTLET OF THE MUFFLER 1 1/2 TO 2". USE CLAMP # G TO SECURE TAILPIPES TO THE MUFFLER. DO NOT TIGHTEN.



INSTALL HEADPIPE #A ONTO THE FACTORY EXTENSION PIPE. MAKE SURE THAT THE HEADPIPE IS STRAIGHT, NOT ANGLED UP OR DOWN. YOU MAY WANT TO LIGHTLY TAP ON THE END OF THE PIPE TO ENSURE A TIGHT FIT.



USING THE BOLT KIT # H, BOLT BOTH TAILPIPES TOGETHER. THE PASSENGER TAILPIPE MOUNTING BRACKET WILL BE POSITIONED ON TOP OF THE DRIVERSIDE TAILPIPE. ROTATE PIPE'S UNTIL YOU HAVE A MINIMUM OF A 1" CLEARANCE ON ALL PIPES FROM RUBBER BRAKE LINES, TIRES, SHOCK BOOTS, ETC.



SLIP THE MUFFLER #B ONTO THE HEAD PIPE 1 1/2 TO 2". USE CLAMP #F TO ATTACH THE MUFFLER TO THE HEADPIPE. DO NOT TIGHTEN. MAKE SURE THE MUFFLER OUTLETS ARE LEVEL. USE A JACK STAND TO SUPPORT THE MUFFLER.

SPARE TIRE MAY NEED TO BE LOSSEMED AND PUSHED TO THE DRIVER SIDE TO GAIN CLEARANCE. THEN TIGHTEN ALL CLAMPS AND HANGERS.



SLIP PASSENGER SIDE OVER AXLE TAILPIPE #C OVER THE OUTLET OF THE MUFFLER 1 1/2 TO 2" . INSERT THE WELDED HANGER INTO THE FACTORY RUBBER GROMMET, AND ATTACH TO MUFFLER WITH CLAMP # G.



ONCE EVERYTHING IS POSITIONED INSTALL YOUR STAINLESS STEEL TIPS USE ANY ALUMINUM OR STAINLESS STEEL CLEANER TO POLISH YOUR TIPS.

**" MAKE SURE YOU HAVE A MINIMUM OF A 1 1/2" CLEARANCE FROM ALL BRAKE LINES, TIRES, SHOCKS, FUEL LINES ETC."**