



Holley Accessory Drive Kit

Part Numbers 20-163 & 20-163BK

(Kits include: 20-160, 20-165, & 20-166)

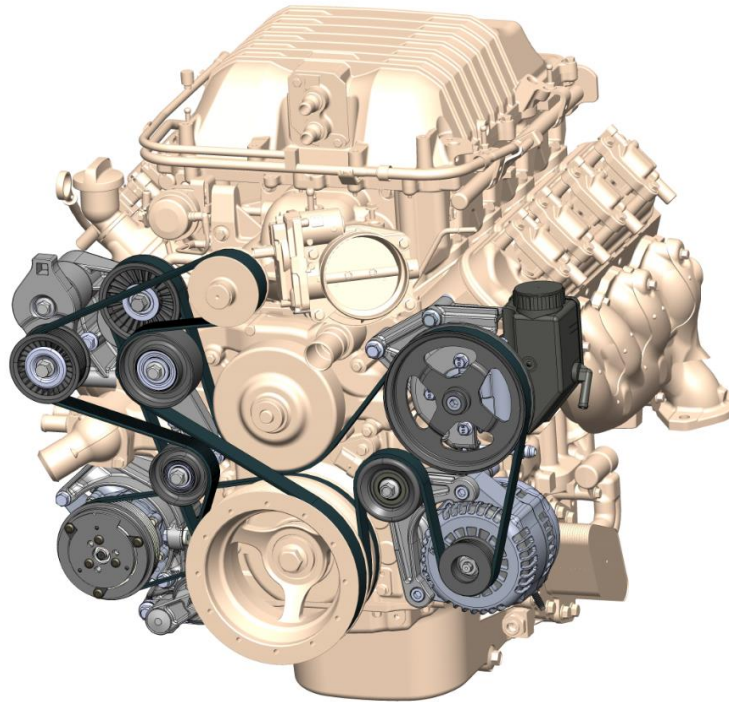
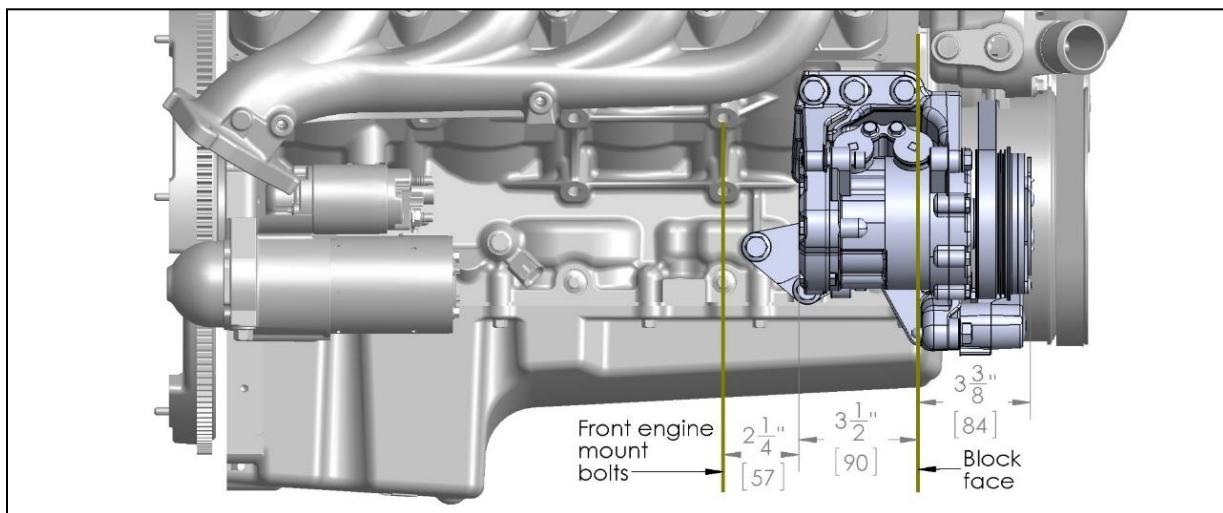
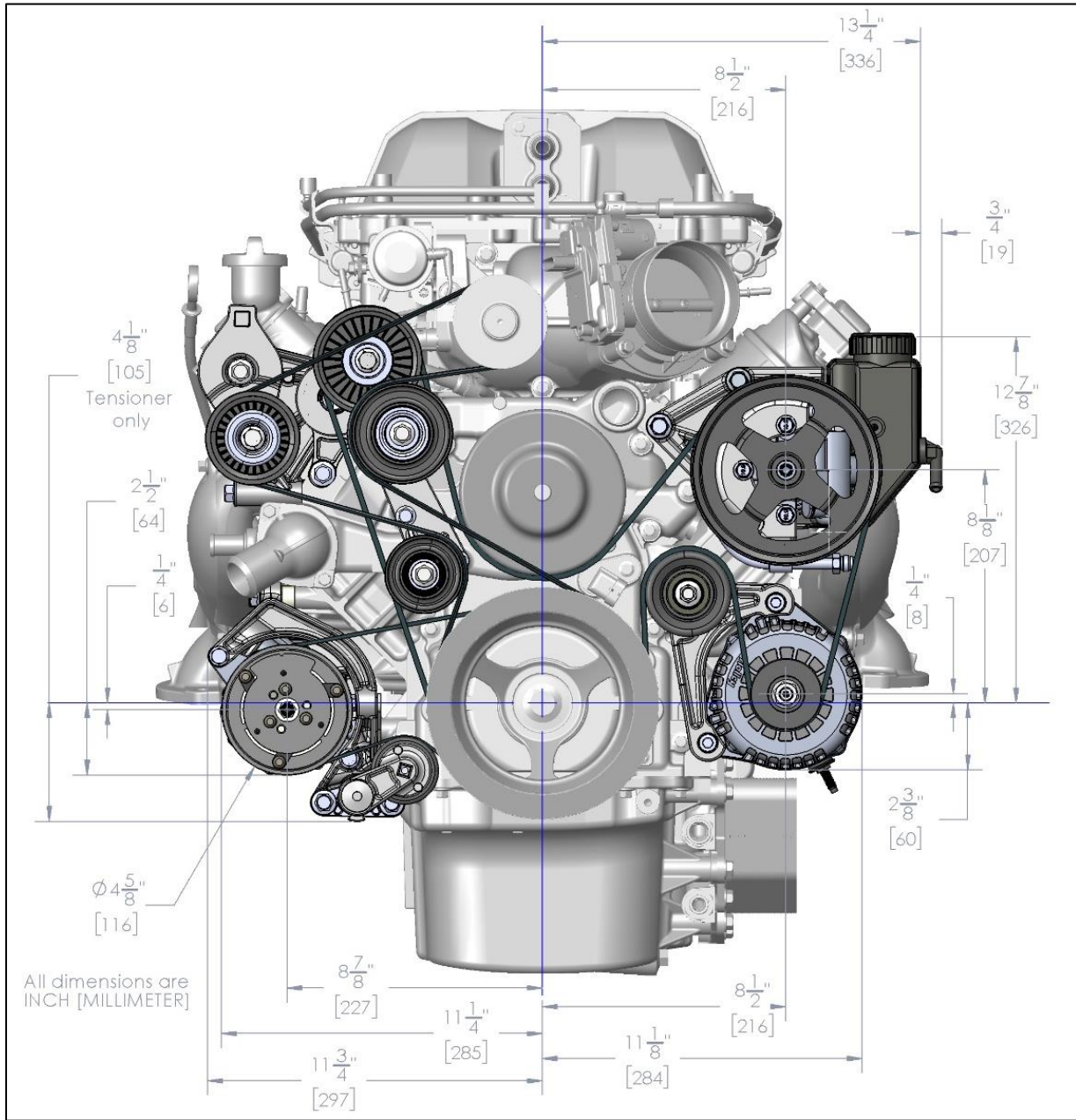

Table of Contents

Dimensions:.....	2
Introduction:.....	3
Parts List:	3
A/C Installation:	6
Alternator Installation:	6
P/S Pump/Reservoir Installation:	8
Accessory Belt Installation:.....	12
SC Belt Installation:	16
Belt Length Calculation:.....	19

Dimensions:









Introduction:

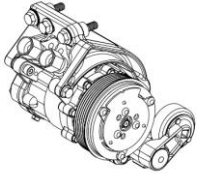
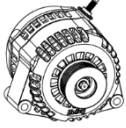

Holley's accessory drive kits offer clean, economical mounting of all LS engine accessories. These brackets pull all accessories in more toward the engine when compared to the original LSA accessories giving more clearance to swap applications and overall cosmetic appeal. These brackets look truly at home on the LSA engine as if they came from the factory this way. Holley's complete accessory drive systems come with virtually everything needed for installation, from the accessories to the pulleys and even the belt.

Note: This drive works with the original LSA damper/pulley and similar aftermarket versions.

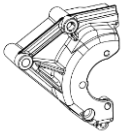
IMPORTANT NOTE IF PAINTING COMPONENTS: The alternator and A/C compressor ground through their mounting brackets. If painting or coating the brackets, the mating surfaces must all be bare metal allowing a ground path from the accessories' mounting feet to the engine block and ultimately the negative terminal on the battery.

Parts List:

PICTURE	QTY	DESCRIPTION	REPLACEMENT MANUFACTURER & P/N
	1	A/C Compressor and Bracket Assembly	Holley P/N 20-160
	1	Alternator	Holley 197-302 (natural) / 197-303 (black)
	1	Pigtails	Pigtails Holley 197-400
	1	Alternator Mounting Bracket with Hardware	Holley P/N 20-166
	1	P/S Pump	Holley P/N 198-101
	1	P/S Bracket with Hardware	Holley P/N 20-165
	1	P/S Hardline	Holley P/N 197-207

	1	P/S Pulley	Holley P/N 97-152
	1	Smooth Idler Pulley	Holley P/N 97-150
	1	SC Belt Tensioner	GM# 2622452
	1	Accessory Belt Tensioner	GM# 12628025
	1	SC Double Idler Bracket	GM# 12606501
	1	SC Tensioner Bracket	GM# 12606500
	1	Top SC Idler Large	GM# 12606031
	1	Bottom SC Idler Small	GM# 12606032
	1	Belt - Accessory	BANDO# 6PK2047
	1	Belt - SC	GM# 12676726

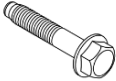
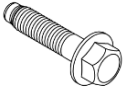
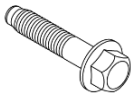
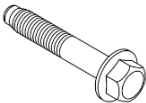
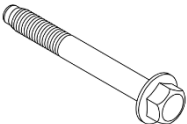
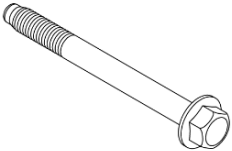
HARDWARE		Replacement Kit 97-263	Hardware Application
	1	Flange (13mm Hex Head) Bolt M8 x 1.25 x 25	Idler Pulley Bracket to Water Pump
	3	Flange (13mm Hex Head) Bolt M8 x 1.25 x 40	Double Idler Pulley Bracket to Water Pump
	2	Flange (15mm Hex Head) Bolt M10 x 1.5 x 40	Accessory Tensioner to Water Pump
	1	Flange (15mm Hex Head) Bolt M10 x 1.5 x 45	SC Tensioner to Head (Top Hole)
	2	Flange (15mm Hex Head) Bolt M10 x 1.5 x 55	Idler Pulley Bolts
	2	Flange (15mm Hex Head) Bolt M10 x 1.5 x 80	(1) SC Tensioner to Water Pump (1) SC Tensioner to Block
	1	Flange (15mm Hex Head) Bolt M10 x 1.5 x 100	SC Tensioner to Bracket

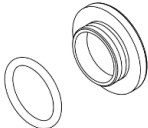
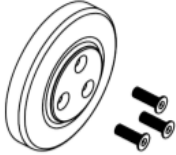
Included Only With: 20-163BK			
	1	Alternator Pulley Cover & O-ring (Black)	Holley P/N 97-187
	1	A/C Compressor Pulley Cover & Hardware (Black)	Holley P/N 97-185

A/C Installation:

Install A/C bracket in the **standard alignment position** at this time.

NOTE: For details on A/C Compressor and belt installation, see instructions for Holley P/N 20-160.

Alternator Installation:

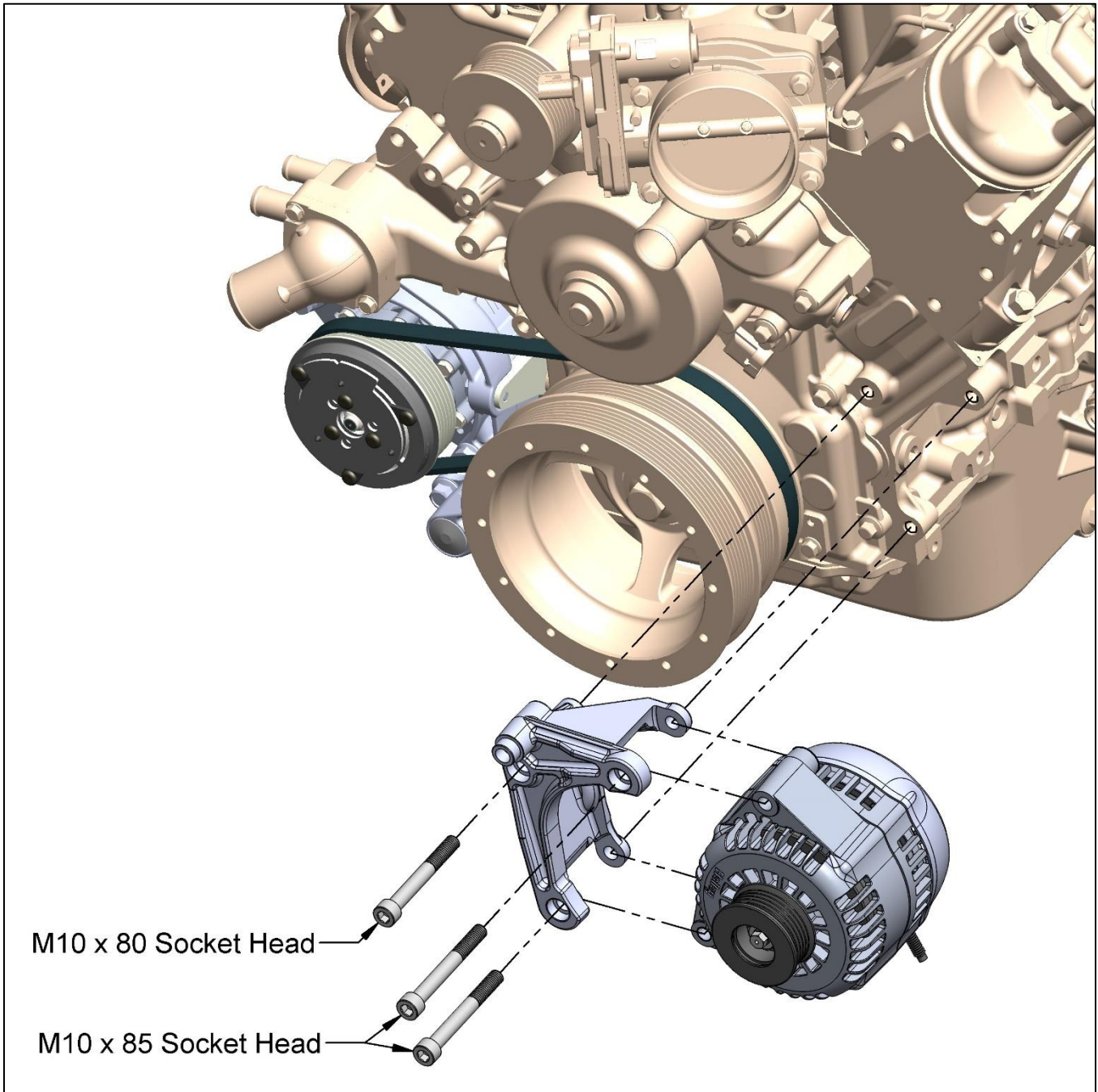

NOTE: Torque M10 bolts to 36 ft./lbs.

Helpful hint: When wiring the alternator, install the included 197-400 plug into the alternator. Next, connect the yellow wire to switched voltage that is “on” when the key is in the run position. If the vehicle has a “charge indicator light”, the yellow wire can be connected to that circuit.

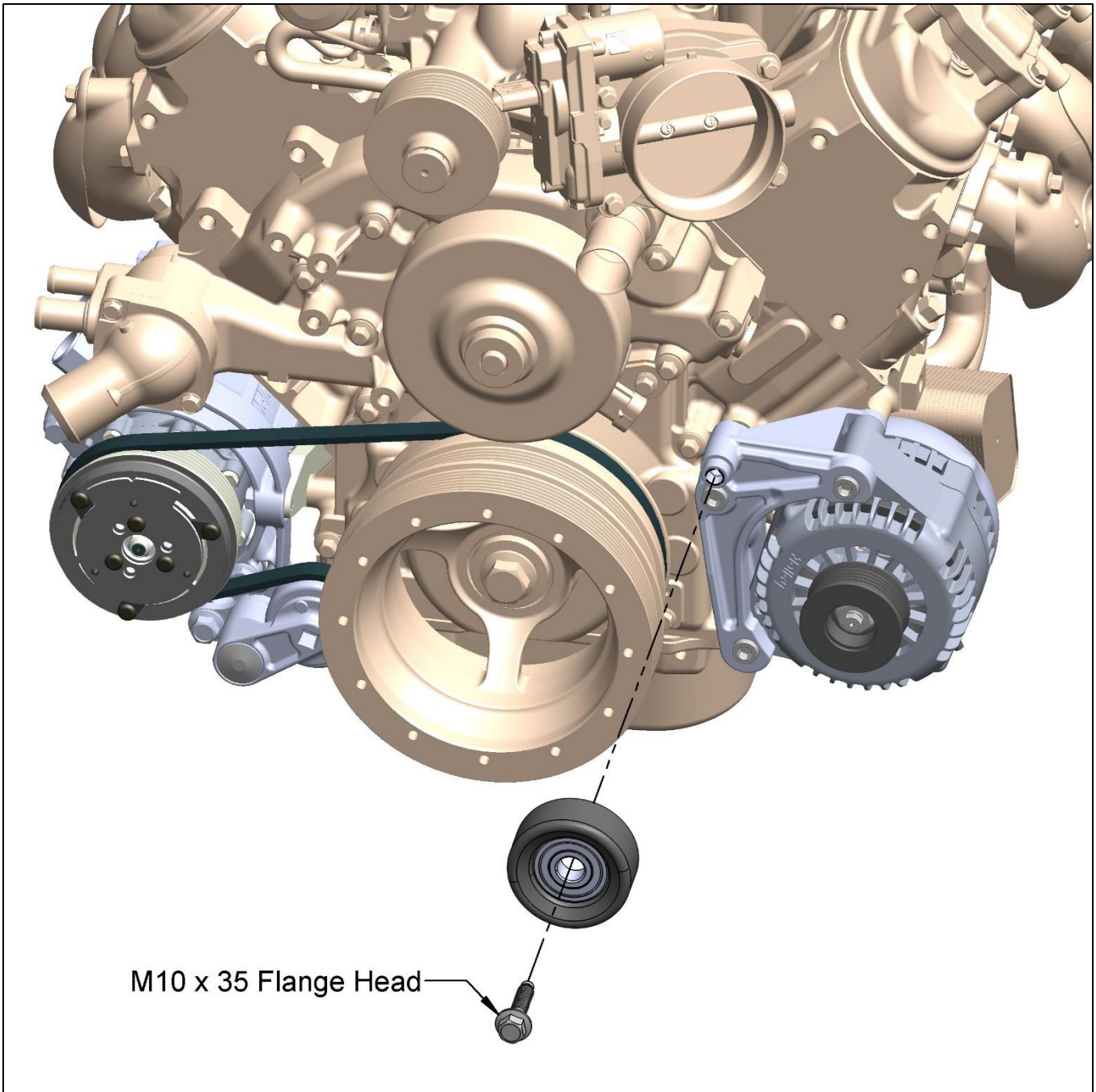

M10 x 35 Flange Head

NOTE: Torque M10 bolt to 36 ft./lbs.

P/S Pump/Reservoir Installation:

Install the 198-207 power steering AN adapter/tube and assemble at this time.

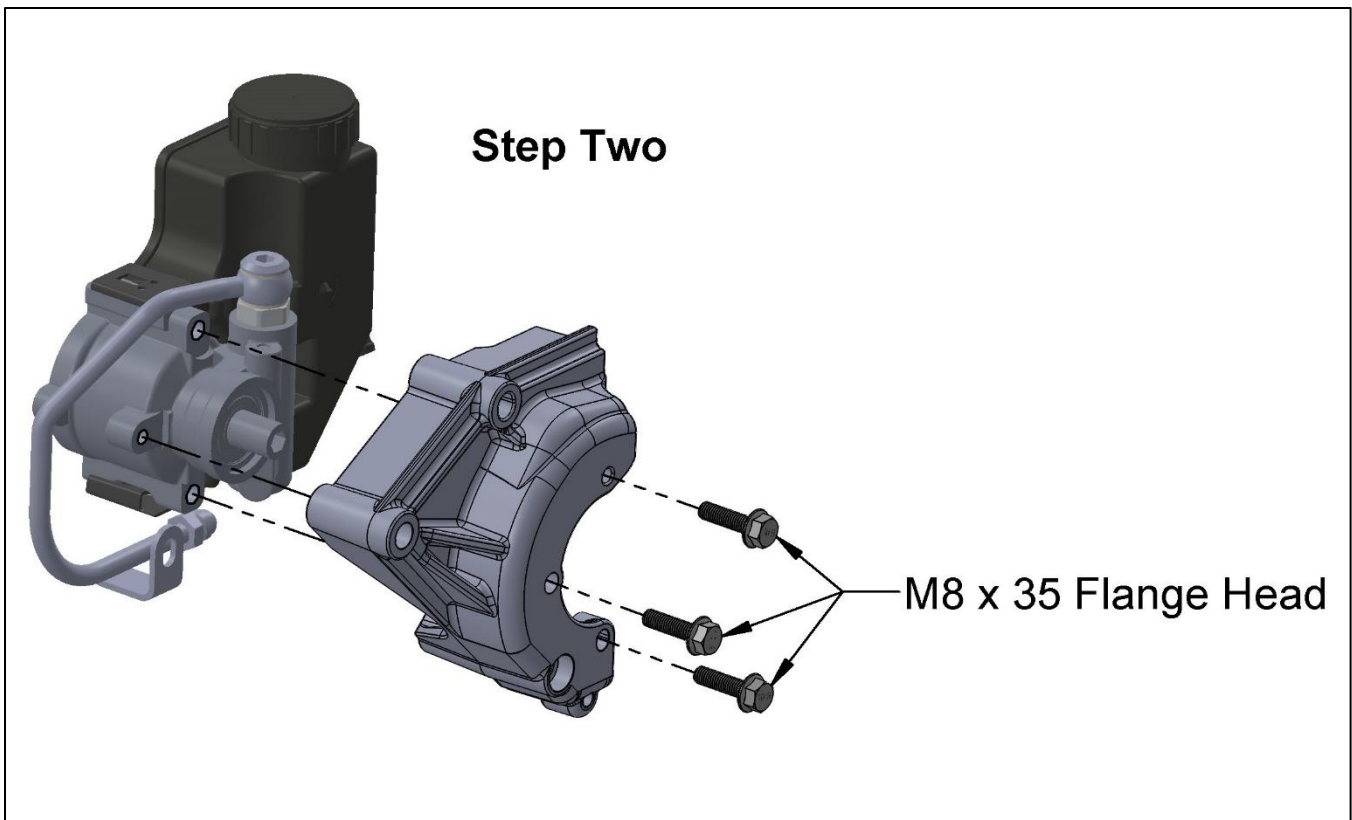
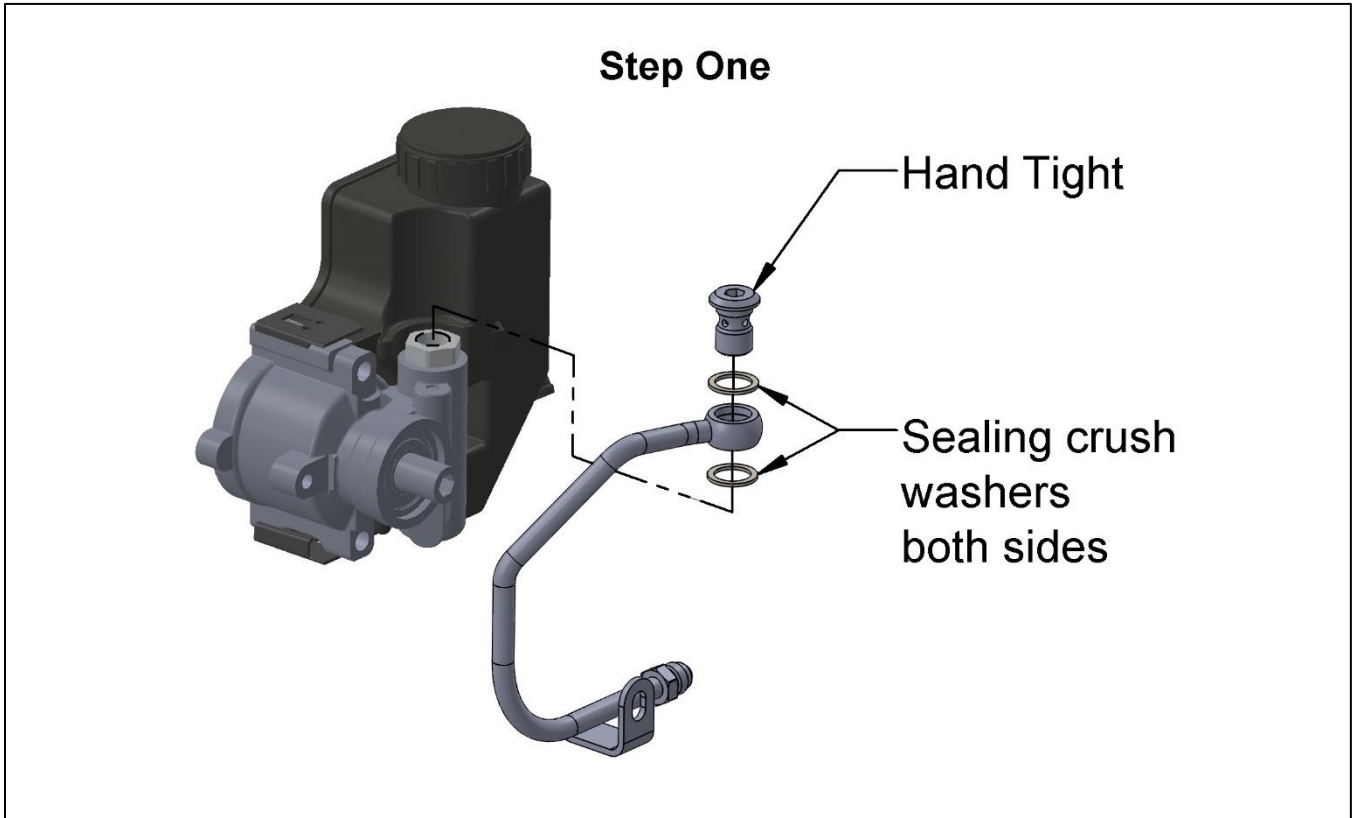

Step Three

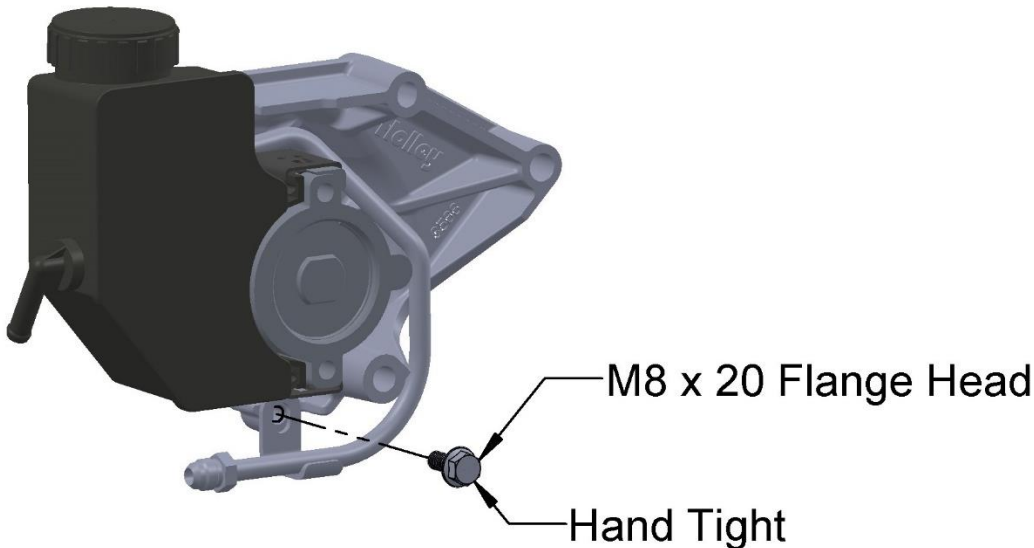

Step Four

Torque M8 bolts to 18 ft./lbs. and banjo bolt to 25 ft./lbs.

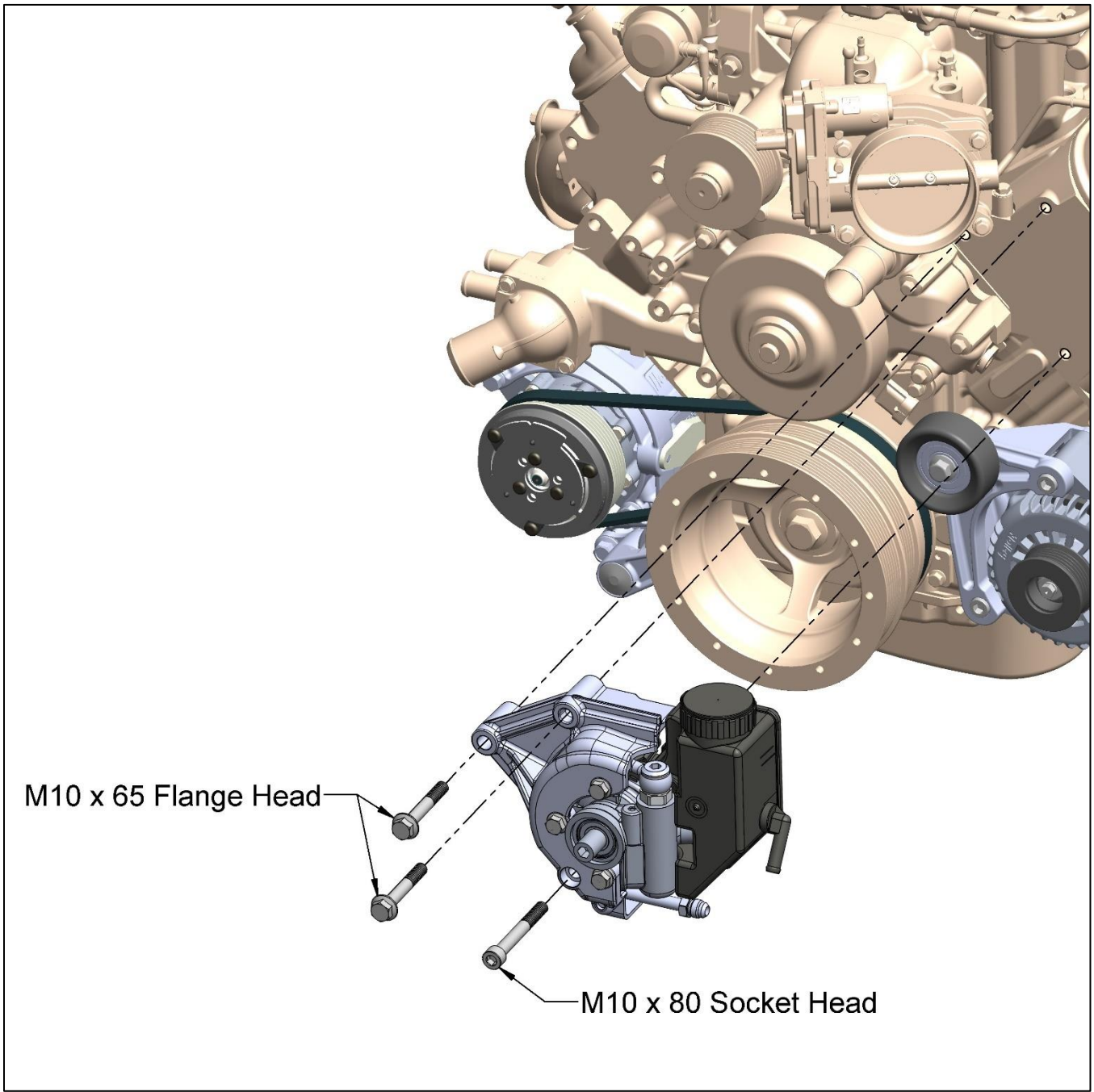

NOTE: Torque M10 bolts to 36 ft./lbs.

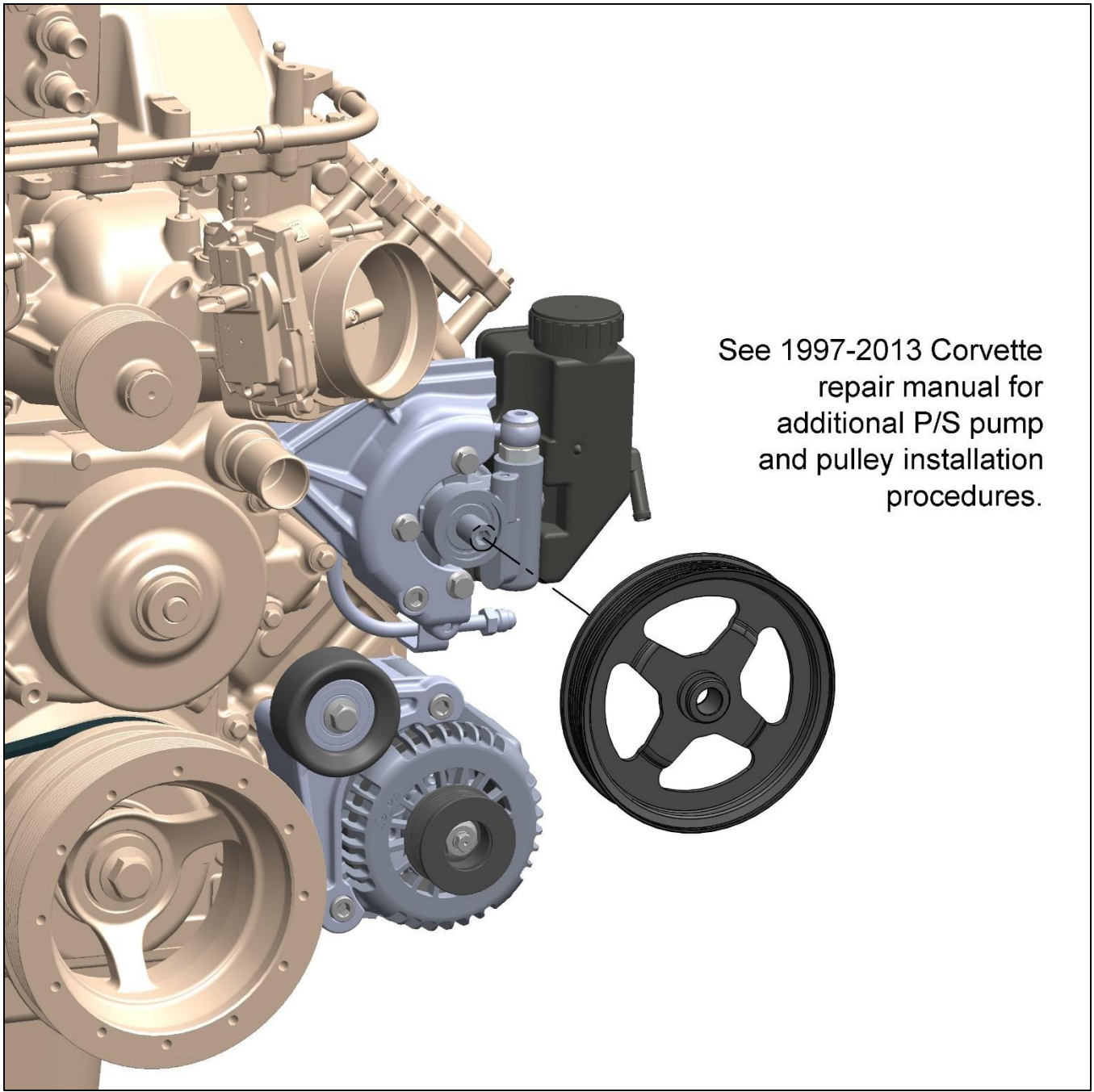

See 1997-2013 Corvette
repair manual for
additional P/S pump
and pulley installation
procedures.

The P/S pulley must be installed using an installation tool that can be rented at most auto parts stores. Incorrect installation of this pulley may damage the P/S pump internals. When installed, the pulley bore face should be flush with the end of the pump shaft.

Accessory Belt Installation:

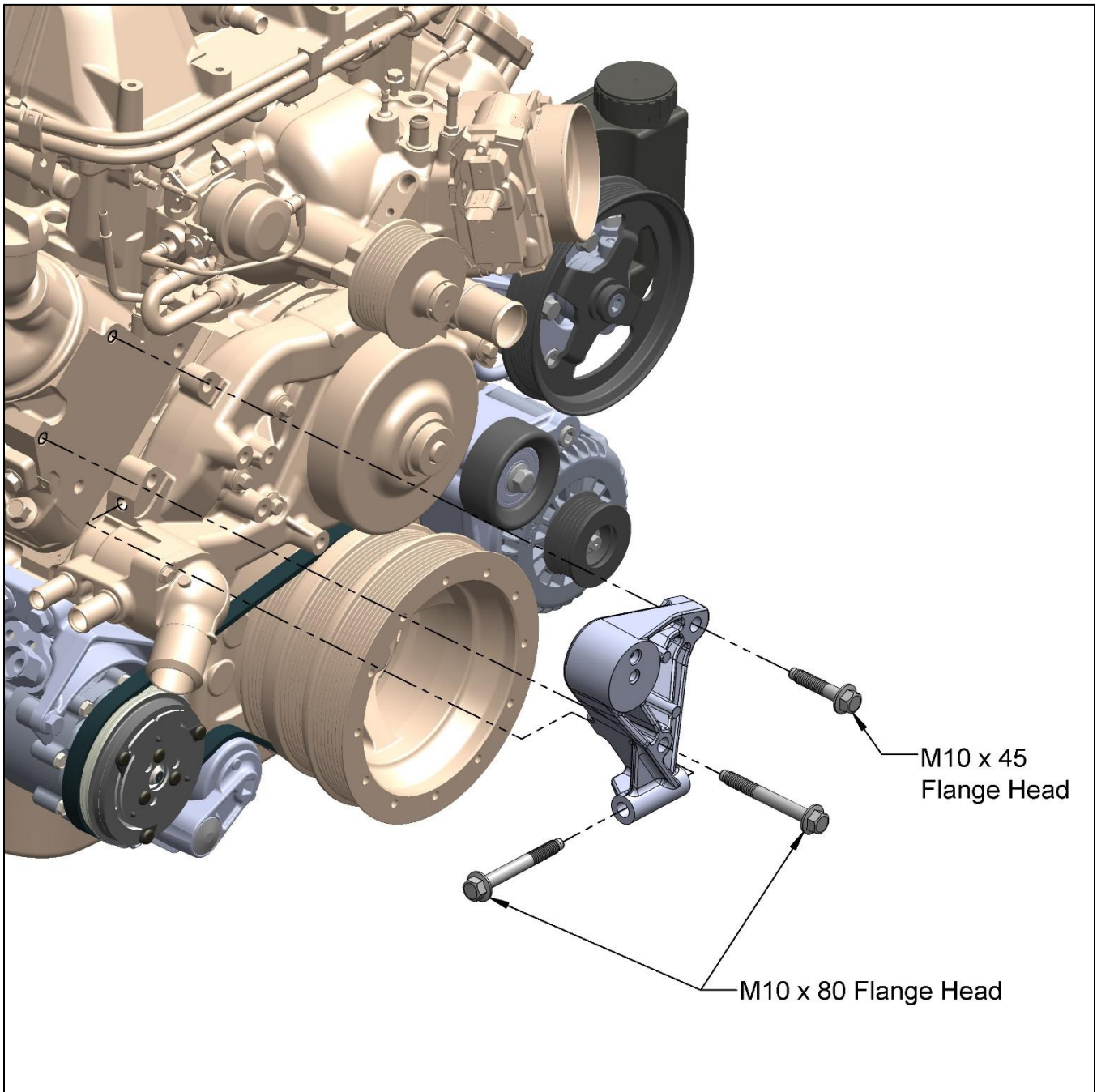

NOTE: Torque M10 bolts to 36 ft./lbs.

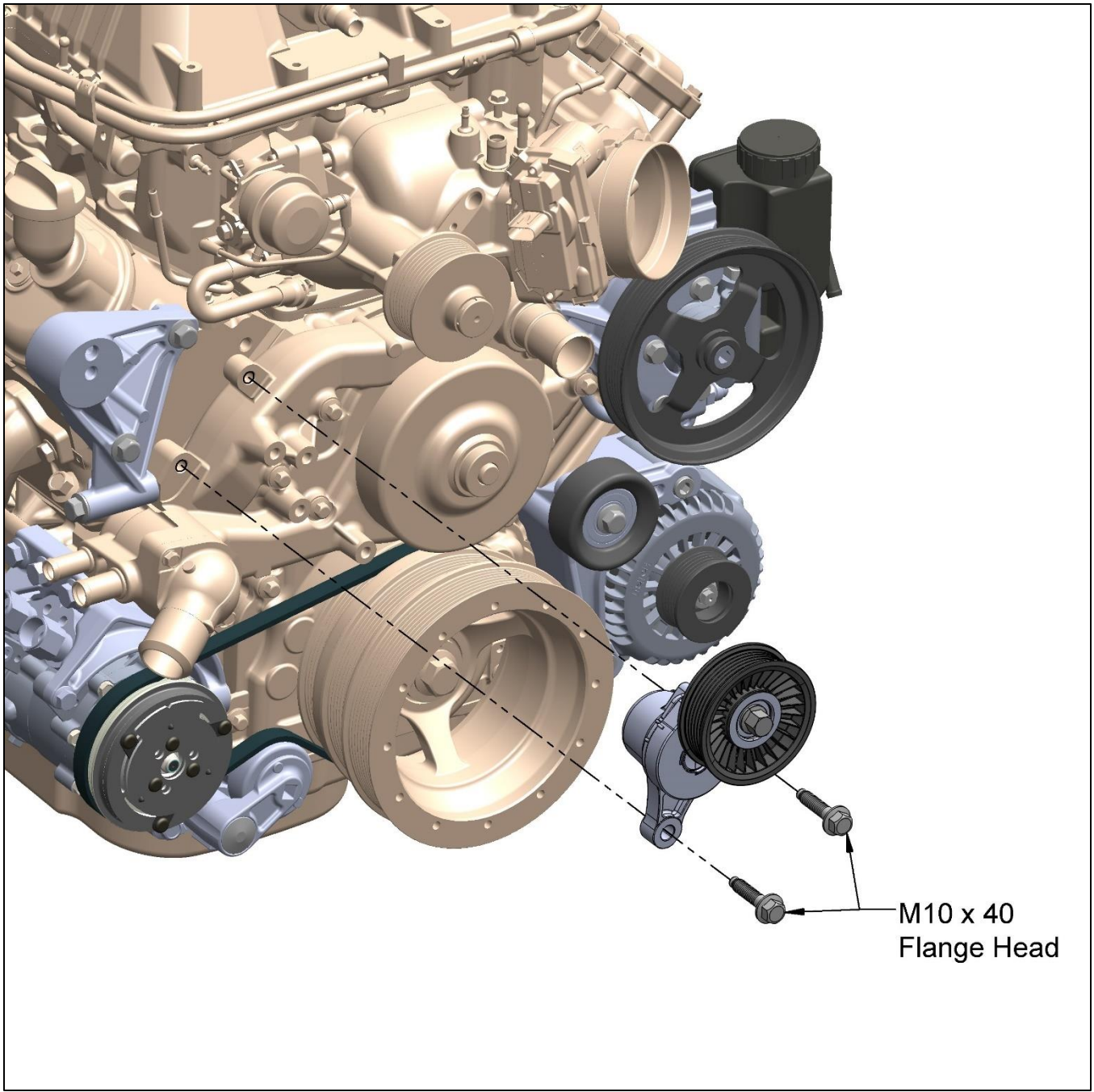

NOTE: Torque M10 bolts to 36 ft./lbs.

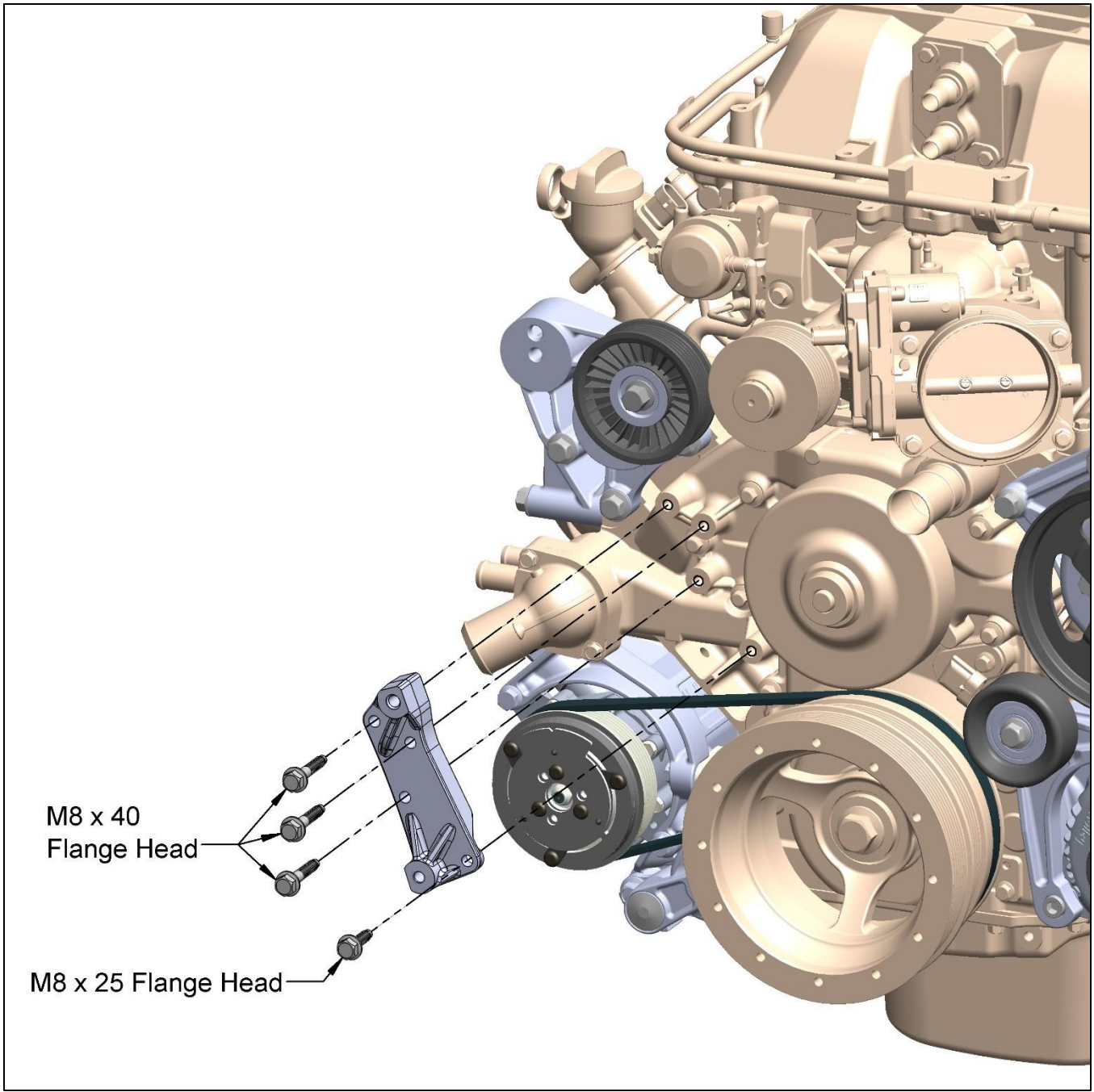

NOTE: Torque M10 bolts to 36 ft./lbs.

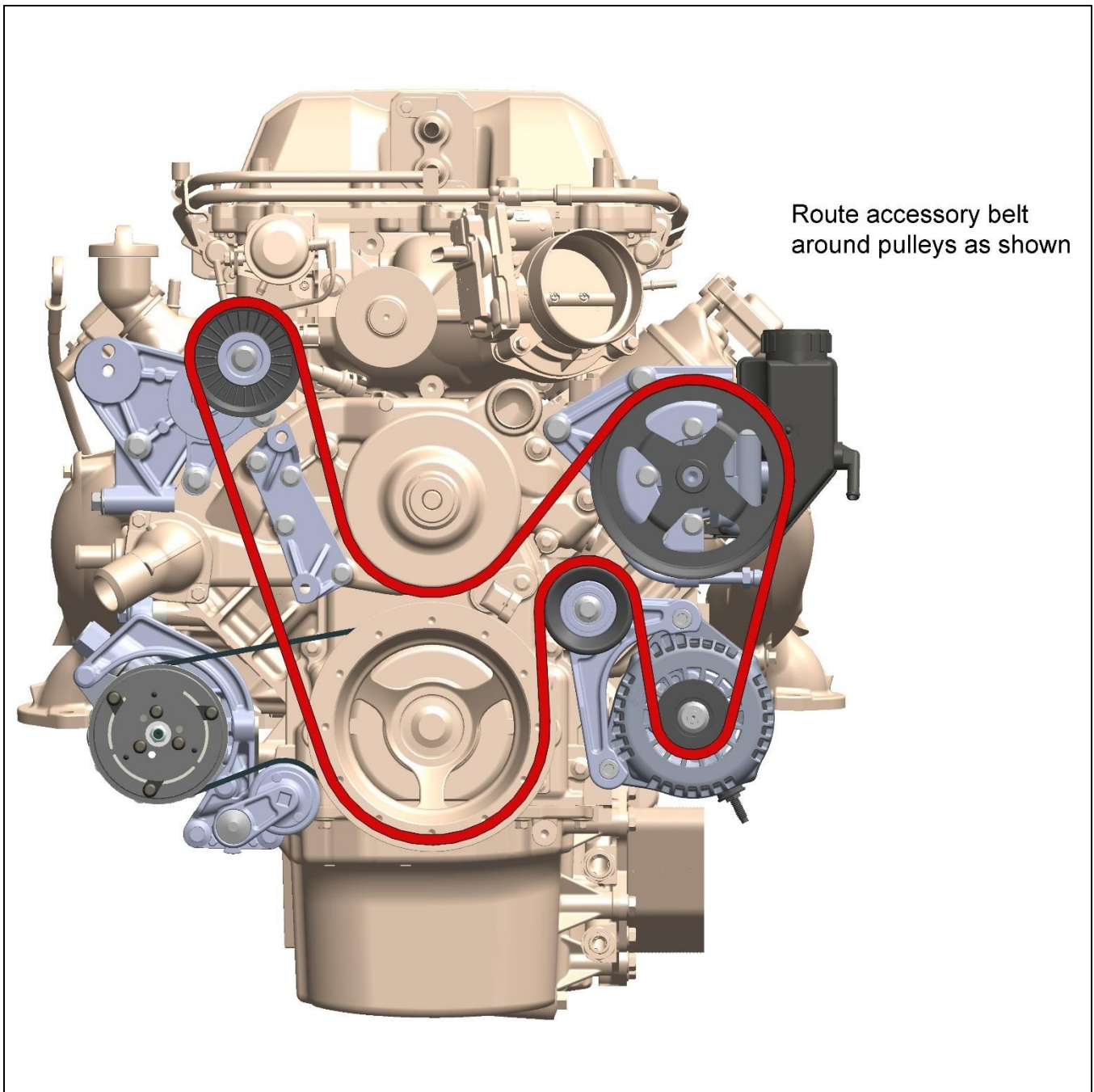

HELPFUL HINT: When installing the belt, route around all the pulleys except the water pump pulley. While fully rotating the tensioner arm, slip the belt on the smooth water pump pulley last.

Use serpentine belt supplied if using ALL included Holley accessories and supplemental parts.

SC Belt Installation:

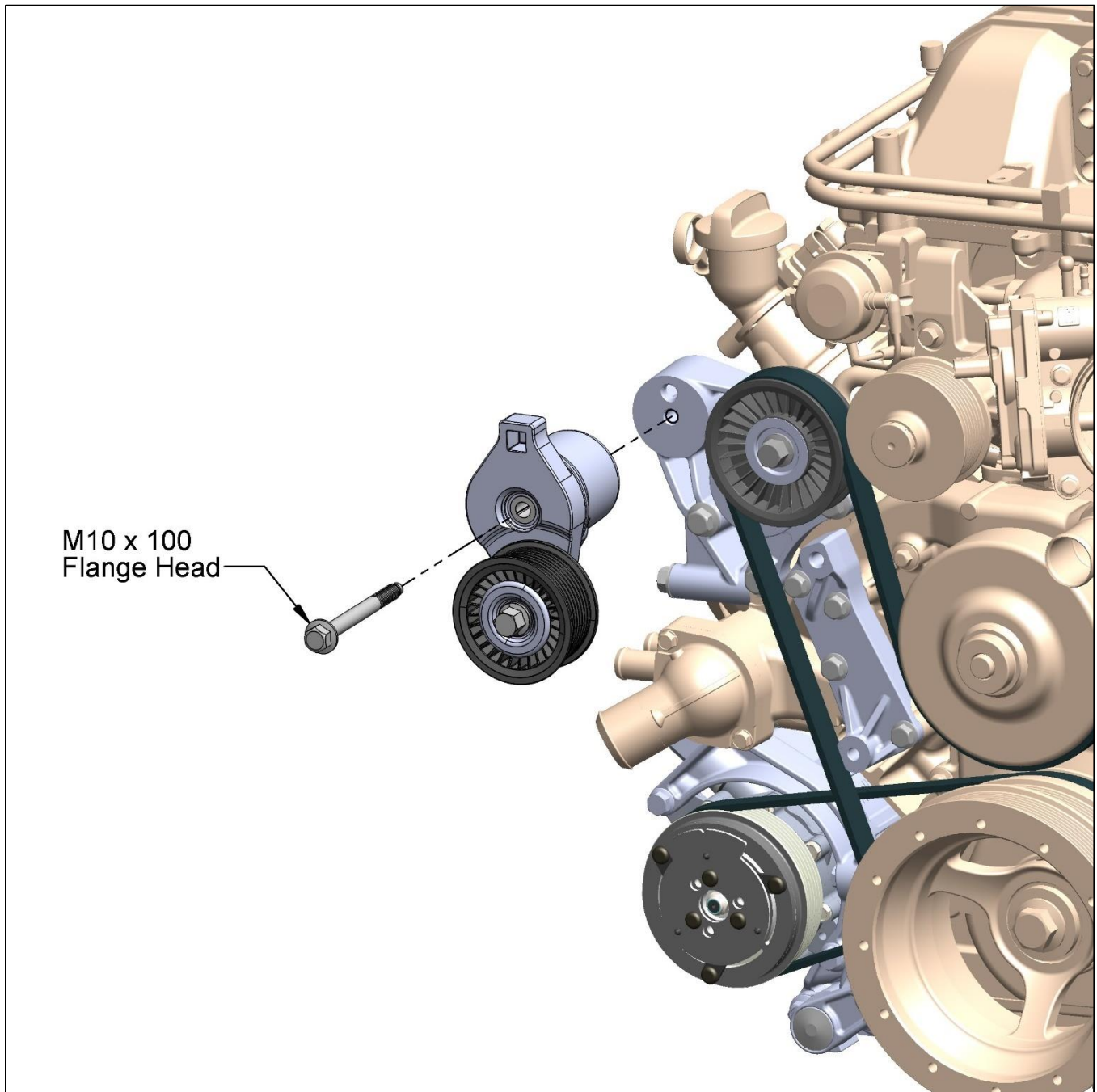

NOTE: Torque M10 bolt to 36 ft./lbs.

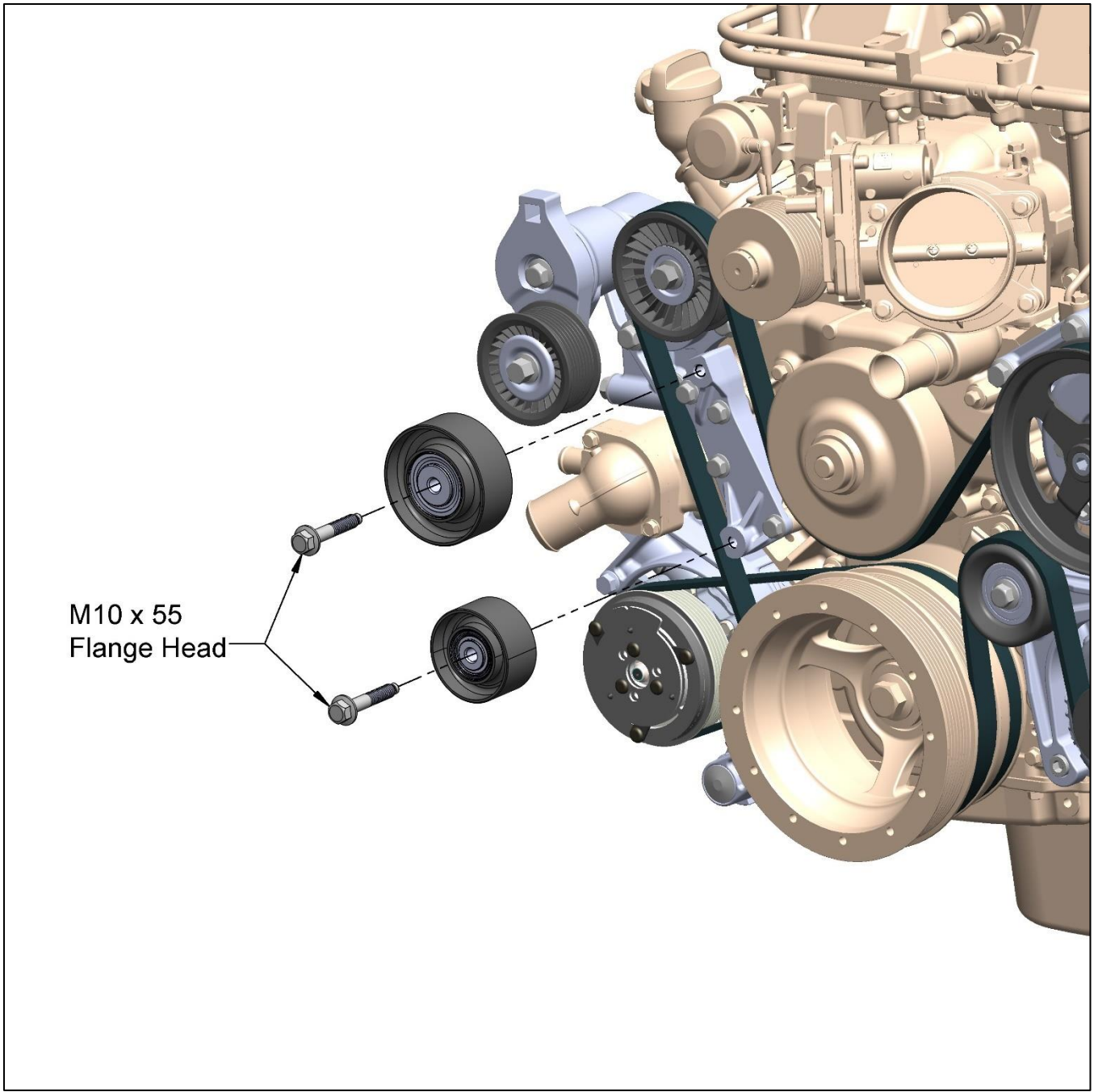

M10 x 55
Flange Head

NOTE: Torque M10 bolts to 36 ft./lbs.

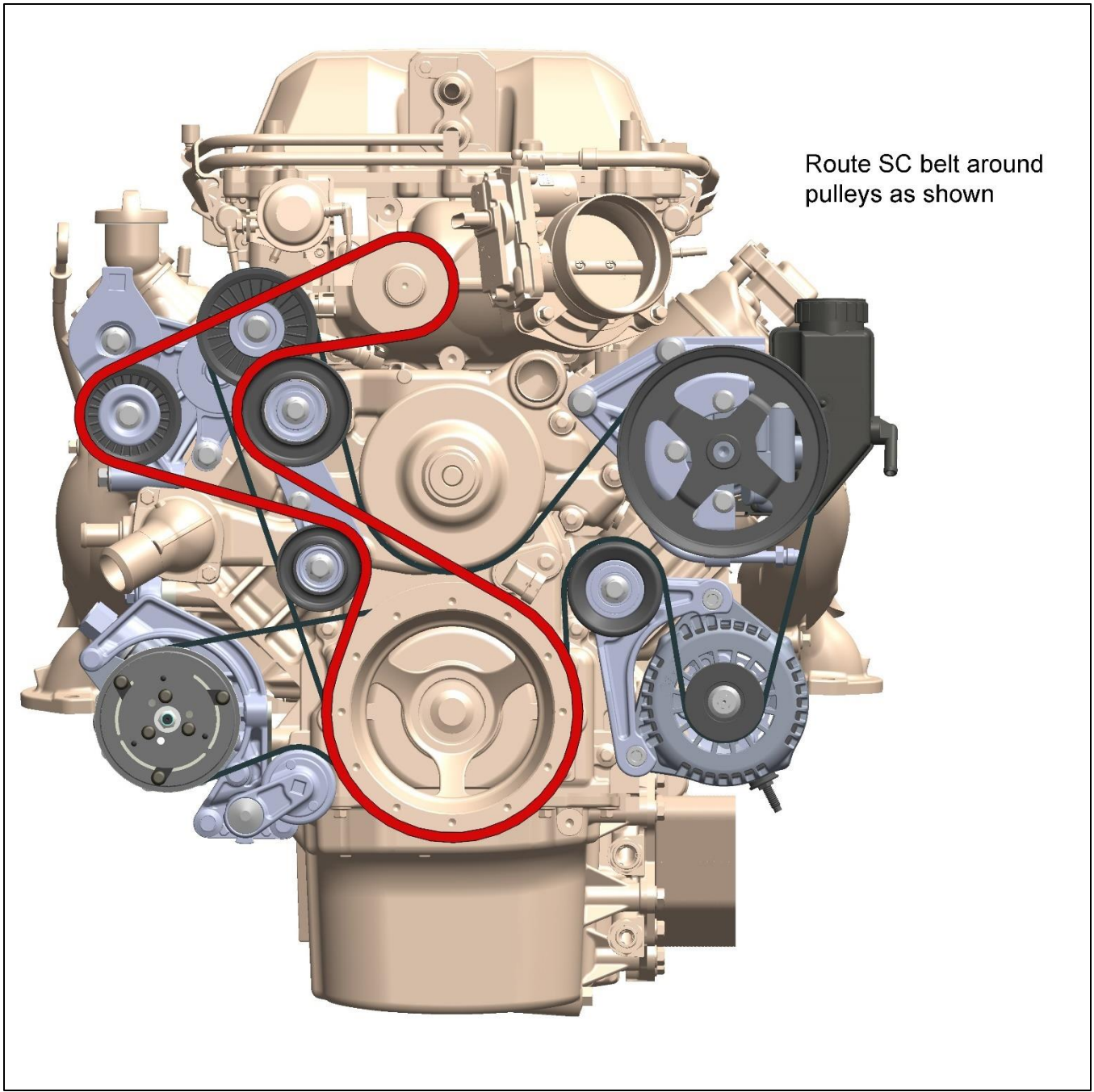

Route SC belt around pulleys as shown

HELPFUL HINT: When installing the belt, route around all the pulleys except the large idler pulley. While fully rotating the tensioner arm, slip the belt on the smooth idler pulley last.

Belt Length Calculation:

NOTE: If you are NOT using all the Holley accessories supplied, or have changed the original crank or any accessory's pulleys, you will have to measure to find the correct belt length.

To acquire this measurement, perform the following:

After all brackets and accessories are installed, route masking tape or string around the belt path. Leave the tensioner in the un-sprung position for this measurement. Mark or cut the tape/string to length and remove from the pulleys. Subtract 1 1/8" (28 mm) from the measured length to compensate for the un-sprung tensioner position. You will need to convert belt length to millimeters if measured in inches (inches X 25.4 = mm). Go to any auto parts store and ask for a 6PK0000 belt with the "0000" being the length in millimeters. For example, if you measured 2493 mm and then subtracted 28 mm, you would get 2465 mm, and the part number would be 6PK2465.

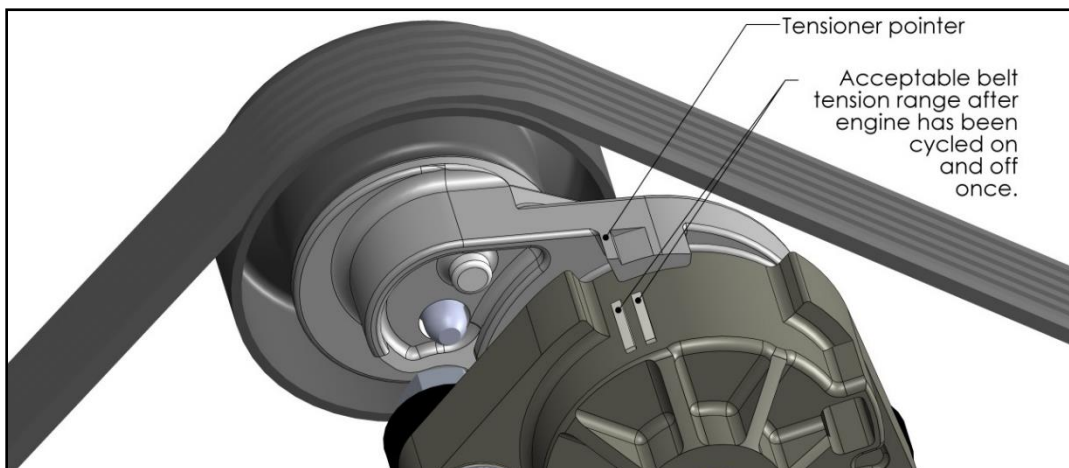

Technical Support: 1-866-464-6553

Holley® Performance Products, Inc.
1801 Russellville Road
Bowling Green, KY 42101

Technical Support: 1-866-464-6553
Phone: 1-270-781-9741
www.holley.com

© 2021 Holley Performance Products, Inc. All rights reserved. Tous Droits Réservés.

199R12099
Date: 3-11-21