

Holley® iNTECH

2005-2019 Nissan Frontier V6, 4.0L

2005-2012 Nissan Pathfinder

2005-2015 Nissan Xterra

Intech Cold Air Intake System

223-42

Installation Instructions

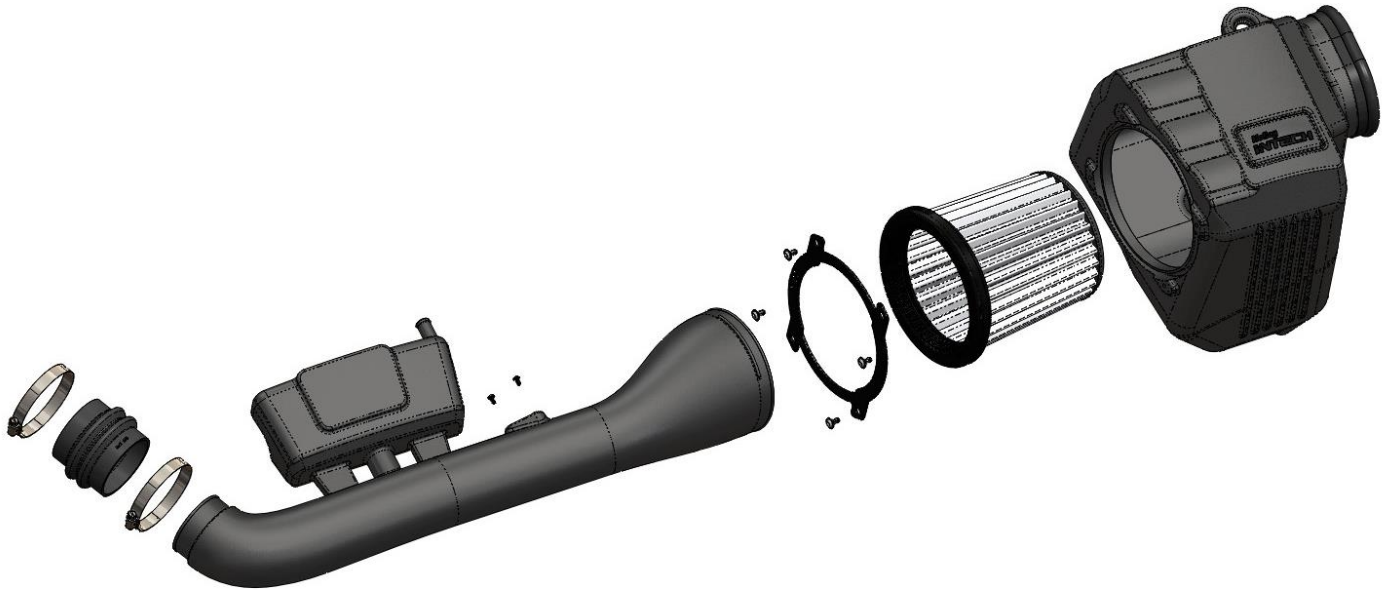

Thank you for making HOLLEY iNTECH COLD AIR INTAKES your choice in a high-performance air intake system. Extensive dyno/track testing has enabled HOLLEY to offer the most advanced design in sealed air intake systems. HOLLEY iNTECH's patented interface allows for an easy and seamless installation, moreover, results will show additional horsepower, reduced air intake temperature and improved performance. Proper installation and maintenance will ensure long life and maximum performance from your HOLLEY iNTECH COLD AIR INTAKE. Visit PATENTS.HOLLEY.COM for more information.

BEFORE STARTING:

Ensure that the engine is cold and has not been ran for a minimum of 2 hours prior to install.

INCLUDED HARDWARE:

P/N	Qty.	Description
80R158	1	Air Filter
223-42A	1	Tube
223-42H	1	Housing
61R1040	1	Coupling, Dbl Hump, Si,
557R14	2	Clamp, Worm-Drive SS
505R85	2	Screw, M4 x .07mm Phillips Head
505R115	4	M6 x 1.0mm x 12mm Blk-Ox SS
711R2	1	Trim Seal, U-Channel (16.5")
711R4	1	Retainer Ring
217R3	1	Fir Tree Cable Tie
99R10460	2	Decal, Intech 5" x 1.5", Die Cut Special

Check the hardware package. If anything is missing, please contact Technical Service at 1-866-464-6553 or 270-781-9741.

INSTALLATION:

1. Disconnect the negative cable from the vehicle battery.
2. Remove the (x2) screws securing the engine cover, then firmly lift to remove (**Figure 1**).
3. Disconnect the crankcase vent (CCV) hose from the backside of the factory intake tube (**Figure 1**).
4. Remove the (x2) screws securing the factory intake tube to the engine (**Figure 1**).
5. Disconnect the Mass Air Flow (MAF) sensor wiring harness from the MAF sensor (**Figure 1**).
6. Unclip the MAF wiring harness from the airbox assembly (**Figure 1**).
7. *If equipped, remove the vent hose from the back of the factory airbox.
8. Loosen the hose clamp securing the intake tube to the throttle body (**Figure 1**).
9. Remove the screw securing the factory housing in place & save for reuse (**Figure 1**).
10. Pull up firmly on the factory housing, and then remove the entire air intake assembly from the vehicle (**Figure 1**).

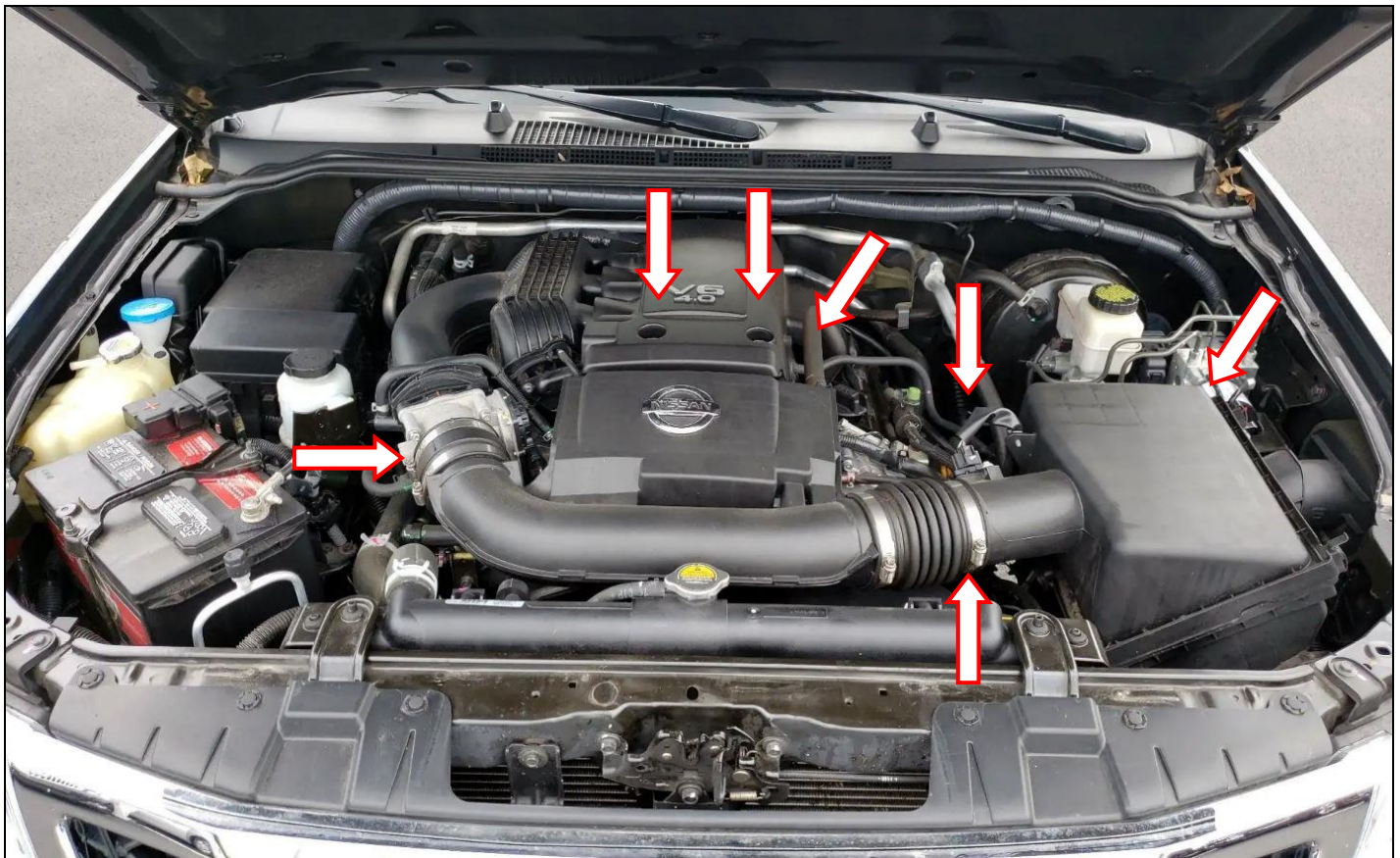

Figure 1

11. Remove the (x2) rubber grommets from the factory housing and replace on the iNTECH housing (**Figure 2**).
12. Remove the metal sleeve and rubber grommet from the lower half of the factory airbox and install in the iNTECH housing (**Figure 2**).
13. Install the provided rubber trim seal onto the iNTECH housing, pressing firmly and work all the way around the inlet opening.

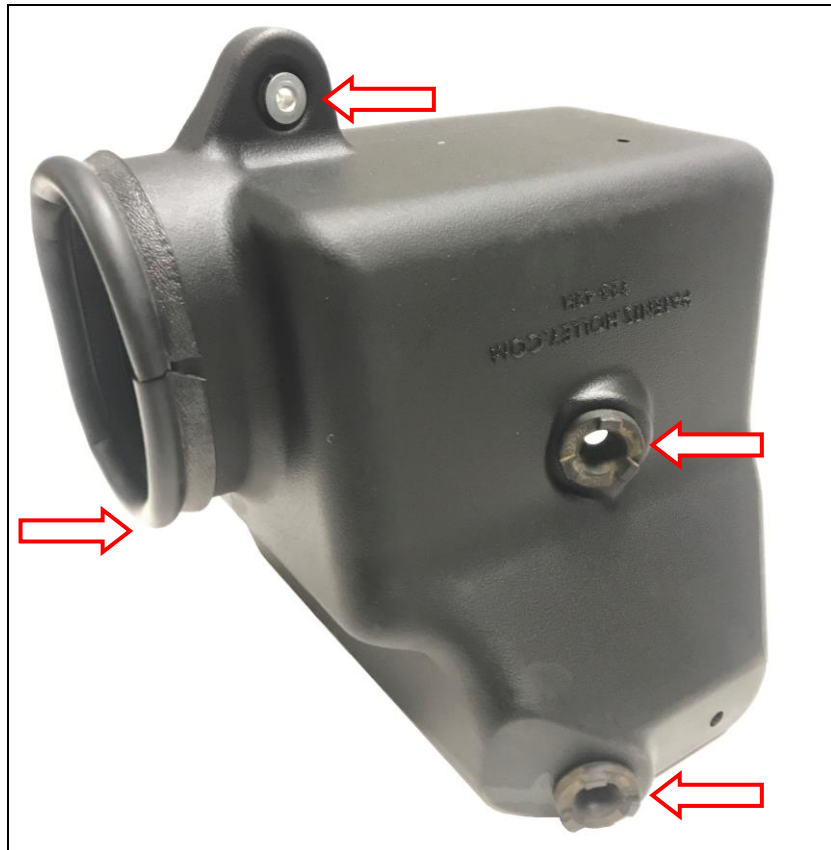

Figure 2

14. Using the (x2) supplied M4 screws, secure the MAF sensor onto the iNTECH intake tube and tighten (**Figure 3**).



Figure 3

15. Install the iNTECH housing into the vehicle by aligning the grommets with the studs, then firmly pressing down **(Figure 4)**.
16. Secure the iNTECH housing with the previously removed factory airbox screw, and then tighten **(Figure 4)**.
17. Install the iNTECH air filter into the iNTECH housing by firmly pressing into housing until filter is fully seated **(Figure 4)**.
18. Install the supplied silicone coupling on the throttle body and secure with a provided hose clamp, then tighten **(Figure 4)**.
19. Slip the provided metal ring over the large end of the iNTECH tube, then insert the tube into the air filter until you feel a 'lock' **(soap and water or equivalent will help with inserting the tube into the filter) (Figure 4)**.
20. Rotate and align the tube with the throttle body and coupling. Insert the tube into the coupling **(Figure 4)**.
21. Align the holes in the ring with the brass housing inserts and secure with the provided M6 screws **(Figure 4)**.
22. Install the remaining hose clamp over the coupling and tighten **(Figure 4)**.
23. Reconnect the MAF sensor wiring harness to the MAF sensor on the intake tube **(Figure 4)**.
24. Reconnect the CCV hose to the intake tube, sliding the factory metal spring clip over the fitting to secure **(Figure 4)**.

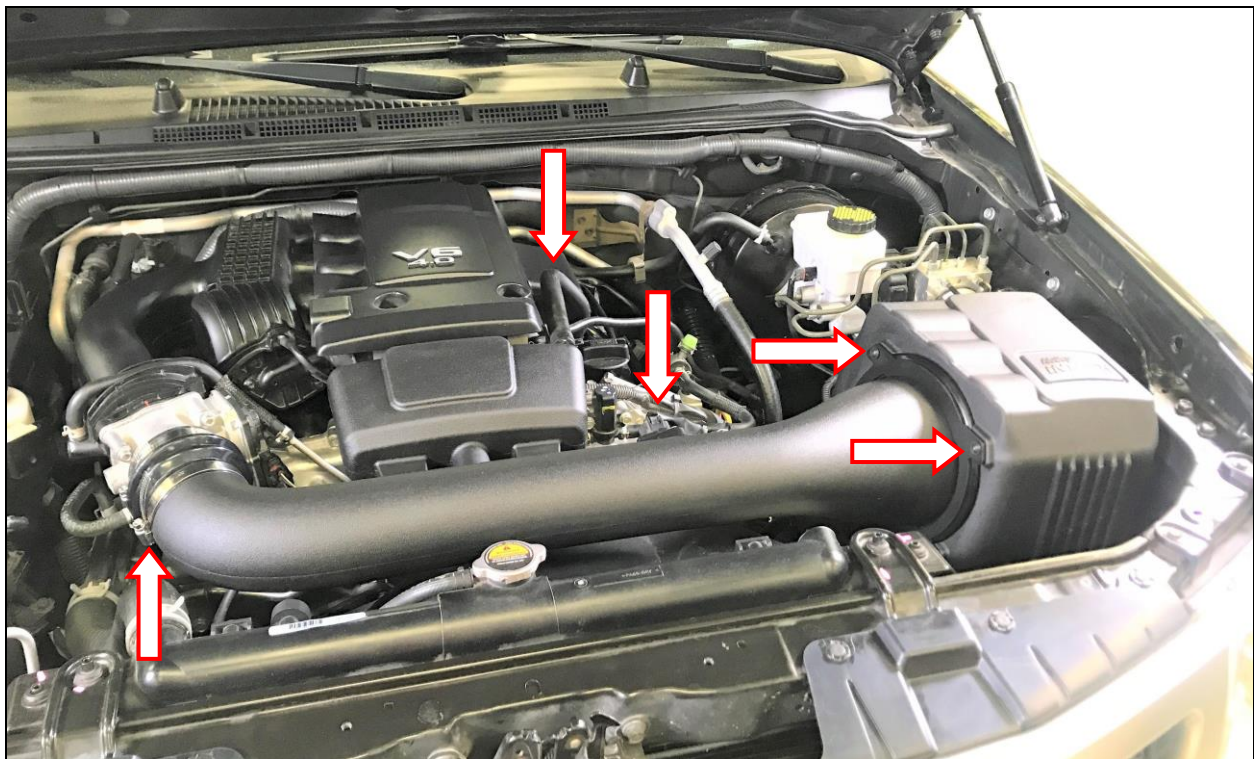

Figure 4

25. If removed in Step 7, reinstall the plastic clip on the vent hose into the hole on the back side of the iNTECH housing (Figure 5).

***NOTE: If factory plastic clip is damaged, a new cable tie has been provided.**

26. Connect the battery and re-check your work.

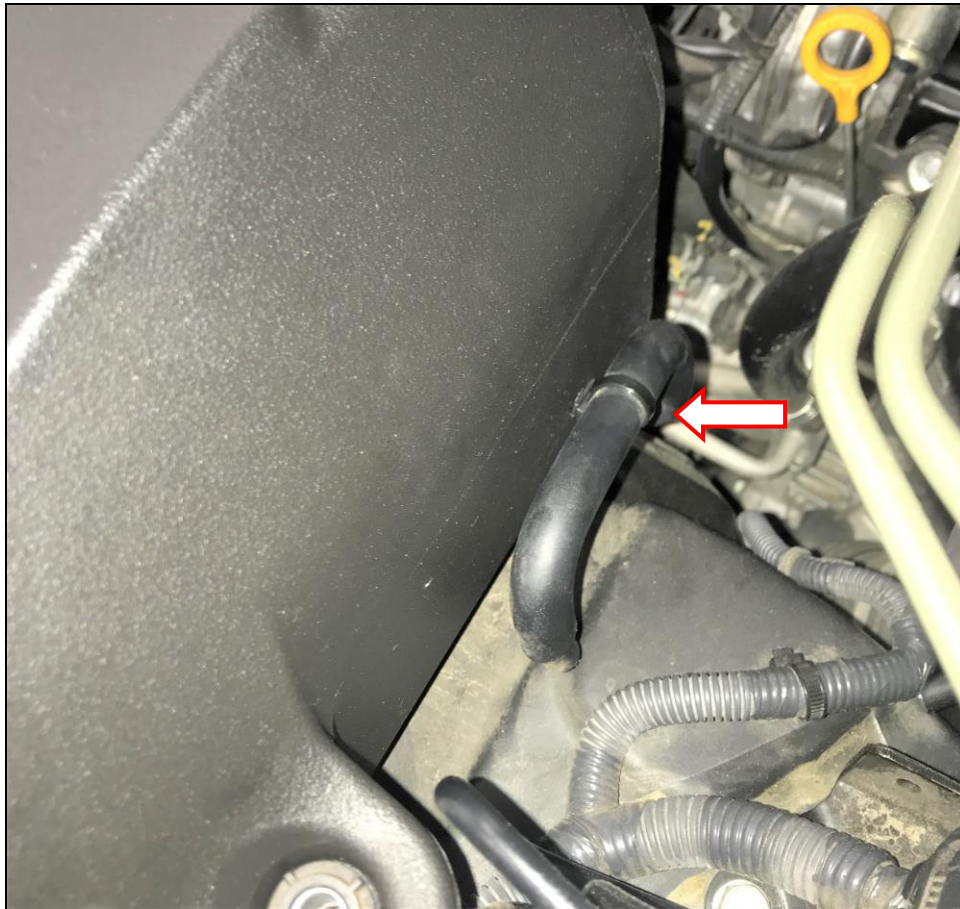

Figure 5

NOTE: Power gains may not be immediate. Accumulation of 200-500 miles and multiple key cycles may be needed for the vehicle to register optimum gains.

NOTE: After 150 miles, re-check and tighten all nuts, bolts, clamps and fittings.



This part is legal under the provisions of EPA's Tampering Policy dated November 23rd, 2020. The company has reasonable basis (test results) to verify that this product allows the vehicle to operate within legal emissions standards and is therefore legal to be sold for on-street use in all states that accept the legal provisions of the Clean Air Act and the EPA Tampering Policy. This product is NOT LEGAL FOR SALE OR USE IN THE STATE OF CALIFORNIA. Testing with the California Air Resources Board, in order to achieve 50-state compliance, is pending with CARB. Once testing is complete with California, and an E.O. number is issued, this product will be updated to 50-state legal status.

LIMITATION OF LIABILITY – DISCLAIMER:

The regulation of emissions production, noise levels, and safety standards is undertaken by the federal government, each of the fifty state legislatures, and by many local municipalities, towns, and counties.

HOLLEY INTECH makes no warranties of merchantability, of fitness for particular purpose, or that its products are approved for general use, or that its products comply with laws, regulations, or ordinances in the state where they may be sold to the ultimate purchaser, the consumer.

Unless expressly stated to the contrary in the catalog, instruction sheet; or price list, the entire risk as to the conformity of any company product in any such state and as to repair should the product prove to be defective or non-conforming, is on the retail purchaser, the buyer, the ultimate consumer, of such product and it is not upon the seller, distributor, or manufacturer.

In this connection, the retail purchaser, the buyer, the ultimate consumer assumes the burden of the entire cost of any and all necessary service, alterations, or repair.

THE FOREGOING STATEMENT LIMITS THE LIABILITY OF THE MANUFACTURER.

California vehicle code, sections 27156 and 38391, prohibits the advertising, offering for sale, or installation of any device, which modifies a vehicle's emission control system, unless exempted, unless otherwise noted. HOLLEY INTECH that has not received an Executive Order (E.O.) exemption from these code sections are not legal for sale or use in California on vehicles originally equipped with catalytic converters, except for racing vehicles, which may never be driven upon a highway. Check with your local authorities to determine if these cold air intakes are legal for use in your particular area.

© 2021 Intech, Inc. All rights reserved. Tous Droits Réservés.

199R12151

Revision Date: 11-12-21