

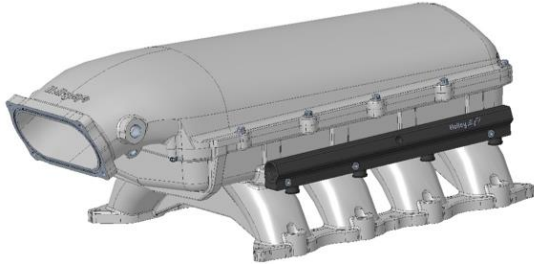

Holley Hi-Ram & Ultra Lo-Ram Intake Manifold Kits for 2011-2022 Ford 5.0L Coyote Engines

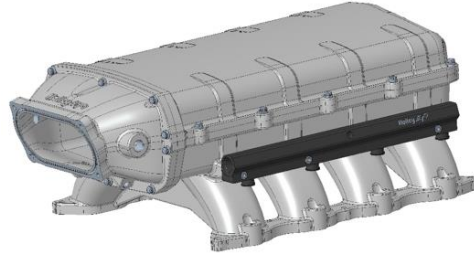

300-910
Hi-Ram Manifold Kit



300-911
Ultra Lo-Ram Manifold Kit for 2007-14
GT500 throttles, Oval

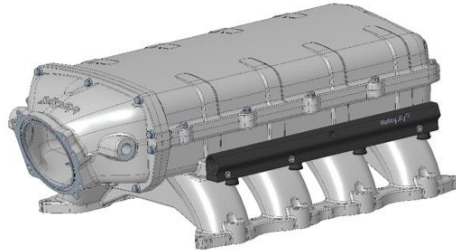

300-912
Ultra Lo-Ram Manifold Kit for 2015-20 GT350 or
2019-22 GT500 throttles, Round

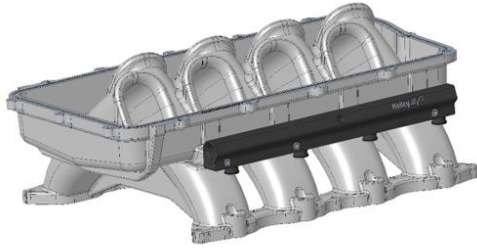

300-920
Hi-Ram Base and Fuel Rail Kit

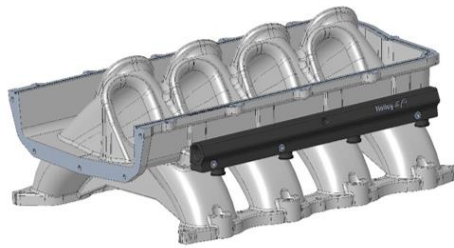

300-921
Ultra Lo-Ram Base and Fuel Rail Kit

Holley P/N	Description
300-910	Manifold Kit, Hi-Ram for 2007-2014 GT500 Throttle, Oval
300-910BK	Manifold Kit, Hi-Ram for 2007-2014 GT500 Throttle, Black Finish, Oval
300-911	Manifold Kit, Ultra Lo-Ram for 2007-2014 GT500 Throttle, Oval
300-911BK	Manifold Kit, Ultra Lo-Ram for 2007-2014 GT500 Throttle, Black Finish, Oval
300-912	Manifold Kit, Ultra Lo-Ram for 2015-2020 GT350 or 2019-2022 GT500 Throttle, Round
300-912BK	Manifold Kit, Ultra Lo-Ram for 2015-2020 GT350 or 2019-2022 GT500 Throttle, Black Finish, Round
300-920	Base Manifold Only Kit, Hi-Ram
300-920BK	Base Manifold Only Kit, Hi-Ram, Black Finish
300-921	Base Manifold Only Kit, Ultra Lo-Ram
300-921BK	Base Manifold Only Kit, Ultra Lo-Ram, Black Finish
300-922	Plenum Lid Kit, Coyote Hi-Ram
300-922BK	Plenum Lid Kit, Coyote Hi-Ram, Black Finish
300-923	Plenum Lid Kit, Coyote Ultra Lo-Ram
300-923BK	Plenum Lid Kit, Coyote Ultra Lo-Ram, Black Finish
300-924	Throttle Flange Kit, Coyote Ultra Lo-Ram for 2007-2014 GT500, Oval
300-924BK	Throttle Flange Kit, Coyote Ultra Lo-Ram for 2007-2014 GT500, Black Finish, Oval
300-925	Throttle Flange Kit, Coyote Ultra Lo-Ram for 2019-2022 GT500 or 2015-2020 GT350, Round
300-925BK	Throttle Flange Kit, Coyote Ultra Lo-Ram for 2019-2022 GT500 or 2015-2020 GT350, Black Finish, Round

Applications:

These manifolds are designed for 2011-2023 Ford 5.0L high performance engines with cylinder heads that have an OEM type mounting pattern and port dimensions. These kits include fuel rails for use with OEM type fuel injectors and will not accept most stock components or hardware. Also included are O-ring seals for each port. The available flanges for the throttle valves are shown below.

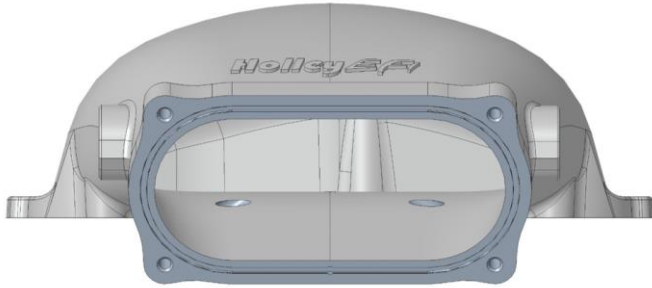

300-910 and 300-922 are designed to work with Ford GT500 (2007-2014) type throttles – throttle opening is 150mm x 66mm

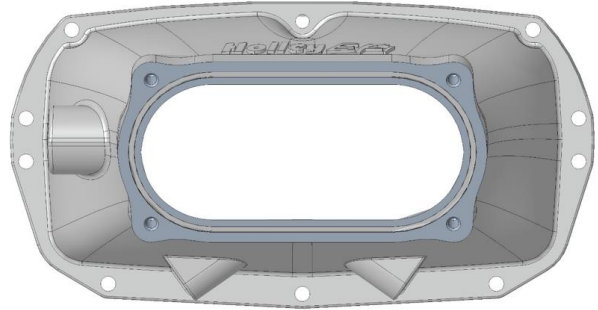

300-911 and 300-924 are designed to work with Ford GT500 (2007-2014) type throttles – throttle opening is 150mm x 66mm

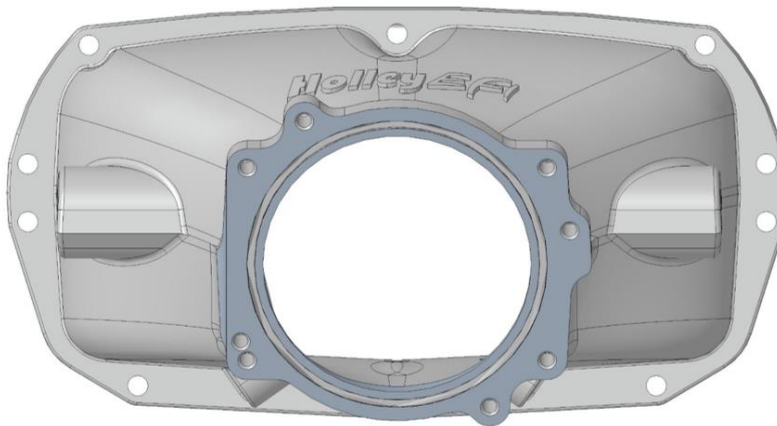

300-912 and 300-925 are designed to work with any of these throttle types – throttle opening is 93mm in diameter:

- Ford GT350 (2015-2020)
- Ford GT500 (2019-2022)
- Ford Mustang GT (2011-2022), using optional adapter, Holley P/N 717-18
- GM LS 4 bolt

Emissions Equipment:

These manifolds do not accept any emission-control devices and are not legal for use with motor vehicles that include pollution controlling equipment.

Dimensions:

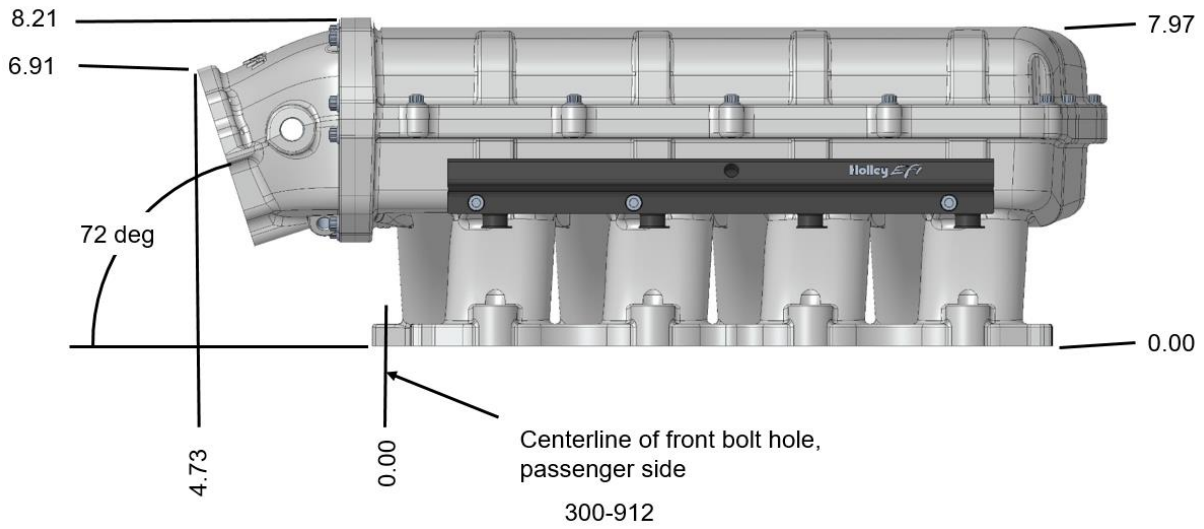
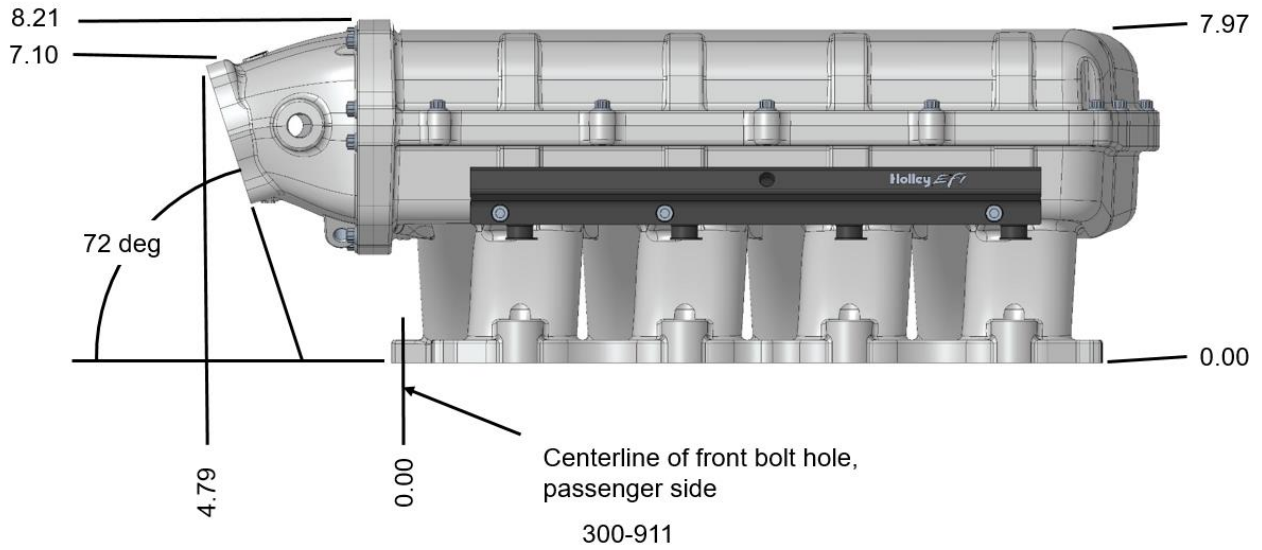
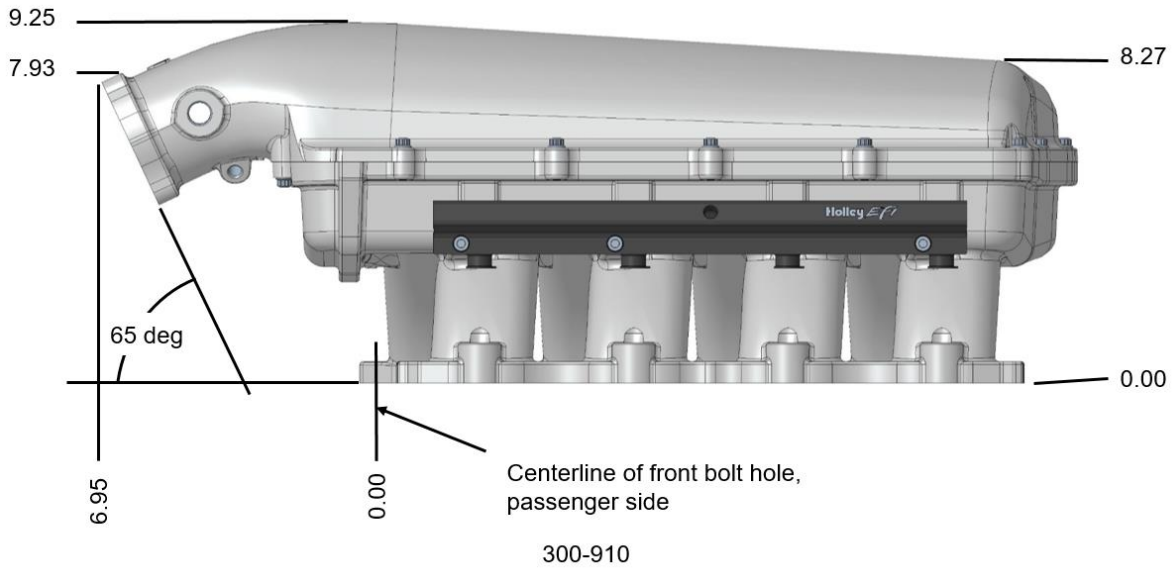

Kit Contents:

Qty.	Description
300-910 Hi-Ram Intake Manifold Kit for Top Feed	
1	300-920 Intake Manifold Base & Fuel Rail Kit
1	300-922 Hi-Ram Plenum Kit

300-920 Hi-Ram Intake Manifold Base Kit for Top Feed	
1	Hi-Ram Intake Manifold Base
1	534-320 Fuel Rail Kit
1	300-926 Manifold Installation Kit
1	508-55 Seal Kit
1	300-927 Plenum Installation Kit

300-921 Ultra Lo-Ram Intake Manifold Base Kit	
1	Front feed Intake Manifold Base
1	534-320 Fuel Rail Kit
1	300-926 Manifold Installation Kit
1	508-55 Seal Kit
1	300-927 Plenum Installation Kit

300-926 Base Manifold Installation Kit	
10	Stud, M6 x 38MM
10	Washer, M6 Flat
10	Nut, M6 Flanged

300-927 Plenum Lid Installation Kit	
22	M6 x 20mm 12 Point Cap Screw
2	1/8-27 NPT Plug
2	3/8-18 NPT Plug

Qty.	Description
300-911 Ultra Lo-Ram Intake Manifold Kit, Oval Throttle	
1	300-921 Ultra Lo-Ram Intake Manifold Base & Fuel Rail Kit
1	300-923 Ultra Lo-Ram Plenum Top Kit
1	300-924 Ultra Lo-Ram Throttle Flange Kit for Oval throttle

300-912 Ultra Lo-Ram Intake Manifold Kit, Round Throttle	
1	300-921 Intake Manifold Base & Fuel Rail Kit
1	300-923 Ultra Lo-Ram Plenum Top Kit
1	300-924 Ultra Lo-Ram Thr. Flg. Kit for Round throttle

300-922 Plenum Lid Kit for Hi-Ram	
1	Hi-Ram Plenum Lid

300-923 Plenum Lid Kit for Ultra Lo-Ram	
1	Ultra Lo-Ram Plenum Lid

300-924 Throttle Flange Kit	
1	Ultra Lo-Ram Throttle Flange for 2007-2014 GT500 throttle

300-925 Throttle Flange Kit	
1	Ultra Lo-Ram Thr. Flg. for 2015-2020 GT350 or 2019-2022 GT500 throttle

508-55 Seal Kit	
8	O-rings for port seals
1	O-ring cord for plenum top seal

534-320 Fuel Rail Kit	
2	Fuel Rails
6	Screws, M6 x 30mm Socket Head Cap
2	Plug, 1/8-27 NPT

NOTE: Before assembly or installation of your Hi-Ram intake manifold components, please ensure that they are clean and free of contaminants or debris.

Assembly of the Hi-Ram Plenum Lid:

- Before installing the plenum top, the O-ring cord will need to be cut to length and glued together.
 - Lay the O-ring cord into the groove on the plenum flange of the base manifold with the free ends overlapped.
 - Mark the position of the cut to be made across both O-ring cord ends.
 - Lay the O-ring cord on a flat surface with the ends overlapped and the marks aligned as they were when the marks were made.
 - With a sharp razor blade, cut through both ends of the O-ring cord at the mark simultaneously.
 - With a drop of super glue (Cyanoacrylate), bond the ends of the O-ring cord together. The glued joint should be smooth, not offset or kinked.
 - To ensure sealing at the glued joint, apply a thin film of silicone sealer around the O-ring at the glued joint, allowing the silicone to partially cure before installation of the joined O-ring cord in the groove.
- Install the glued O-ring cord in the groove on the base intake manifold plenum top mounting flange.
- Use the M6 x 20mm screws to attach the plenum lid to the base manifold. Apply a drop of oil to the threads of each screw before assembling finger tight. Using the sequence shown gently tighten the screws evenly until the O-ring seal is compressed. Torque the screws in two stages, first to 75 inch-pounds and then to 130 inch-pounds.

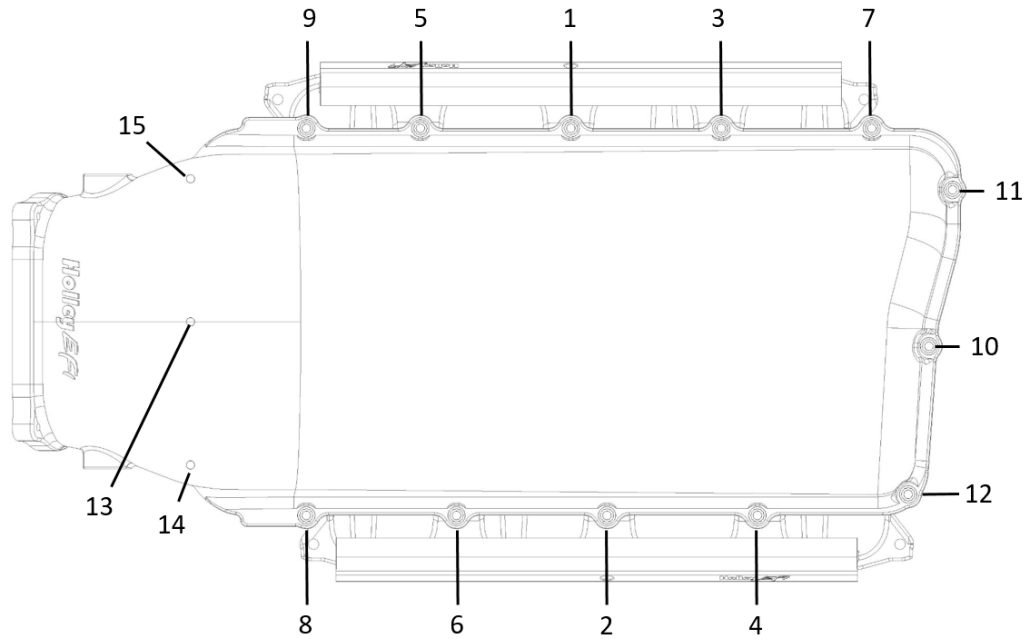

Plenum Top Torque Sequence for 300-910

Assembly of the Hi-Ram Plenum Lid and Throttle Body Flange:

1. Install the supplied O-ring cord in the groove on the base manifold plenum flange so that the ends of the O-ring cord extend out of the groove at the throttle body flange.
2. Use the M6 x 20mm screws to attach the plenum lid to the base manifold. Apply a drop of oil to the threads of each screw before assembling finger tight. Using the sequence shown gently tighten the screws evenly until the O-ring seal is compressed.

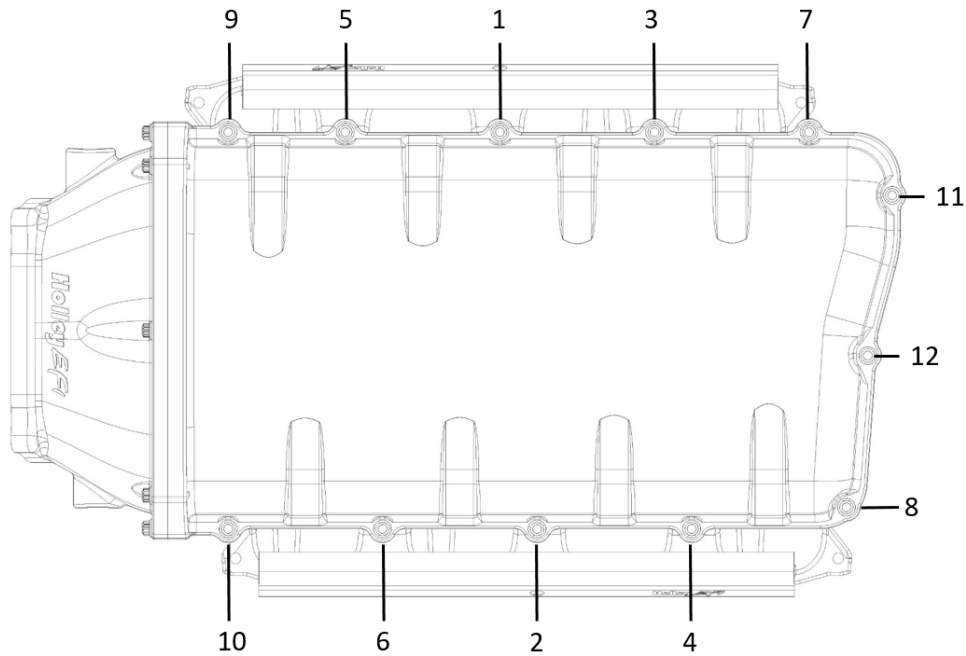

Plenum Top Torque Sequence for 300-911, 300-912

3. Using a sharp razor blade, trim-off the two ends of the O-ring cord flush to the throttle body flange on the base intake manifold. Once the O-ring cord ends are trimmed, loosen the plenum top fasteners

enough that the plenum top throttle body flange can be aligned to the base intake manifold throttle body flange by doing a preliminary install of the throttle body flange.

4. Make sure the O-ring seal is not installed in the throttle body flange during the preliminary installation of this part. Using the M6 x 30mm screws, attach the throttle body flange to the flange formed by the base manifold and plenum lid. Lightly tighten the throttle flange until the plenum top and base manifold are aligned as one flange.
5. Tighten the plenum lid so that its position will be retained, and then remove the throttle body flange.
6. The supplied O-ring cord, to seal the throttle body flange, needs to be cut to length and the ends glued together.
 - Insert the O-ring cord into the groove on the mounting flange of the throttle body flange with the free ends overlapped.
 - Mark the position of the cut to be made across both O-ring cord ends.
 - Lay the O-ring cord on a flat surface with the ends overlapped and the marks aligned as they were when the marks were made.
 - With a sharp razor blade cut through both ends of the O-ring cord at the marks simultaneously.
 - With a drop of super glue (Cyanoacrylate), bond the ends of the O-ring cord together. The glued joint should be smooth, not offset or kinked
 - To ensure sealing at the glued joint, apply a thin film of silicone sealer around the O-ring cord at the glued joint, allowing the silicone to partially cure before installation of the joined O-ring cord in the groove.
7. Install the glued O-ring cord in the groove on the throttle body flange. The O-ring groove in the throttle body flange is of a dove-tail design. Be careful when inserting the O-ring into the groove to not cut the O-ring on the leading edges of the groove. Stretching length-ways the section of the O-ring being inserted into the groove will shrink the cross-section of the O-ring and allow it to more easily slip into the groove. The joined area of the O-ring should be positioned in the groove to be opposite of the area where fluid is most likely to gather in a pool at the flange.
8. Before installing the throttle body flange, apply a dab of silicone sealer on the mating flange (2 places), where O-ring seal groove for the plenum top mounting flange intersects throttle body flange. Using the supplied M6 x 30 with a drop of oil applied to the threads, assemble the throttle body flange using the sequence shown below. Gently tighten the screws for the throttle body flange evenly until the O-ring seal is fully compressed and the adapter is seated on the mating flange. Torque the screws in two stages, first to 75 inch-pounds and then to 130 inch-pounds.

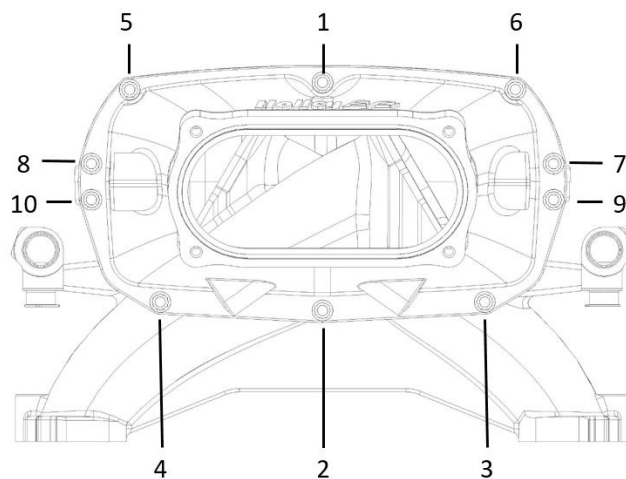

Throttle Body Flange Torque Sequence

300-911 & 300-912

Installation of the Fuel Injectors and Fuel Rails:

1. Apply a silicone lubricant to the O-rings of each fuel injector.
2. Insert each fuel injector into the intake manifold.
3. Assemble each fuel rail to the fuel injectors. Orient the injectors as shown and use assembly clips (Ford 4F2Z-9C995-AA) to hold this position.
4. Using the M6 x 30 screws, attach the fuel rails to the bosses on the intake manifold. Torque the screws in two stages, first to 75 inch-pounds and then to 130 inch-pounds.

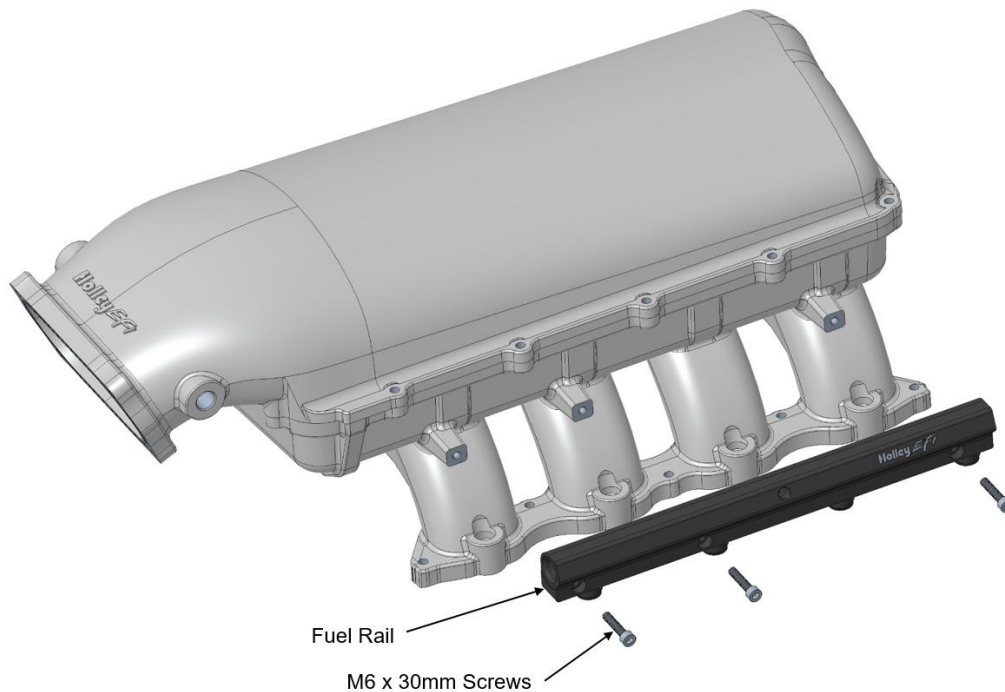

5. Each fuel rail has a 1/8-27 NPT port to allow use of a fuel pressure gauge. If these ports are not used, be certain that they are plugged and sealed. Port plugs are provided.

Installation of the Intake Manifold to the Engine:

1. Remove the water outlet from the engine. Then, remove the pressed-in tube from the water outlet. Tap the hole for the tube in the water outlet to 1/8-27 NPT. Assemble a 45 degree 1/8-27 to 1/4 inch hose barb into the water outlet oriented so that it clears the intake manifold. See images below.

Another option is to use a pipe or deep socket to bend the tube until clearance is provided.

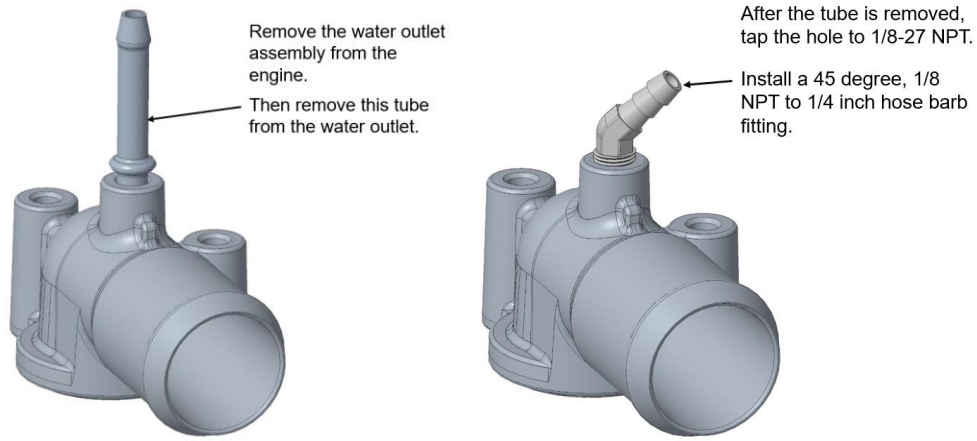

2. If you are installing a 300-911 Ultra Lo-Ram manifold, the coolant tube shown below will interfere with some throttle valves. Holley offers 300-913, a replacement coolant tube that clears these throttle valves. See images below.

Another option is to bend the OEM tube until clearance is provided to your throttle valve and linkage.

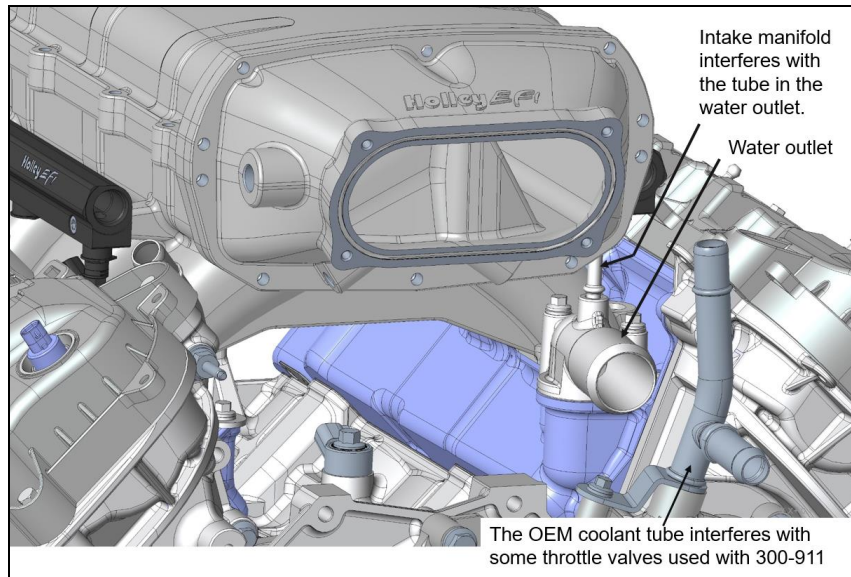

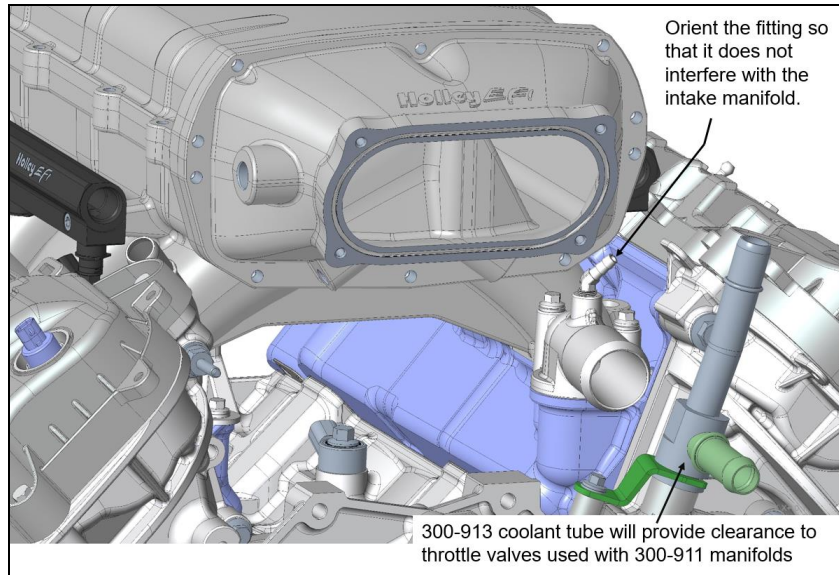

3. Apply a drop of oil to the threads of the studs provided in 300-926. Thread the studs into mounting holes of the cylinder heads.
4. Apply a silicone lubricant to each O-ring for the port seals. Gently press each O-ring into the grooves that surround each port of the manifold.
5. Assemble the intake manifold to the engine, using the washers and nuts provided.
6. In several stages, tighten the nuts using the sequence shown until the O-rings are completely compressed. Torque the nuts in two stages, first to 75 inch-pounds and then to 130 inch-pounds.

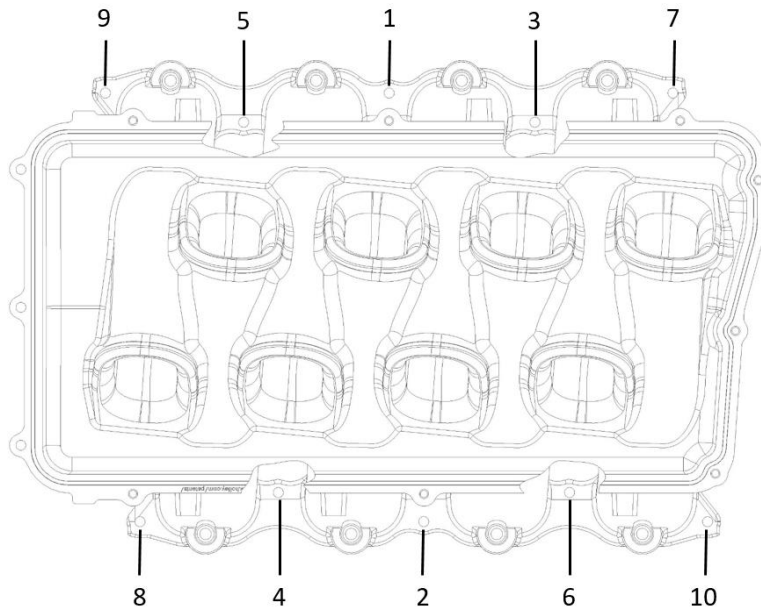

Accessories for Coyote Hi-Ram & Ultra Lo-Ram that are available separately:

P/N	Description
717-18	Throttle Adapter, 80mm throttle to 87mm flange
534-321	Fuel Rail 180 degree turn
300-913	Coolant Tube Assembly (for clearance to some throttles used with 300-911)

Service Parts for Coyote Hi-Ram & Ultra Lo-Ram that are available separately:

P/N	Description
300-926	Hardware kit for manifold base installation (silver)
300-926BK	Hardware kit for manifold base installation (black)
300-927	Hardware kit for plenum installation (silver)
300-927BK	Hardware kit for plenum installation (black)
508-55	Seal Kit
54-320	Fuel Rail Kit

**Holley Technical Support:
1-866-464-6553**

© 2022 Holley Performance Products, Inc. All rights reserved. Tous Droits Réservés

**199R12270
Revision Date: 3-23-23**