



# Holley Fuel Rails for OE, Naturally Aspirated 5.7L, 6.1L, and 6.4L HEMI engines

## APPLICATIONS:

**P/N 534-284** – Fits factory naturally aspirated 5.7L, 6.1L, and 6.4L HEMI engines.

- Fuel rails are machined to accept large -8 (3/4 -16) O-ring fittings (sold separately)
- Brackets are included for both factory length injectors (48.65mm) and long length (60.65mm) injectors, including performance EV1 style injectors.

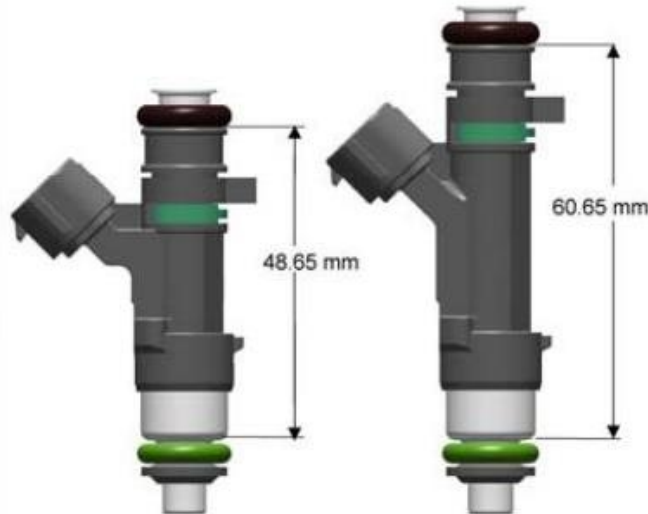

## OPTIONAL ACCESSORIES:

**P/N 534-211** - Adapter kit, required when directly connecting Holley fuel rails to factory fuel line quick-connect. Includes (x1) 3/4-16 O-ring port plug and (x1) -6 to quick connect adapter.

## SPECIAL TOOL REQUIRED:

3/8" Quick-Connect Release Tool to disconnect the factory fuel line (these are inexpensive and available at the local auto parts store).

## WARNINGS:

- Installation should be performed by a qualified mechanic.
- Read all instructions and warnings before beginning.
- Installation of this product involves handling of gasoline.
- Make certain there are no open flames in the area.
- Use eye protection during installation to protect against gasoline spray.

**NOTE:** System fuel pressure must be relieved before proceeding with disassembly. Refer to the vehicle service manual for procedures and precautions.

## INSTALLATION INSTRUCTIONS:

1. After the engine has cooled, disconnect the negative battery cable.
2. Disconnect the electrical connector at each injector. Note that the injector harness is specific to injector order. If the harnesses are removed, they must be reinstalled on the correct engine side and to each injector.
3. Clean any dirt or debris near rail connections and injectors.
4. Relieve the fuel system pressure (refer to the vehicle service manual for procedures and precautions for this step).
5. Disconnect the fuel line/lines from the OEM fuel rails. A 3/8" quick-connect tool will be required (available at the local auto parts store). Use clean shop towels to catch any gasoline that may escape and to prevent any contaminants from entering the fuel lines.
6. Disconnect any wiring, vacuum lines, and throttle body components interfering with the installation process.
7. Remove the fuel rail mounting and related hardware.
8. Place clean shop towels around the injectors to catch any gasoline that escapes. Pull up on the OE rail assembly. The injectors are sealed on both ends with O-rings. It is recommended the injectors remain sealed to the fuel rail during removal to prevent large amounts of fuel from escaping onto the engine.
9. Remove injector retaining clips and then remove injectors. Pull straight down on the injectors while gently twisting them.
10. Install the appropriate brackets onto the Holley rails using the supplied 10-32 screws and lock washers. **See bracket configurations below.**
  - a. 2005 – 2008 5.7L & 2005 – 2010 6.1L
    - i. Factory length (48.65mm) injectors

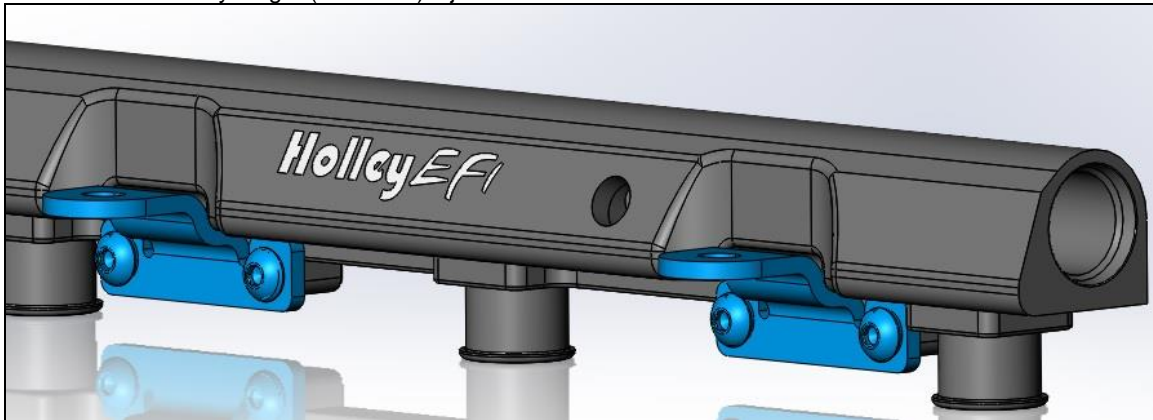

- ii. Long Length (60.65mm) injectors including performance EV1 injectors.

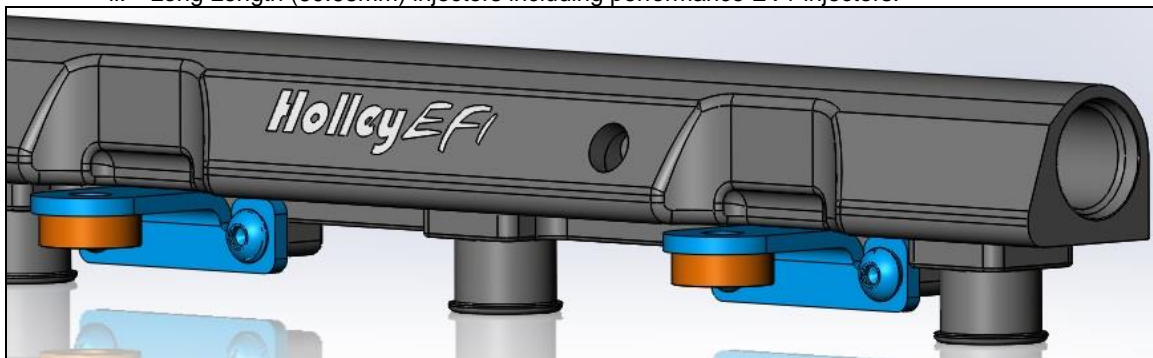

- b. 2009+ 5.7L & 2011+ 6.4L
  - i. Factory length (48.65mm) injectors

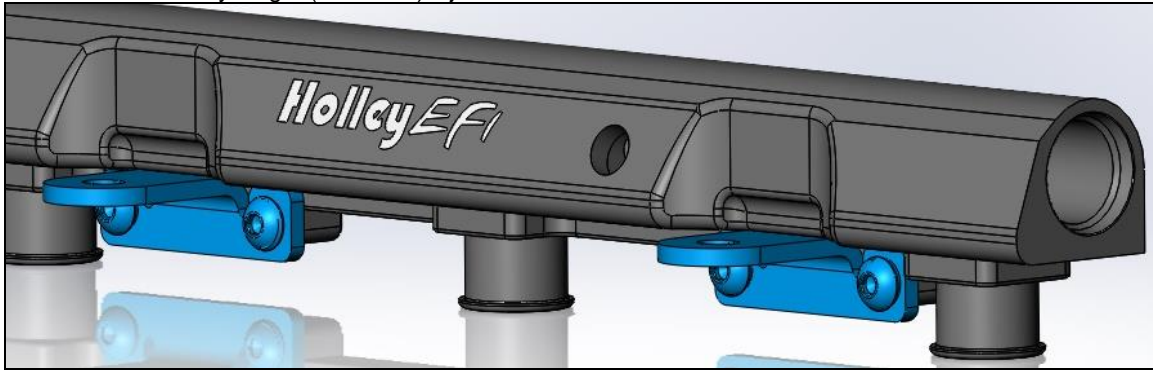

- ii. Long Length (60.65mm) injectors including performance EV1 injectors.

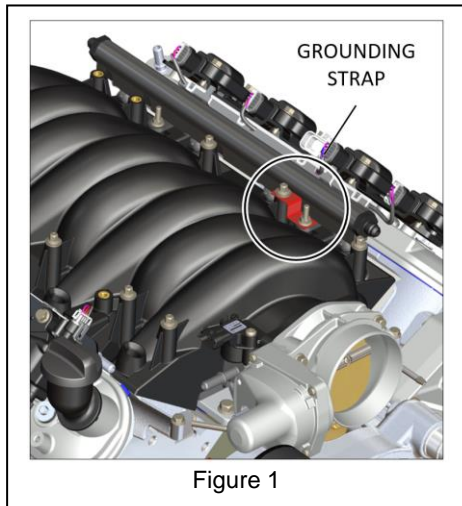
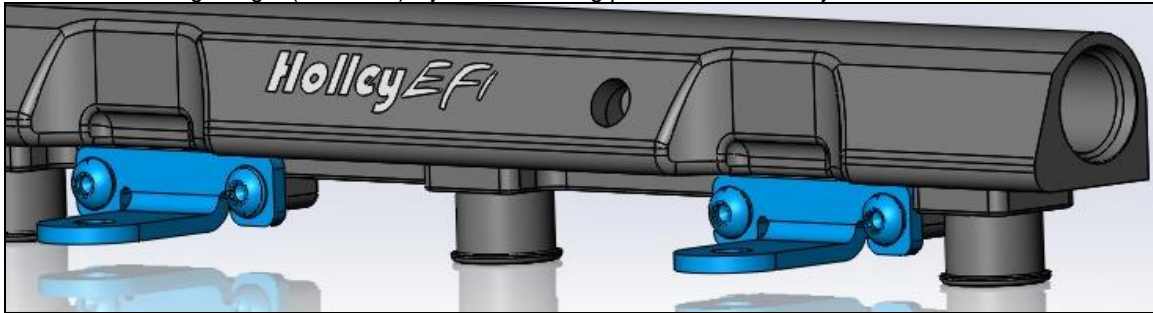

Figure 1

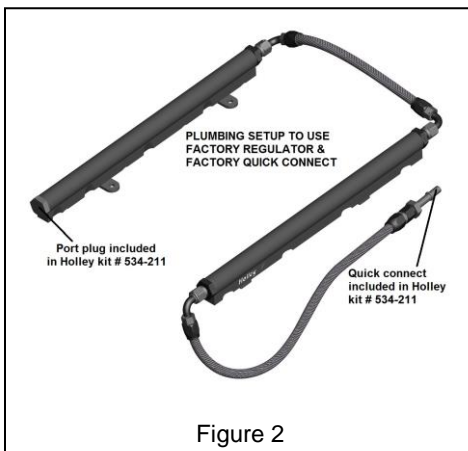
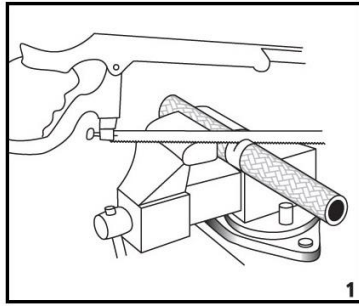

Figure 2

11. Make certain the injectors are free from debris. Inspect each injector O-ring for cracks, nicks, cuts, etc. Replace, if there is any damage. Replacement O-rings are available at your local auto parts store.
12. Apply a light coat of clean oil to all O-rings, intake injector bores, and Holley rail bores for ease of installation.
13. Insert each injector into the fuel injector bore of the Holley rails or into the intake bores, whichever is easier for your particular application. (Optional: reinstall the injector clips to retain the injectors to the Holley rail.)
14. Install each of the fuel rail/injector assemblies onto the intake manifold. Make certain each of the O-rings is seated at both ends and that none of the O-rings were cut.
15. Reinstall the rail mounting bolts. Add a grounding strap for each fuel rail from one of the intake bolts to a rail mounting bolt (**Figure 1**).
16. Reinstall any intake bolts that were removed (refer to vehicle service manual for torque values and pattern for this step).
17. Make certain any spilled gasoline and shop towels are removed.
18. Reconnect any wiring, vacuum lines, and throttle body components that were removed.
19. Plumbing will vary per application. Below is an example (**Figure 2**). Refer to appendix A and B for hose assembly and routing instructions.
20. Reconnect the battery and turn the ignition to the ON position, but do not start the vehicle. To purge air and build fuel pressure, cycle the ignition from off to on several times, waiting at least 10 seconds with the ignition in the off position each time. **Inspect for leaks.**
21. Start the engine and inspect for any fuel leaks around the fuel injectors, fuel rail fittings, fuel lines, etc. Take a brief test drive and check again for any fuel leaks.

## APPENDIX A



1. Cut the hose to the required length.
  - a. Measure distance between ports or adapter fittings along the path that the hose run will follow—allowing for bend radius, hose end length and offset to obtain length and hose required.
  - b. Cut the hose square with a radiac wheel or a sharp 32 teeth per inch hacksaw blade. It is necessary to wrap it tightly with electrical or masking tape before cutting and to cut through the tape. This helps to prevent the stainless wire braid from fraying.
  - c. Trim any frayed ends of the braid with a sharp pair of metal snips or diagonal cutters and remove the tape.

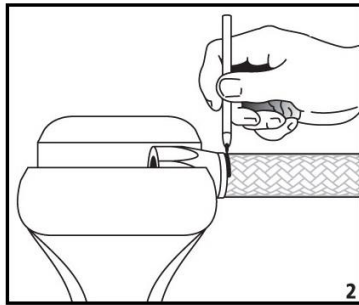

2. Place the socket in a vise and insert the end of the hose into the socket until the hose butts against the bottom of the threads. Gently pull the hose back until there is a 1/16" to 1/8" gap between the end of the hose and the bottom of the socket—mark hose at bottom of socket with a felt pen so that you can detect any tendency of the hose to be pushed out as you complete the assembly.

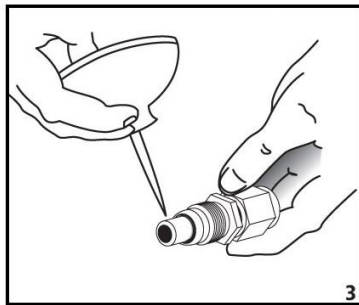

3. Lubricate the inside of the hose, the nipple threads and the socket threads with Earl's Assembly Lube or Engine Oil. Place the nipple in a vise.

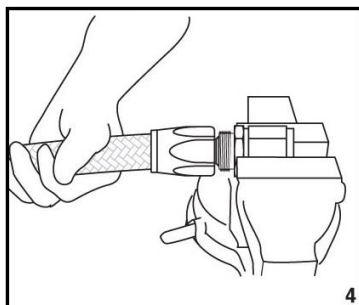

4. Holding the hose and not the socket, push the hose and the socket onto the nipple until the socket threads can be started on the nipple. Holding the hose and not the socket, start the threads and go as far as you can by hand. Depending on the size of the hose, some force may be necessary in this part of the operation.

5. To complete the assembly it doesn't matter whether the nipple or the socket is held in the vise. Holding one or the other in the vise and using a suitable wrench on the other, tighten the socket onto the cutter threads until the socket is within .060" of bottoming on the nipple. Do not use an adjustable or over-size wrench or you will damage either the nipple or the socket.

6. Check the mark that you made on the hose in Step 2. If the hose has backed more than about 1/16" out of the socket as you assembled it, return to Step 3.

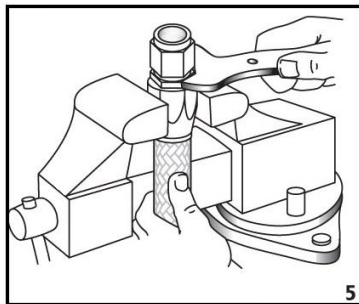

7. Clean the hose and the hose ends with CLEAN solvent.

8. **Pressure test the assembly before letting it out of your sight. Further check the assembly by running the system at full pressure while you observe the hose, hose ends, and adapters for leaks.**

## APPENDIX B

### 1. Provide for length change.

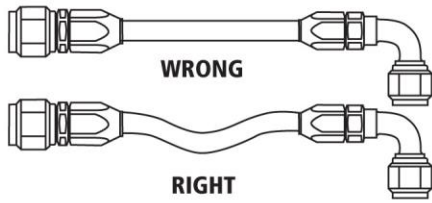

In straight hose installations, allow enough slack in the hose line to provide for changes in length that will occur when pressure is applied. This change in length can be from +2% to -4%.

### 2. Avoid twisting and orient properly.

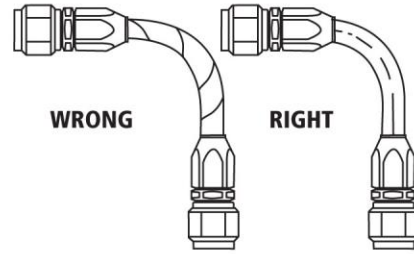

Do not twist during installation. This can be determined by the printed layline on the hose. Pressure applied to a twisted hose can cause hose failure or loosening of connections.

### 3. Protect from hazardous environment.

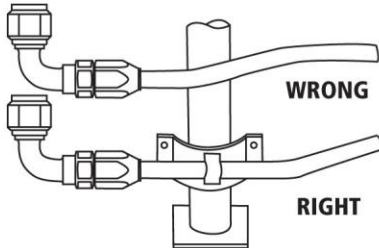

Keep hose away from hot parts. High ambient temperature will shorten hose life. If you can not route it away from heat source, insulate it.

### 4. Avoid mechanical strain.

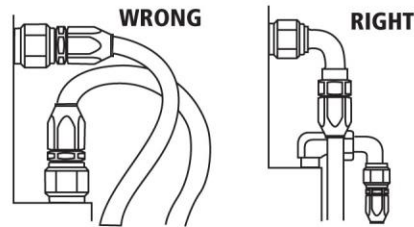

Use elbows and adapters in the installation to relieve strain on the assembly and to provide easier and neater installation that are accessible for inspection and maintenance.

### 5. Use proper bend radius.

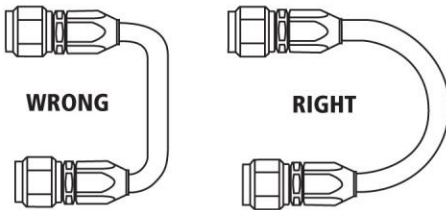

Keep the bend radius of the hose as large as possible to avoid collapsing of the hose and restriction of flow. Follow catalog specs on minimum bend radii.

### 6. Use proper bend radius (cont'd).

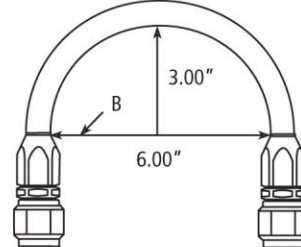

Minimum bend radius is measured on the inside bend of the hose. To determine minimum bend, divide the total distance between ends (B length) by 2. For example, B=6, minimum bend radius=3.

### 7. Secure for protection.

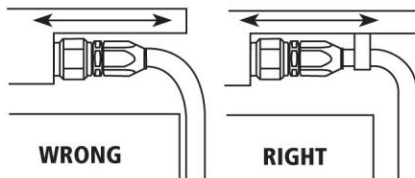

Install hose runs to avoid rubbing or abrasion. Use Earl's Hose Clamps to support long runs of hose or to keep away from moving parts. It is important that the clamps not allow the hose to move. This movement will cause abrasion and temperature hose failure.

### 8. Avoid improper hose movement.

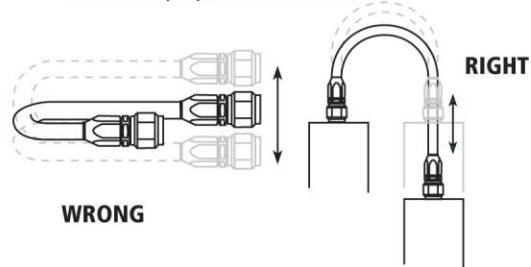

Make sure relative motion of the machine components produces bending rather than twisting of the hose. Hose should be routed so that the flex is in the same plane as the equipment movement.

**199R1280**  
**Date: 5-14-20**