



2134HKR
(Black 63-82 Corvette 265-400)
2134-1HKR
(Coated 63-82 Corvette 265-400)

Thank you for making HOOKER HEADERS your choice in a high-performance exhaust system. Extensive dyno/track testing has enabled HOOKER to offer the most advanced design in headers for your application. Due to the restricted room available in the engine compartment, your headers may be close to some body and chassis components. This condition is normal. The installation, while not complex, may be time-consuming. However, as soon as you start your engine, the additional horsepower and improved performance will more than justify your efforts. Proper installation and maintenance will ensure long life and maximum performance from your HOOKER HEADERS.

WARNING! Breaking in an engine with ceramic-coated headers WILL result in damage to the coating and will VOID all warranties. Ceramic-coated headers require several heat cycles to fully cure before they will withstand extreme heat. HOOKER recommends using a cast-iron exhaust manifold or an old header to break in new engines to avoid coating damage.

BEFORE STARTING

Your vehicle must be raised a minimum of 36 inches, so a floor hoist is ideal. If no hoist is available, we strongly urge the use of axle stands as a safety measure.

CAUTION! YOUR CAR SHOULD NOT BE SUPPORTED ON A BUMPER JACK.

INSTALLATION PROCEDURE – PLEASE READ CAREFULLY

LEFT SIDE

1. Disconnect the battery cable to prevent damage to the electrical system.
2. Unbolt the stock headpipes from the exhaust manifolds. Cut in front of the cross-member and remove.
3. Remove the spark plugs, plug heat shields, stock exhaust manifold, and clutch linkage.
4. Starting from below, work the headers up through all the chassis components into position.
5. Place the gasket into position and start all bolts (most restricted first).

NOTE: Models equipped with a smog pump must remove the injection tubes from the stock exhaust manifold and install in the header. See *Figure A*.

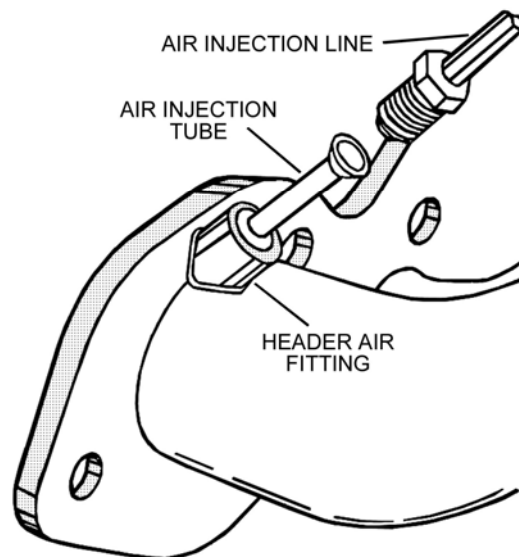

Figure A

6. Tighten all the bolts evenly.
7. Replace the spark plugs, spark plug heat shields, and clutch linkage.

NOTE: Vehicles equipped with alternators mounted on the left side of the head require the purchase of Hooker alternator bracket, P/N 10927HKR. *See Figure B.* If the header is equipped with smog bushings, the bracket must be notched to clear the bushings. *See Figure C.*

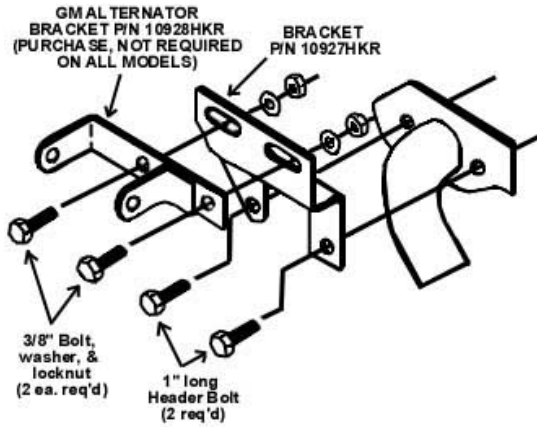

Figure B

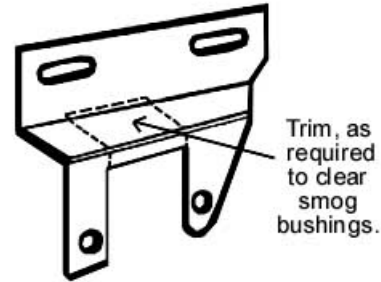

Figure C

RIGHT SIDE

1. Remove the spark plugs, spark plug wires, heat shield from the starter wires (if so equipped), and the splash guard from the frame (if so equipped).
2. Starting from below, work the header up through all the chassis components into position.
3. Position the header gasket and start all bolts (most restricted first).

NOTE: Models equipped with a smog pump must remove the injection tubes from the stock exhaust manifold and install the header. *See Figure A.*

4. Tighten all bolts evenly.
5. Replace the spark plugs and spark plug wires.

NOTE: Models with factory air conditioning mounted on the right side of the motor must modify the mounting bracket. *See Figure D.*

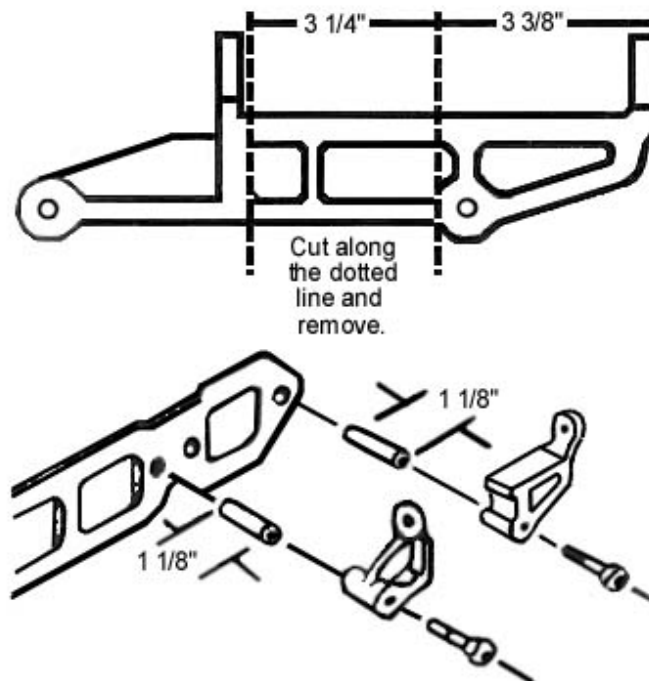

Figure D

NOTE: 1977-78 models employ a different type of bracket. To remount the air conditioning compressor, replace the long stock stud in front of the bolt hole of the flange, fabricate a spacer (3/8" ID x 1-1/4" long, approx. 5/8" OD) and install the compressor according to **Figure E**.

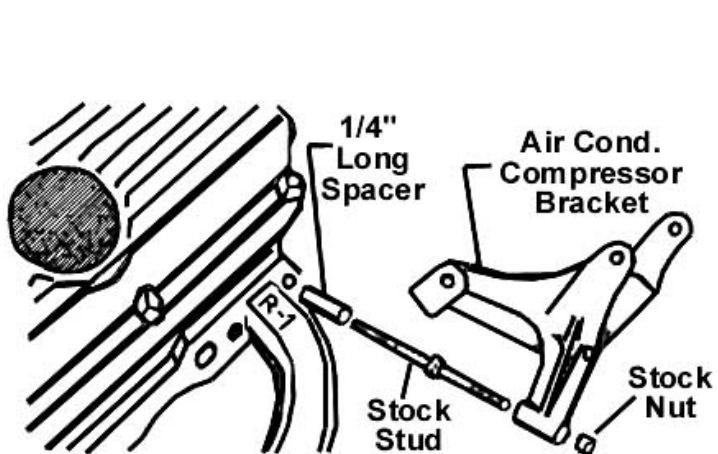

Figure E

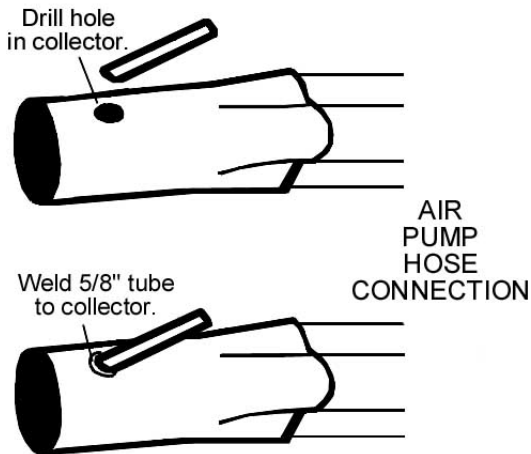
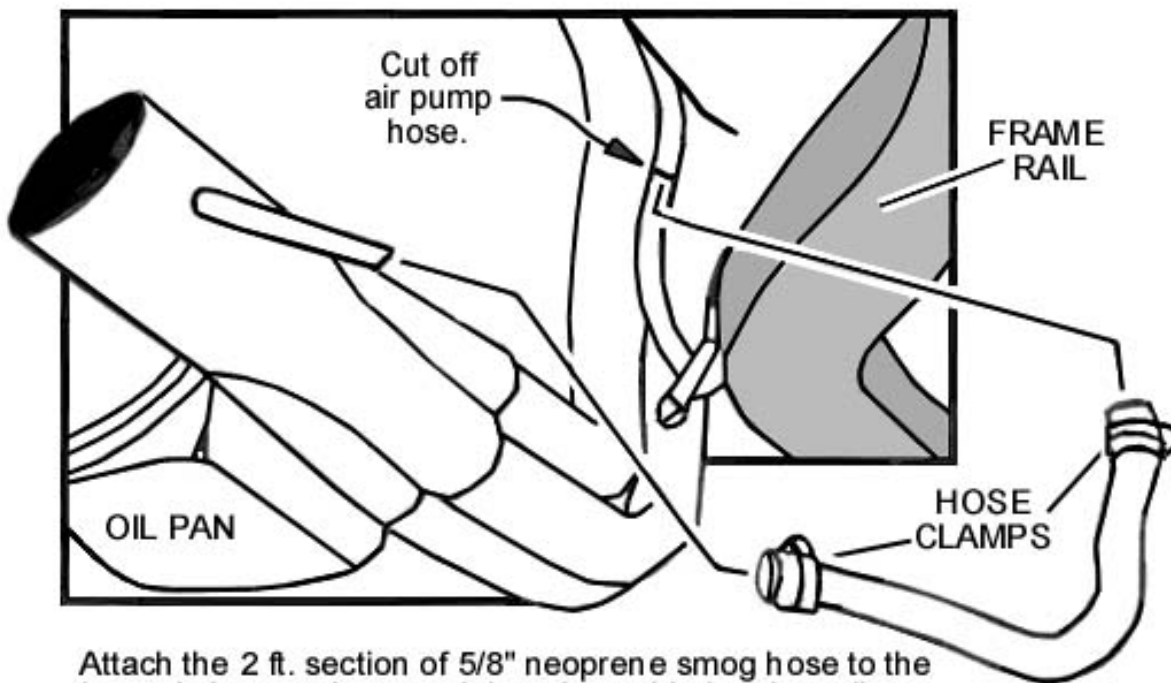

Figure F

NOTE: If the generator/alternator was mounted on the exhaust manifold, purchase the Hooker bracket P/N 10922HKR, to reinstall. If equipped with smog bushings, the bracket must be notched to clear the bushings. **See Figure C.**

NOTE: If the vehicle has a smog air pump connected to the stock exhaust system, it will be necessary to fabricate a connector from a piece of 5/8" OD tubing and weld it to the collector (drill hole before welding). **See Figure F.** Cut the tubing (at a straight section coming from the air pump), connect this collector with a length (approx. 2") of 5/8" ID neoprene hose, and secure with hose clamps. **See Figure G.**



Attach the 2 ft. section of 5/8" neoprene smog hose to the trimmed air pump hose and the tube welded to the collector.

Figure G

6. To connect the collectors to the headpipes, purchase the Hooker reducer kit P/N 11030HKR.
7. Connect the battery, start the engine, and check for leaks. Be sure all brake lines, fuel lines, and electrical wires have sufficient clearance. Reroute, as necessary.

NOTE: On 1963-64 models with factory air conditioning and the compressor mounted on the right side exhaust manifold, Hooker air conditioner bracket P/N 10926HKR will not work. It will be necessary to purchase Hooker generator/alternator bracket P/N 10922HKR and modify it if the air conditioner compressor is to be retained.

Trim the bracket as shown in **Figure I**. Using the bolts supplied with the bracket, attach the right side cylinder head over the #1 header tube. Bolt the stock air conditioner bracket with the compressor attached to the Hooker bracket using (2) 3/8-16 nuts and bolts. Remove one bolt attaching the water pump housing to the right side of the engine block. Fabricate a spacer approximately 1" long to go between the water pump housing and the stock air conditioner bracket. Align the pulley on the air conditioner with the approximate drive pulley on the crankshaft by sighting down the V-belt. Some adjustment in the spacer length may be required. After all components are aligned, install a bolt of sufficient length to hold the air conditioner bracket, spacer, and water pump housing to the engine block. Tighten all the bolts and nuts securely. **See Figure J.**

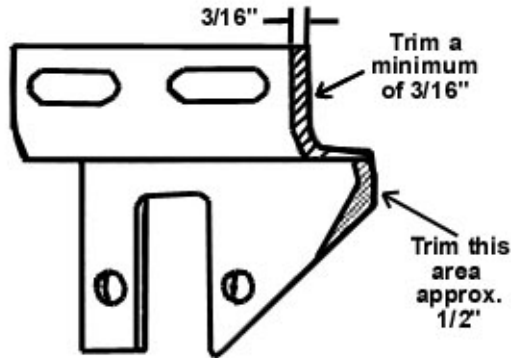

Figure I

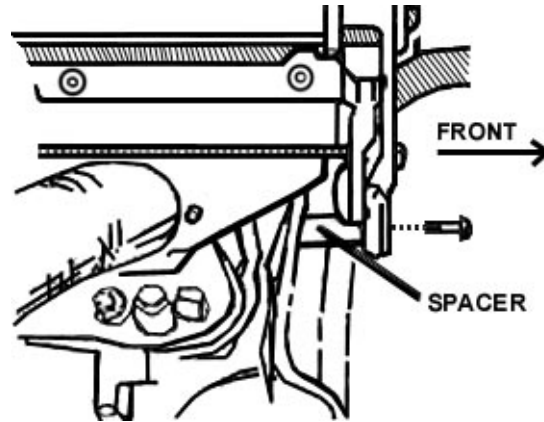

Figure J

8. When finished, give your car a test drive, checking carefully for any new noises. After several days driving, retighten all bolts.

Any questions? Please contact Technical Service: 1-866-GOHOLLEY or 1-270-781-9741. For online help, please refer to the website: www.holley.com.

LIMITATION OF LIABILITY – DISCLAIMER:

The regulation of emissions production, noise levels, and safety standards is undertaken by the federal government, each of the fifty state legislatures, and by many local municipalities, towns, and counties. HOOKER makes no warranties of merchantability, of fitness for particular purpose, or that its products are approved for general use, or that its products are approved for general use, or that its products comply with laws, regulations, or ordinances in the state where they may be sold to the ultimate purchaser, the consumer. Unless expressly stated to the contrary in the catalog, instruction sheet, or price list, the entire risk as to the conformity of any company product in any such state and as to repair should the product prove to be defective or non-conforming, is on the retail purchaser, the buyer, the ultimate consumer, of such product and it is not upon the seller, distributor, or manufacturer. In this connection, the retail purchaser, the buyer, the ultimate consumer assumes the burden of the entire cost of any and all necessary service, alterations, or repair.

THE FOREGOING STATEMENT LIMITS THE LIABILITY OF THE MANUFACTURER.

California vehicle code, sections 27156 AND 38391, prohibit the advertising, offering for sale, or installation of any device, which modifies a vehicle's emission control system, unless exempted, unless otherwise noted. HOOKER Headers have not received an exemption from these code sections and are to legal for sale or use in California on vehicles originally equipped with catalytic converters, it is illegal, except for racing vehicles, which may never be driven upon a highway. To remove or otherwise render inoperative any emission control device on the regulated motor vehicles – check catalog listings to ensure proper application in the other 49 states, unless otherwise noted, HOOKER Headers are not legal for pollution-controlled motor vehicles, except for racing vehicles, which may never be used upon a highway and are not intended or applicable for highway use.