



## P/N 5115HKR (painted) & 5115-1HKR (ceramic coated) SUPER COMPETITION FULL LENGTH MOPAR HEADERS

1966-74 Dodge Challenger, Charger, Coronet, Wagons (B&E Bodies) 318-360

1966-77 Plymouth Belvedere, GTX, Road Runner, Satellite, Sebring, Barracuda (70-74), Sport Fury (75-77), Wagon (B&E Bodies) 318-360

1972-82 Magnum XE & St. Regis 318-360 - 1975-83 Cordoba 318-360 - 1978 Monaco, Polara, Wagons (C Bodies) 318-360

**NOTE:** Will not fit motors equipped with air injection pump without modification.

**NOTE:** Hooker headers for MOPAR 318-360 engines will bolt on the popular aftermarket B-A heads. However, because the exhaust port centerline on these heads is 5/8" higher and 3/8" out from the engine centerline compared to stock heads, some header modifications will be required for installation. Spark plug locations require cutting header flanges for clearance.

**WARNING!** Breaking in an engine with ceramic-coated headers WILL result in damage to the coating and will VOID all warranties. Ceramic-coated headers require several heat cycles to fully cure before they will withstand extreme heat. HOOKER recommends using a cast-iron exhaust manifold or an old header to break in new engines to avoid coating damage.

### **BEFORE STARTING**

Your vehicle must be raised a minimum of 36 inches. A floor hoist is ideal. If no hoist is available, we strongly urge the use of axle stands as a safety measure.

**CAUTION! YOUR CAR SHOULD NOT BE SUPPORTED ON A BUMPER JACK.**

### **INSTALLATION PROCEDURE – PLEASE READ CAREFULLY**

#### **LEFT SIDE:**

1. Disconnect battery cable to prevent damage to the electrical system.
  2. Unbolt the stock headpipes (both sides) and push aside.
  3. Remove the stock exhaust manifold and starter. Drain the radiator if studs are removed from the head.
- NOTE:** Engines with smog heads must have the smog air holes filled. Purchase (8) ¼"-20 x ¼" long Allen head set screws. Thread the holes with a ¼"-20 tap (use a small wrench to turn the tap) and make sure the screw heads are flush with or below the exhaust port surface. See **Figure A**.
4. Separate the drag link from the Pittman arm (may not be necessary on some year models). Try header for fit first. See **Figure B**.
  5. Disconnect the spark plugs wires. Column shift automatics – if shift linkage cross shaft is located under torsion bar, remove it.
  6. Starting from below, work the header up through the chassis, position the gasket on the head, and start all header bolts (most restricted first).

**NOTE:** If replacing studs in the head, we recommend using a sealer on the threads to prevent coolant leakage.

**NOTE:** 1976 models – it may be necessary to remove or trim/bend the heat shield for adequate header clearance.

**NOTE:** Models with floor shift automatics must modify the shift linkage (**Figure C**). Automatics may also need to modify the passing gear linkage (**Figure D**).

7. With the header loose, replace the starter. Check the starter wires for adequate header clearance. Reroute, as required.
8. Replace spark plug wires and shift linkage (if removed).
9. Tighten all header bolts evenly.

#### **RIGHT SIDE:**

1. Remove the stock headpipes and push aside.
2. Remove the stock exhaust manifold (be sure to drain the radiator if the studs are to be removed), oil filter, oil filter adapter (if so equipped), and the brace between the motor and transmission.

**NOTE:** The brace between the motor and transmission may be discarded. It will not be reused.

**NOTE:** Engines with smog heads must have the smog air holes filled. Purchase (8) ¼"-20 x ¼" long Allen head set screws. Thread the holes with a ¼"-20 tap (use a small wrench to turn the tap) and make sure the screw heads are flush with or below the exhaust port surface. See **Figure A**.

3. Turn the front wheels all the way to the left. Starting from below, work the header up through the chassis into position.
4. Position the header gasket and start all bolts (most restricted first).

**NOTE:** If replacing studs in the head, we recommend using a sealer on the threads to prevent coolant leakage.

5. Tighten all header bolts evenly.

6. Work the oil filter and oil adapter (if removed) between the header and bellhousing. Reinstall in the original location. Fill the radiator (if drained).

**NOTE:** The oil filter must be installed and removed (when changing) from the top side of the engine compartment.

7. Replace the drag link on the Pittman arms, making sure the cotter keys are replaced and securely in position.
8. To connect the collectors to the headpipes, purchase Hooker Reducer Kit #11035HKR. Bolt the reducers (with gaskets) to the collectors, line up the headpipes, cut to the correct length, and weld to the reducers.

**NOTE:** A dual exhaust system can be fabricated using either Hooker Super Competition Turbo mufflers 21105HKR or 21106HKR or Hooker Competition Turbos 21005HKR or 21006HKR.

9. Connect the battery, start the engine, and check for leaks. Be sure all brake lines, fuel lines, transmission cooler lines, and electrical wires have sufficient clearance. Reroute as necessary.
  10. When finished, give your vehicle a test drive, checking carefully for any new noises. After several days of driving, retighten all bolts.
- Any questions? Please contact Technical Service: 1-866-GOHOLLEY or 270-781-9741. For online help, please refer to the website: [www.holley.com](http://www.holley.com).

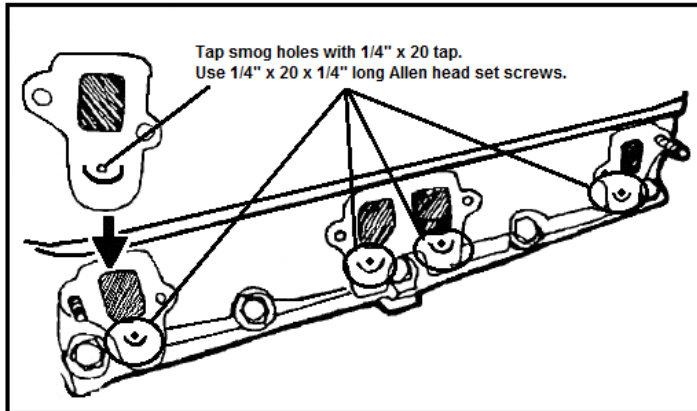

Figure A

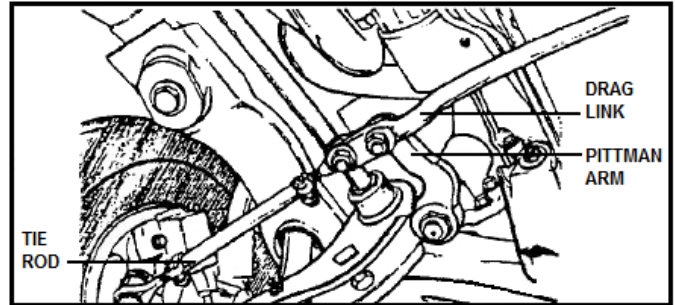

Figure B

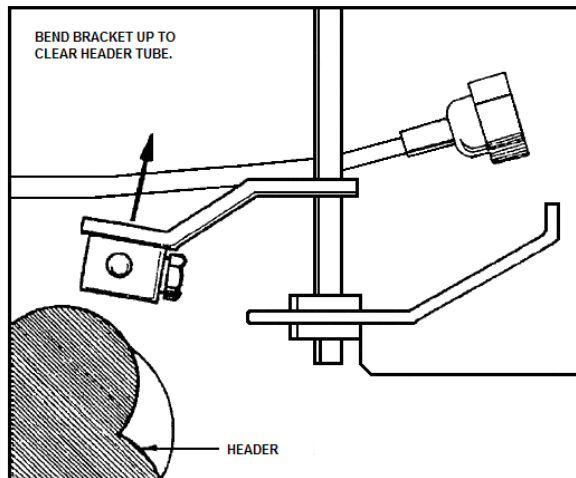

Figure C

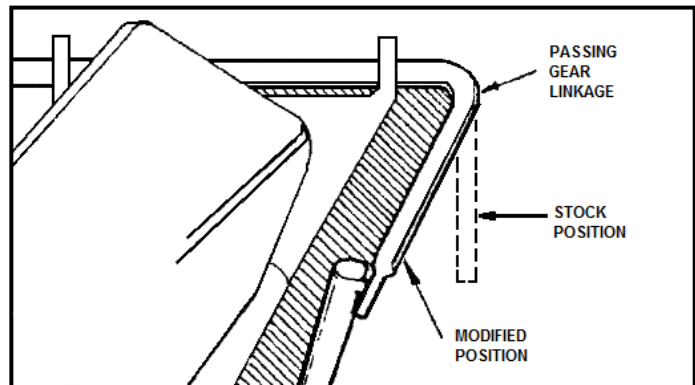

Figure D

**LIMITATION OF LIABILITY – DISCLAIMER:**

The regulation of emissions production, noise levels, and safety standards is undertaken by the federal government, each of the fifty state legislatures, and by many local municipalities, towns, and counties.

HOKKER makes no warranties of merchantability, of fitness for particular purpose, or that its products are approved for general use, or that its products are approved for general use, or that its products comply with laws, regulations, or ordinances in the state where they may be sold to the ultimate purchaser, the consumer.

Unless expressly stated to the contrary in the catalog, instruction sheet; or price list, the entire risk as to the conformity of any company product in any such state and as to repair should the product prove to be defective or non-conforming, is on the retail purchaser, the buyer, the ultimate consumer, of such product and it is not upon the seller, distributor, or manufacturer.

In this connection, the retail purchaser, the buyer, the ultimate consumer assumes the burden of the entire cost of any and all necessary service, alterations, or repair.

**THE FOREGOING STATEMENT LIMITS THE LIABILITY OF THE MANUFACTURER.**

California vehicle code, sections 27156 AND 38391, prohibits the advertising, offering for sale, or installation of any device, which modifies a vehicle's emission control system, unless exempted, unless otherwise noted. HOKKER Headers have not received an exemption from these code sections and are to legal for sale or use in California on vehicles originally equipped with catalytic converters, it is illegal, except for racing vehicles, which may never be driven upon a highway. To remove or otherwise render inoperative any emission control device on the regulated motor vehicles – check catalog listings to ensure proper application in the other 49 states, unless otherwise noted, HOKKER Headers are not legal for pollution-controlled motor vehicles, except for racing vehicles, which may never be used upon a highway and are not intended or applicable for highway use.

**5115HKR**  
**Date: 6-14-11**