

Installation Instructions for 30501 2-1/2" Dual Exhaust Kit w/o Turbo Mufflers

Application: A-body, '67-74 Dart/Duster/Demon/Valiant, '67-69 Barracuda, all with V8, standard Hooker Competition headers (otherwise modifications may be necessary), and with 3" collectors at the headers.

NOTE: For those with 3-1/2" collectors, you will need to purchase an additional header collector kit.

NOTE: The headers and mufflers are not included in this kit!! We recommend use of Hooker competition headers. Modifications may need to be made for different styles of headers, including cutting and welding. For vehicles with 3-1/2" collectors, you will need to order a 3-1/2" header collector kit, part # 30006 (trimming of 1 collector will be required).

Hardware Kit Includes:

- 2) LB4 Hangers
- 12) 2-1/2" Clamps
- 2) 5/16" x 1" Bolts
- 2) 5/16" x 1" Lag Screws
- 2) Snapper Grommets
- 2) BR91930 Swinger Hangers
- 2) #MP48005 3" Collector Gaskets
- 2) 5/16" x 1-1/2" Bolts
- 6) 3/8" x 1-1/4" Bolts
- 4) 5/16" Lock Washers
- 6) 3/8" Lockwashers
- 6) 3/8" Nuts
- 4) 5/16" Nuts
- 2) F33 Flanges

Pipe Kit Includes:

- 1) Left Front Extension Pipe--#8158741
- 1) Right Front Extension Pipe--#8158742
- 1) Left Rear Extension Pipe--#8158743
- 1) Right Rear Extension Pipe--#8158744
- 1) Left Tail Pipe--#8158747
- 1) Right Tail Pipe--#8158748
- 1) Left Over-The-Axle Pipe--#8158745
- 1) Right Over-The-Axle Pipe--#8158746
- 1) Short Header Collector, Passenger Side--#8158749
- 1) Regular Header Collector, Driver Side

DANGER WARNING:

Should the purchaser decide to install this exhaust product at home, be warned that pleasure car or light duty truck/van "bumper" jacks are intended for emergency use only. The use of frame contact jack stands in conjunction with a floor jack as main support is highly recommended to minimize accidental dropping of a vehicle while the installation proceeds. We recommend the use of a shop hoist if possible. Please use caution!

Limitation of Liability--Disclaimers: The regulation of emissions production, noise levels and safety standards is undertaken by the federal government, each of the fifty state legislatures, and by many local municipalities, towns and counties.

The manufacturer makes no warranties of merchantability, of fitness for a particular purpose, or that its products are approved for general use, or that its products comply with laws, regulations or ordinances in the states where they may be sold to the ultimate purchaser, the consumer.

The entire risk as to the conformity of this product in any such state and as to repair, should the product prove to be defective or non-conforming, is on the retail purchaser, the buyer, the ultimate consumer of such product and it is not upon the seller, distributor, or manufacturer.

In this connection, retail purchaser, the buyer, the ultimate consumer assumes the burden of the entire



1-800-345-4545 **jegs.com**

NOTE: DO NOT TIGHTEN ANY BOLTS OR CLAMPS UNTIL THE LAST STEP!

1. Raise the automobile in a safe and suitable manner--support with jack stands onto the frame.
2. Remove the old exhaust system after the headers. Remove the old hangers and brackets if desired. New universal hangers are included in this kit to replace the original hangers.
3. Install the collectors to the headers using the MP48005 gaskets and F33 flanges, and enclosed hardware. Tighten these at this time, using the 3/8" x 1-1/4" bolts and nuts. The driver side takes the long header collector, the passenger side the short (to clear cross member).
4. Install the I.D. ends of the left (#8158741—2 bends) and right (#8158742—3 bends) front extension pipes to the collectors using 2-1/2" clamps. Be sure to leave adequate clearance between the floor boards, the drive shaft, and the crossmember. The right front extension pipe should just clear the recess in the crossmember. NOTE: If these pipes do not fit your headers, you may need to modify as necessary (cut and weld) for fit. These kits were designed for use with hooker competition headers.
5. Install the I.D. ends of the left (#8158743—3 bends) and right (#8158744—2 bends) rear extension pipes to the left and right front extension pipes, using 3" clamps.
6. Install the mufflers (offset in, towards drive shaft/center out, not included) onto the rear extension pipes using 2-1/2" clamps. Rotate the extension pipes to clear the driveshaft, and frame, and general clearance.
7. Install the BR91930 hangers to the vehicle. If your vehicle has factory, dual exhaust and the hanger bracket on both sides use a 5/16" nut, bolt, lock, and fender washer to install the hanger to the O.E. bracket. If your vehicle does not have the O.E. bracket on the passenger side, you will need to drill a hole or holes in the floor boards and either use the enclosed lag screws or the 5/16" bolt, nut, lock and fender washers.
8. Install the left (#8158745) and right (#8158746) over-the-axle pipes to the mufflers using 2-1/2" clamps.
9. Install the left (#8158747) and right (#8158748) tail pipes to the over-the-axle pipes using 2-1/2" clamps.
10. Install the LB4 hanger and the grommet to the frame at the rear, after the axle, using the existing hole in the frame at the O.E. hanger bracket. Use the 5/16" x 1-1/2" bolt, nut, and lock washer, and the grommet. Use a 2-1/2" clamp to connect the hanger and the tail pipes. Cut the tail pipes to your desired length and look.
11. Make sure that all the parts of the system are clear of frame members, the cross member, driveshaft, floor, all hoses, suspension, and brake and fuel lines. Starting at the collector pipes, tighten all connections and nuts. Make sure all parts are clear and will not leak or rattle. After several days of driving retighten all bolts.

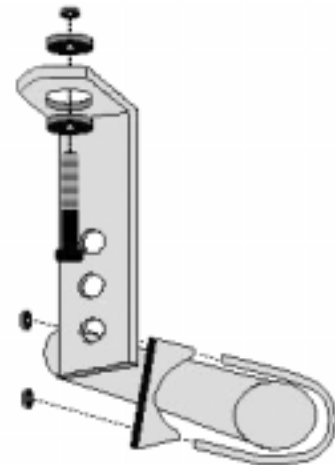
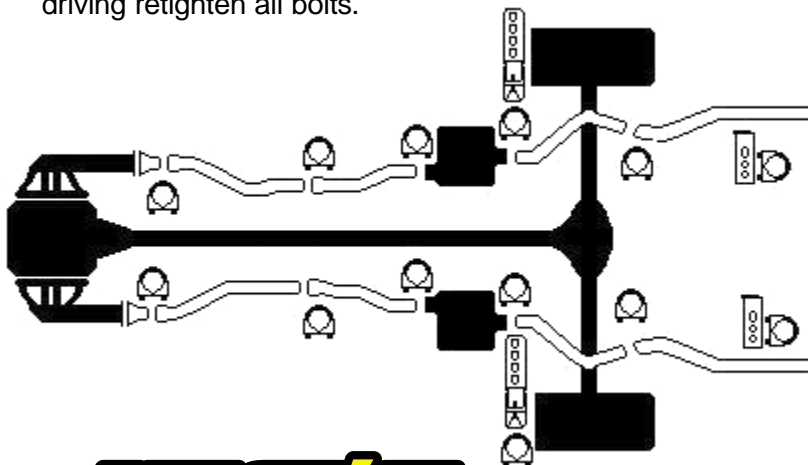

JEG'S
Performance Products

1-800-345-4545 jeps.com