

# ***Installation Instructions for SSR Distributors***

## **GENERAL INFORMATION**

1. **IMPORTANT:** Read all instructions before starting installation.
2. JEGS SSR Distributors come with hardened steel distributor gears which should not be used in applications with a billet camshaft. Consult camshaft manufacturer for distributor gear compatibility.
3. **WARNING!!! DO NOT USE WITH SOLID CORE IGNITION WIRES.**
4. Engines that have been decked, had significant cylinder head milling, or oil pump modification should be checked for oil pump bind and proper distributor gear mesh prior to installation.

## **DISTRIBUTOR REMOVAL**

1. Crank the engine until the number 1 cylinder is positioned at top dead center on compression stroke. The timing indicator should point to 0.
2. Remove the distributor cap, and make sure that the rotor is pointing towards the first cylinder in the firing order.
3. Disconnect the battery negative (-) cable.
4. Disconnect all wires and hoses attached to the distributor.
5. Remove the distributor hold down.
6. Remove the distributor by lifting up on the distributor housing while slightly turning the rotor.
7. Check the distributor gear for signs of excess wear, or potential problems.

## **DISTRIBUTOR INSTALLATION**

**NOTE:** JEGS Distributors are factory set for standard deck height engines. If your application requires a taller installed height, refer to the "ADJUSTING THE SLIP COLLAR" section of this manual.

1. Remove the distributor cap.
2. Install the distributor gasket over the gear, and up to the distributor collar. Use a small amount of gasket adhesive to help hold the gasket in place.
3. Lubricate the distributor gear and distributor shaft with clean engine oil.
4. Turn the shaft so that when the distributor is placed into the engine, the rotor position matches that of the original distributor. As the distributor drops down, the rotor will turn slightly as it engages with the camshaft gear. Adjust for this rotation by turning the rotor a few degrees prior to the gear engagement. Several attempts may be necessary to achieve the proper rotor position. The distributor collar should sit completely flat on the intake manifold or block.
5. Place the distributor cap onto the housing.
6. Turn the housing so that the terminal, that represents the first cylinder in the firing order, lines up with the rotor.
7. Install the distributor hold down and tighten the hold down bolt slightly. Insure that the distributor is grounded properly thru the hold down bracket. Once the ignition timing is adjusted the hold down bolt should be tightened completely.
8. Tighten the cap into place and install the spark plug wires in the proper firing order.
9. Locate the vacuum hose that was previously attached to the vacuum advance canister. This hose should originate at a ported vacuum source. Remove the vacuum hose and plug the vacuum port.



**1-800-345-4545 [jeps.com](http://jeps.com)**

## **ADJUSTING THE SLIP COLLAR**

**NOTE:** Non Standard deck height engines require adjustment of the slip collar for proper distributor gear mesh and oil pump drive engagement. Follow the steps outlined below to insure proper distributor installation.

1. Loosen the slip collar set screws and main clamp socket head screw. The collar should move freely on the distributor housing.
2. Remove the distributor gasket from the distributor housing.
3. Install the distributor into the engine until it bottoms out on top of the oil pump drive shaft. Press down firmly on the distributor body to insure it's fully seated.
4. While holding the slip collar firmly against the intake manifold. Tighten the slip collar socket head screw and set screws.
5. Remove the distributor and install the provided 0.060 in. gasket.
6. Coat the distributor gear with moly grease.
7. Re-install the distributor in the same method as outlined in the section of this manual titled "DISTRIBUTOR INSTALLATION".
8. Tighten the distributor hold down.
9. Crank the engine over a few revolutions and remove the distributor in the same method as outlined in the section titled "DISTRIBUTOR REMOVAL".
10. Look at the marks left in the moly grease on the gear. Proper alignment should leave an even pattern across the middle of the gear.
11. If additional adjustment is necessary, repeat step #3 and while holding the slip collar flat against the manifold. Move the distributor body up by the desired amount. Tighten the slip collar socket head screw and set screws.
12. Re-install the distributor in the same method as outlined in the section titled "DISTRIBUTOR INSTALLATION".

## **WIRING**

JEGS SSR Distributor can be used in conjunction with most ignition coils rated at 0.45 ohms or greater. For optimum performance purchase and install a high-performance coil.

1. Many vehicles came equipped with ballast resistors or resistance wires. To achieve optimum performance we recommended removal of these components.
2. Determine the proper wire length, and attach the provided terminals. (Use a designated wire crimping tool to achieve an adequate connection)
3. Attach the **Red** wire to the coil positive terminal or a 12-volt ignition source.
4. Attach the **Black** wire to the coil negative terminal.
5. Check to insure correct polarity and that all connections are tight.
6. Reconnect the battery negative cable.

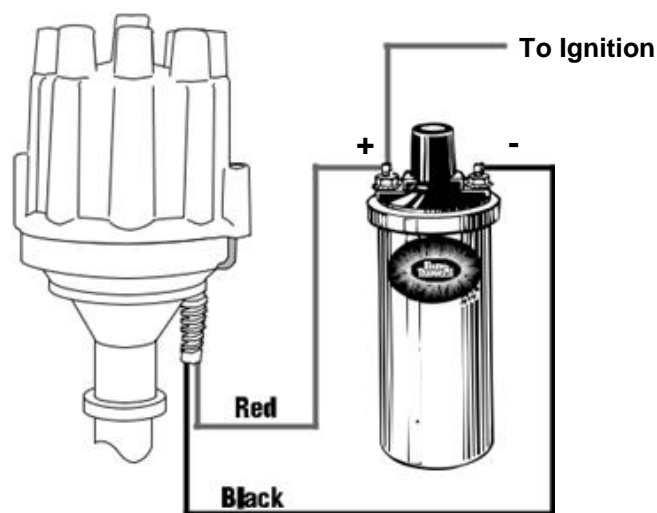

**FINAL ADJUSTMENTS**

1. **WARNING!!! DO NOT USE WITH SOLID CORE SPARK PLUG WIRES.**
2. Start the engine and set the initial timing.
3. Tighten the distributor hold down.

**MECHANICAL ADVANCE ADJUSTMENTS**

1. To adjust the mechanical advance curve, select the appropriate springs from the chart below.
2. JEGS SSR Distributor is factory equipped with the silver springs.
3. Remove the cap and rotor.
4. Remove the existing springs and install the desired springs.
5. Reinstall the rotor and cap.

	R.P.M.										
	500	1000	1500	2000	2500	3000	3500	4000	4500	5000	5500
<b>Copper</b>	0	5	16	24	24	24	24	24	24	24	24
<b>Silver</b>	0	0	3	10	16	22	24	24	24	24	24
<b>Bronze</b>	0	0	0	3	7	10	14	18	22	24	24

**Crankshaft Degrees**

**JEGS SSR Distributor comes with three different sets of advance limiters. These allow the maximum mechanical advance to be limited to 20, 16 or 12 degrees.**

1. Choose the desired advance limit from the chart below.
2. Remove the distributor cap and rotor.
3. Remove the advance springs.
4. Install one advance limiter on each inner advance pin. (See Figure 1)
5. Reinstall the advance springs.
6. Reinstall the rotor and cap.
7. The advance limiters can be mixed resulting in unique variations of the original advance curve. When combined with mixed advance springs and limiters the mechanical advance can have a maximum of 78 different advance curves.

LIMITER	TOTAL MECHANICAL ADVANCE
6 OR NONE	12 DEGREES
8 OR BLUE	16 DEGREES
10 OR RED	20 DEGREES

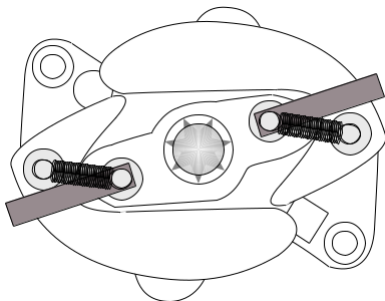

**Figure 1**

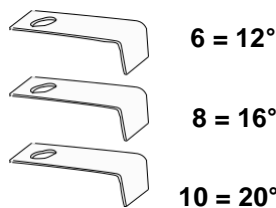

**Figure 2  
(New Version)**

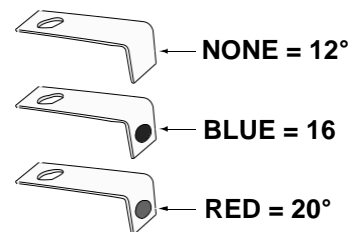

**Figure 3  
(Older Version)**



**1-800-345-4545 [jeps.com](http://jeps.com)**