

Installation Instructions for 80617
Strut Coil Spring Compressor
 1-Ton Capacity

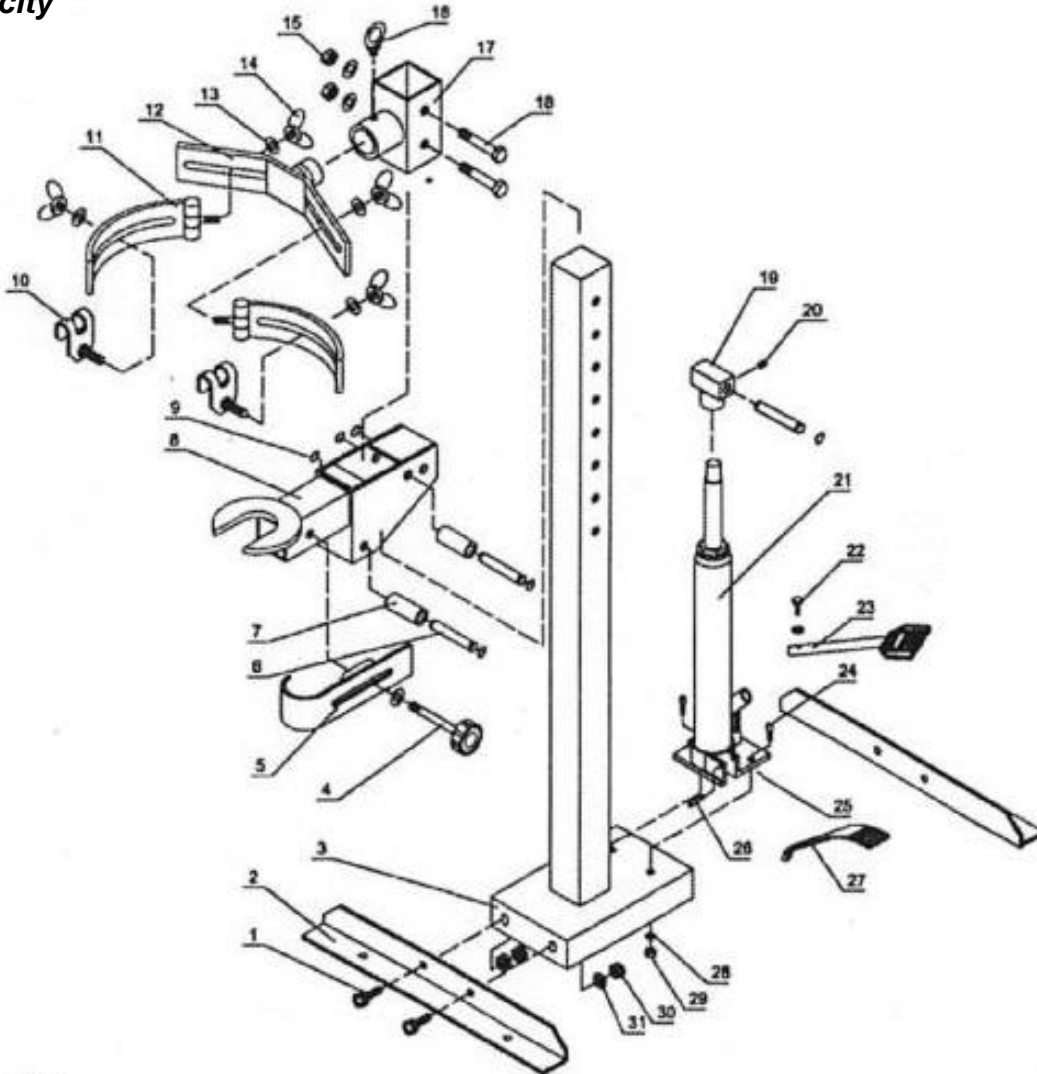

PARS LIST

Part No.	Description	Qty	Part No.	Description	Qty	Part No.	Description	Qty
1	Bolt	4	12	Spring clasp bracket	1	23	Lift foot pedal	1
2	Bracket	2	13	Washer	7	24	Bolt	2
3	Upright	1	14	Fly nut	4	25	R-pin	1
4	Screw rod	1	15	Nut	2	26	Pin	1
5	Adjustable strut shaft clasp	1	16	Screw ring	1	27	Release foot pedal	1
6	Handle sleeve	3	17	Upper strut support	1	28	Washer	3
7	Bushing	2	18	Bolt	2	29	Nut	2
8	Lower strut support	1	19	Saddle	1	30	Nut	4
9	Retaining ring	6	20	Screw	1	31	Washer	4
10	Spring clasp claw	2	21	Bottle jack	1			
11	Spring clasp holder	2	22	Bolt	1			



1-800-345-4545 jeps.com

IMPORTANT

PLEASE READ THESE INSTRUCTIONS CAREFULLY. NOTE THE SAFETY INSTRUCTIONS AND WARNINGS. USE THE PRODUCT CORRECTLY AND WITH CARE FOR THE PURPOSE FOR WHICH IT IS INTENDED. FAILURE TO DO SO MAY CAUSE DAMAGE TO PROPERTY AND/OR SERIOUS PERSONAL INJURY. PLEASE KEEP THIS INSTRUCTION MANUAL SAFE FOR FUTURE USE.

1. SAFETY INSTRUCTIONS AND WARNINGS

- 1.1 Use a qualified person to maintain the strut spring compressor in good condition. Keep it clean for best and safest performance.
- 1.2 The maximum load is 1ton. **DO NOT** exceed this rated capacity.
- 1.3 Use the compressor only on passenger cars and pickup truck. **DO NOT** use it for any other purpose it is not designed to perform.
- 1.4 Keep children and unauthorized persons away from the work area.
- 1.5 Remove loosen clothing. Remove ties, watches, ring and other loose jewelry, and contain long hair.
- 1.6 Wear ANSI approved safety goggles when using the strut spring compressor.
- 1.7 Keep proper balance and footing, **DO NOT** overreach and wear non-skid footwear. Always keep your fingers, hands and feet away from compressing area.
- 1.8 Only use this compressor on a surface that is stable, level, dry and not slippery, and capable of sustaining the load. Keep the surface clean, tidy and free from unrelated materials and ensure adequate lighting.
- 1.9 Inspect the tool before each use. **DO NOT** use if bent, broken, cracked, leaking or otherwise damaged, any suspect parts are noted or it has been to a shock load.
- 1.10 Use extreme caution when applying or releasing a load. Never allow the load to suddenly drop. Slowly and carefully apply and release the load.
- 1.11 **DO NOT** allow any lubricants to contact the spring clasp bracket (12), spring clasp holder (11), spring clasp/claw (10), lower strut support (8), adjustable strut shaft clasp (5) as that will diminish the ability of the strut spring compressor to firmly and safely grip and hold a strut spring in position, which may result in personal injury and/or property damage.
- 1.12 **DO NOT** operate the compressor when you are tired or under the influence of alcohol, drugs or any intoxicating medication.
- 1.13 **DO NOT** allow untrained persons to operate the strut spring compressor.
- 1.14 **DO NOT** make any modifications to the strut spring compressor.
- 1.15 **DO NOT** use brake fluid or any other improper fluid and avoid mixing different types of oil when adding hydraulic oil. Only good quality hydraulic oil can be used.
- 1.16 **DO NOT** expose the compressor to rain or any other kind of bad weather.
- 1.17 If the compressor need repairing and/or there are any parts that need to be replaced, have it repaired by authorized technicians and only use the replacement parts supplied by the manufacturer.
- 1.18 **WARNING:** the warnings, cautions and instructions discussed in this instruction manual cannot cover all possible conditions and situations that may occur. It must be understood by the operator that common sense and caution are factors, which cannot be built into this product, but must be supplied by the operator.

2. SPECIFICATIONS

Capacity	1Ton	Max Working Length	59.4cm 23-3/8in
Ram Stroke	33cm 13 in	Jack Height	41.9cm 16-1/2 in
Spring Size	10.2-25.4cm 4in-10 in		
Base Size	36.1×50.2cm 14-1/5 in×19-3/4 in		

3. ASSEMBLY

Use the exploded drawing as your guide to assemble the compressor. Lay all parts and assemblies out in front of you before beginning. The following procedure is recommended.

- 3.1 Take the upright (3) out of the carton, then attach the brackets (2) to the upright by inserting the bolts (1) into the hole in the base of the upright (3) and tightening the nuts and washers (30,31).
- 3.2 Temporarily remove the upper strut support (17) away from the upright (3) by unscrew the bolts (18) and the nuts (15).
- 3.3 Temporarily remove the screw (20) on the bolt in the saddle (19), Slid the lower strut support (8) down



1-800-345-4545 jeps.com

- the upright (3) until it rests firmly on the ram of the bottle jack (21), then tighten the screw (20).
- 3.4 Re-attach the upper strut support (17) to the upright by inserting and tightening the bolts (18) and nuts (15) through the aligned holes both in the upper strut support (17) and the upright (3). The holes you need in the upright (3) are just in accordance with the height of the strut spring to be compressed.
- 3.5 Attach the spring clasp assembly (10,11,12,13,14) to the upper strut support (17) by firmly wrench the screw ring (16).
- 3.6 Attach the lift foot pedal (23) to the bottle jack (21) using bolt (22).

4. BEFORE FIRST USE

- 4.1 Depress the release foot pedal (27) to lower the ram of the bottle jack (21) in its lowest position.
- 4.2 Fully Press the release foot pedal (27) and pump the lift foot pedal (23) 6 to 8 times to eliminate any air in the system.
- 4.3 Test the strut spring compressor.

5. OPERATING INSTRUCTIONS

WARNING! Ensure that you read, understand and apply the safety instructions and warnings before use.

WARNING! Ensure that you have familiarized yourself thoroughly with the product and the hazards associated with its improper use.

NOTE: Always refer to and have available a credible service manual covering the year, make and model of the vehicle being serviced. Follow manufacture's guidelines for strut removal, service and installation procedures.

- 5.1 De-grease the spring to be compressed. Never attempt to compress a dirty spring.
- 5.2 Depress the release foot pedal (27), and lower the ram in its lowest position.
- 5.3 Secure base of vehicle's strut spring assembly in compressor fixture by adjust the adjustable strut shaft clasp (5).
- 5.4 Remove the bolts (18) and the nuts (15), then slid the upper strut support (17), and the attached spring clasp assembly (10,11,12,13,14), up and down along the upright (3), until the spring clasp assembly is at about the same height as the top of the vehicle's strut spring assembly. Once the desired height of the spring clasp assembly is reached, secure the upper strut support (17) on the upright (3) by re-inserting and tightening the bolts (18) and the nuts (15).
- 5.5 Secure vehicle's strut spring with spring clasp/claw (10).

NOTE: Check to make sure that both the top and the base of the vehicle's strut spring assembly is firmly secured in place.

- 5.6 Slowly pump the lift foot pedal (23) to compress the vehicle's strut spring.
- 5.7 After the spring is fully compressed, remove nut and retainer cup assembly.
- WARNING!** Do not remove the nut with first compressing the spring. Only compress spring sufficiently to remove retaining nut and hardware.
- 5.8 Decompress the spring by depressing the release foot pedal (27) and remove it. Replace damaged components.
- 5.9 Install spring and pump to compress.
- 5.10 Install retainer cup assembly and nut. Tighten retainer nut.
- 5.11 Decompress spring by depress the release foot pedal (27) and remove vehicle's strut spring assembly from fixture.

6. MAINTAINANCE

CAUTION: Always release the load from the strut spring compressor before you do any service for it.

- 6.1 Lubrication of upright (3) is required in normal service.
- 6.2 Clean the outside of the compressor with a dry, clean and soft cloth. Wipe off the strut spring compressor using a mild detergent.
- 6.3 When not in use, the compressor should be stored in a dry location with ram fully retracted to inhibit rust and covered with a cloth cover.
- 6.4 Before each use check all parts. If any part of the compressor is damaged or suspect, remove the compressor from service and take necessary action to repair.
- 6.5 Check the hydraulic oil level: remove the filler plug on the bottle jack (21), if the oil is not adequate, fill with high quality hydraulic oil to the lower rim of the fill hole.
- 6.6 When compress efficiency drops, purge away air from the bottle jack (21) as described in 4.2.



1-800-345-4545 jegs.com