

Installation Instructions for 80618

Single Action Strut Spring Compressor

Specifications

Capacity	7" Coil Spring Diameter
Maximum Opening	8"
Lead Screw Torque	15 ft-lb minimum
Compressor Type	MacPherson Struts Only

Save This Manual

You will need the manual for the safety warnings and precautions, assembly instructions, operating and maintenance procedures, parts list and diagram. Keep your invoice with this manual. Write the invoice number on the inside of the front cover. Keep the manual and invoice in a safe and dry place for future reference.

Safety Warnings

WARNING Read all safety warnings and instructions. *Failure to follow the warnings and instructions may result in electric shock and/or serious injury.* Save all warnings and instructions for future reference.

1. Tighten and release evenly and slowly. Only use hand tools to tighten/release. Do not use any air, electric, or impact tools with this tool. Only operate this tool with a 3/4" socket and ratchet, 3/4" combination wrench, or other applicable hand tools. Power, air, or electric tools may compress the spring too quickly leading to injury.
2. Use provided pins to secure spring in place before use.
3. Set compressed spring in safe area. Be careful when spring is compressed. Do not drop or jar spring. Doing so might result in the spring forcefully flying free, causing personal injury or damage.
4. Do not use on springs larger than 7" diameter.
5. Wear ANSI-approved safety goggles and heavy-duty work gloves during use.
6. Inspect before use; do not use if parts are loose or damaged.
7. **OBSERVE WORK AREA CONDITIONS.** Keep work area clean and well lit.
8. **Use the right tool for the job.** Do not attempt to force a small tool or attachment to do the work of a larger industrial tool. There are certain applications for which this tool was designed. Do not modify this tool and do not use this tool for a purpose for which it was not intended.
9. **Stay alert.** Watch what you are doing, use common sense. Do not operate any tool when you are tired.
10. **Check for damaged parts.** Before using any tool, any part that appears damaged should be carefully checked to determine that it will operate properly and perform its intended function. Check for alignment and binding of moving parts; any broken parts or mounting fixtures; and any other condition that may affect proper operation. Any part that is damaged should be properly repaired or replaced by a qualified technician.
11. **Replacement parts and accessories.** When servicing, use only identical replacement parts. Use of any other parts will void the warranty. Only use accessories intended for use with this tool.
12. **Do not operate tool if under the influence of alcohol or drugs.** Read warning labels on prescriptions to determine if your judgement or reflexes are impaired while taking drugs. If there is any doubt, do not operate the tool.
13. For your safety, maintenance should be performed regularly by a qualified technician. Have a qualified service technician inspect this tool annually.



1-800-345-4545 jeps.com

14. Only use this tool with MacPherson struts. Do not use with high pitched springs.
15. If spring coils do not compress evenly, loosen the adjusting screw, reposition the strut spring, and retry.
16. Before initial use, apply grease to the Adjustment Bolt. Also, apply grease periodically during use.
17. When reaching the maximum torque (15 ft-lb) by tightening the Adjustment Bolt, discontinue, and loosen the screw. Reposition and retry.
18. Support vehicle on jack stands before working on it.
19. Follow instructions and precautions in vehicle's service manual.
20. The warnings, precautions, and instructions discussed in this instruction manual cannot cover all possible conditions and situations that may occur. It must be understood by the operator that common sense and caution are factors which cannot be built into this product, but must be supplied by the operator.

Assembly

Read the ENTIRE IMPORTANT SAFETY INFORMATION section at the beginning of this document including all text under subheadings therein before set up or use of this product.

1. Insert the Adjustment Bolt (6) With the Hex end up, through the hole in the center of the Plain Axle (13).
2. Slide the Compression Spacer (20) onto the Adjustment Bolt (6) before continuing through the center hole on the Threaded Axle (10).
3. Secure Adjustment Bolt (6) with two Nuts (16).

Operation

Read the ENTIRE IMPORTANT SAFETY INFORMATION section at the beginning of this document including all text under subheadings therein before set up or use of this product.

WARNING! Remove MacPherson struts vehicle before attempting repairs. Put the struts in a MacPherson Strut Vise prior to using the Strut Spring Compressor.

Only use hand tools with the Strut Spring Compressor. Do not use any air, electric, or impact tools with this tool. Only operate this tool with a 3/4" socket and ratchet, 3/4" combination wrench, or other applicable hand tool. Power, air, or electric tools may compress the spring too rapidly, leading to injury.

1. Follow the vehicle service manual's instructions to remove the MacPherson Strut from the vehicle.
2. Position the strut into a strut vise.
3. Shut the vise and tighten.
4. Open the Spring Compressor up to 8". Do not open more than 8" or a long strut may slip off of the tool.
5. Make sure the hex nut on top of the Adjustment Bolt (6) is facing up.
6. Before clamping the spring, slip the Safety Ring (19) over the Hooks (5,7) as a safety precaution should the strut break loose. The Safety Ring (19) will keep the claws from springing open and causing injury.
7. Position the top hooks over the strut springs and tighten the Adjustment Bolt (6) so that the lower hooks will fit over the spring. See Figure A.

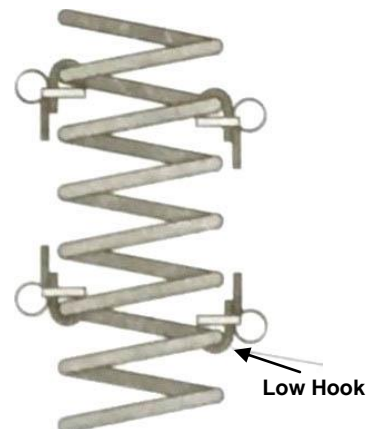

Figure A: Lower Hook

8. Make sure the same number of coils are between the hooks on each of the spring. Make sure the hooks are securely fastened and sit in line with the center axis of the spring. See Figure B.

9. Turn the **Adjustment Bolt (6)** clockwise to compress the strut spring. **ONLY COMPRESS THE SPRING ENOUGH TO REMOVE THE DRIVE NUT.**

WARNING! IF THE SPRING DOES NOT COMPRESS EVENLY, LOOSEN AND REPOSITION.

WARNING! DO NOT OVERTIGHTEN. Do not allow contact between Spring coils or between the arms of the Strut Spring Compressor.

10. Remove the strut rod nut, mounting plate and spring seat.

11. Carefully remove the spring with the strut spring compressor still attached.

12. Repair or replace the strut (See service manual).

13. Set the spring over the repaired or new strut and re-install the rod nut, mounting plate, and spring seat.

14. Loosen the strut spring compressor and remove it.

15. Remove the strut from the strut vise.

Maintenance

Read the **ENTIRE IMPORTANT SAFETY INFORMATION** section at the beginning of this document including all text under subheadings therein before set up or use of this product.

1. Grease the **Adjustment Bolt (6)** threads regularly.

2. An annual Strut Spring Compressor inspection is recommended. Only qualified service technicians should inspect this tool. If the tool is used extensively, more frequent inspections are recommended.

PLEASE READ THE FOLLOWING CAREFULLY THE MANUFACTURER AND/OR DISTRIBUTOR HAS PROVIDED THE PARTS LIST AND ASSEMBLY DIAGRAM IN THIS DOCUMENT AS A REFERENCE TOOL ONLY. NEITHER THE MANUFACTURER NOR DISTRIBUTOR MAKES ANY REPRESENTATION OR WARRANTY OF ANY KIND TO THE BUYER THAT HE OR SHE IS QUALIFIED TO MAKE ANY REPAIRS TO THE PRODUCT, OR THAT HE OR SHE IS QUALIFIED TO REPLACE ANY PARTS OF THE PRODUCT. IN FACT, THE MANUFACTURER AND/OR DISTRIBUTOR EXPRESSLY STATES THAT ALL REPAIRS AND PARTS REPLACEMENTS SHOULD BE UNDERTAKEN BY CERTIFIED AND LICENSED TECHNICIANS, AND NOT BY THE BUYER. THE BUYER ASSUMES ALL RISK AND LIABILITY ARISING OUT OF HIS OR HER REPAIRS TO THE ORIGINAL PRODUCT OR REPLACEMENT PARTS THERETO, OR ARISING OUT OF HIS OR HER INSTALLATION OF REPLACEMENT PARTS THERETO.

Note: Some parts are listed and shown for illustration purposes only, and are not available individually as replacement parts.

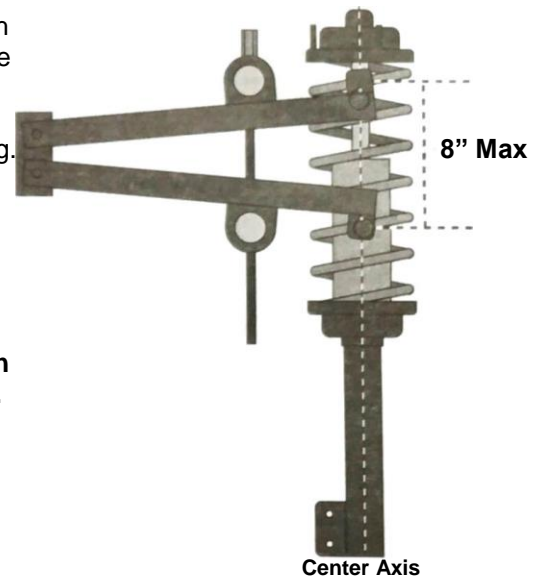

Figure B. Hook Location

Part	Description	Qty.	Part	Description	Qty.
1	Bolt	2	10	Threaded Axle	1
2	Nut	2	11	Hook	1
3	Retaining Ring	2	12	Spring	2
4	Hinge Axle	1	13	Plain Axle	1
5	Hook	1	16	Nut	2
6	Adjustment Bolt	1	17	Holding Pin	4
7	Hook	1	18	Pin Ring	4
8	Axle Pin	6	19	Safety Ring	1
9	Hook	1	20	Compression Spacer	1

