

Made in America

Lifetime Guarantee



H2 HUMMER LIGHT
Direct Factory
Replacement



**H2 Hummer DRL & Off-Road Lighting
Direct Factory Replacement**

HDRL001

*** Always disconnect the battery *before* attempting any electrical work on your vehicle.***



Intellitronix innovative dual-purpose lighting solution is a direct replacement for the factory H2 Hummer Daylight Running Lights. The high-power lights connect to the auxiliary switch and can be switched on when the H2 Hummer is in drive.

The H2 Hummer light uses a CREE XHP70.2 White LED that produces 4000 Lumens each. Two White Rebel LEDs replace the factory installed white light bulbs with an additional CREE XHP70.2 LED wired to the H2 Hummer high beams or auxiliary switch. When switched on they output an extra 8000 Lumens of super bright white light.

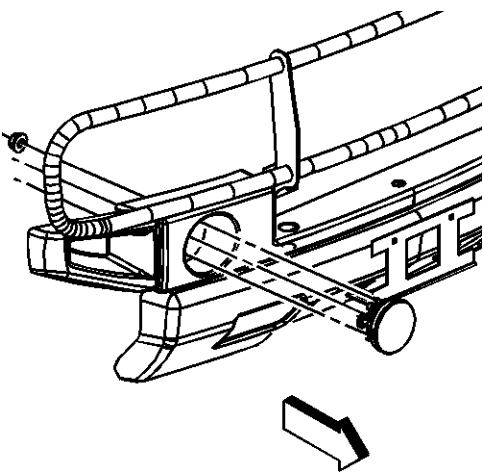

Removal

1. Disconnect the electrical connector.
2. Remove the nuts from the rear of the lamp assembly.
3. Disengage the clips retaining lamp.
4. Remove the lamp assembly.
5. Remove the bulb socket by turning the socket counterclockwise.
6. Remove the bulb.

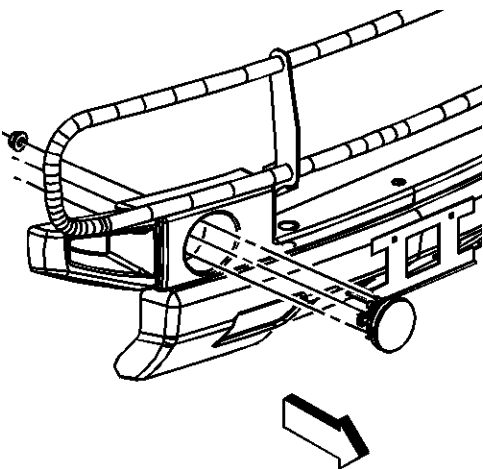

Installation

1. Install the Intellitronix Daytime Running Lights.
2. Install the Intellitronix Daytime Running Lights socket by turning the socket clockwise.
3. Install the lamp assembly.
4. Engage the clips retaining the lamp.
 - a. **Note:** Refer to Fastener Note
5. Install the nuts to the rear of the lamp assembly

Tighten the nuts to 6 [n-m] (53 lb. in).

6. Connect the electrical connector back to factory connector.
7. **White wire** - Run both wires into the cab to a switch that is wired to 12V Battery.
8. **Battery Red**--Connect the +12 Volt terminal to constant +12V power from the battery. Use 18 AWG wire to **Battery Red**--Connect the +12 Volt terminal to constant +12V power from the battery. Use 18 AWG wire to ensure the system receives a sufficient power feed

Made in America

Lifetime Guarantee



Technical Support

Monday – Friday

9am to 5 pm EST

(440) 359 7200

support@intellitronix.com

CHECK OUT THE **SUPPORT** PAGE AT

www.intellitronix.com

FOR QUICK ANSWERS (**Q&A**) TO YOUR QUESTIONS



This product carries a limited Lifetime Warranty.

This warranty is limited to replacement or repair of the unit at the discretion of Intellitronix.

RETURN POLICY PROCEDURES

Return Policy Instructions

1. Download the Intellitronix Return/Repair Form and fill in the information on the form about the product.
2. Place the product being returned in the original packaging that it came in and include a copy of the completed Intellitronix Return/Repair Form.
3. All packages must be accompanied with an RMA Number.

Please call Technical Support at +1 440-359-7200 to receive an RMA Number.

4. Mail the product being returned with the completed Return/Repair Form and a copy of the original sales invoice.

Request for Product Refund

1. All returns for a refund must have a completed Intellitronix Return/Repair Form included in the package with the returned product.
2. If the return is for a product that is not defective a 20% restocking fee will be charged. The product must be in the same pristine condition that it was sent to you.
3. Proof of purchase is required. Please include a copy of the original sales order with the returned product.
4. All product must be returned undamaged and in working order in the original packaging including plexiglass, sending units, mounting hardware, or you will be subject to additional charges for product and accessories not returned.
5. All refunds will be reviewed by the Accounting Office.